

DESIGN: Bins are molded with front, back and side grips for easy handling. Built-in rear hanger allows them to hang from louvered panels or rails while wide stacking ledge and anti-slide lock keep them steady and prevent forward shifting when stacked. Large molded front label slots for ID labels.

CONSTRUCTION: Injection molded.

COLOR:

- *Blue, Green, Ivory, Red, Yellow and Black- easily organize and color code your inventory. Manufactured with FDA approved materials.*
- *Clear- tri-clear bins increase content visibility.*

VERSATILITY: With a wide size offering, these bins adapt to every organizational needs.

STORAGE EFFICIENT: Optional accessories such as dividers, clear lids, windows and labels increases bin capacity, allows custom configurations and maximizes flexibility while keeping contents visible and organized at all times.

DURABLE: Made of high density polypropylene, bins are guaranteed not to break or crack under normal load conditions.

TEMPERATURE WITHSTAND: -32° to 250°F

CLEANABILITY: Easily cleaned with soap and water and impervious to most chemicals.



Highest Quality, Lowest Price Guaranteed!

QUANTUM FOOD SERVICE

15800 NW 15TH AVENUE, MIAMI, FLORIDA 33169 TOLL-FREE: (888) 993-3370 FAX: (954) 369-2512

E-MAIL: SALES@QUANTUMFOODSERVICE.COM WWW.QUANTUMFOODSERVICE.COM

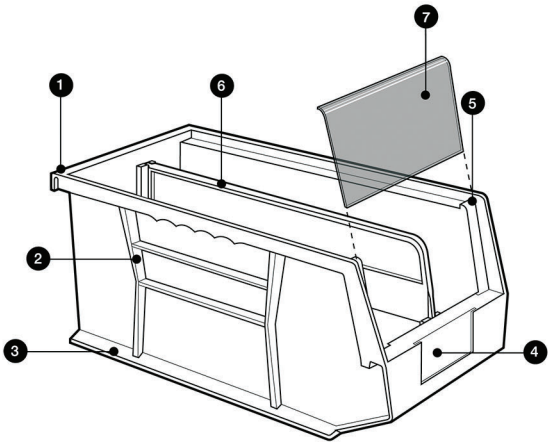

- ① Full width hanger supports bin when hanging from louvered panels or rails.
- ② Reinforced rib design adds strength and prevents spreading of side walls.
- ③ Extra-wide stacking ledge for secure stacking
- ④ Large front label slot allows larger bar code scanning and content identification.
- ⑤ Anti-slide stop prevents stacked bins from shifting forward
- ⑥ Optional dividers increase storage options
- ⑦ Optional windows maximize storage capacity, prevent spillage and protect parts from dust and dirt.



QUS230GN
with COV230



QUS270IV
with CRDUS270

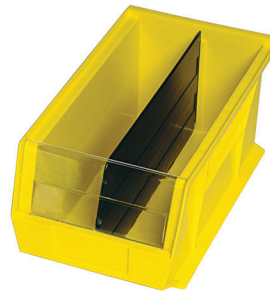

QUS240YL with
WUS239/240 and DUS240

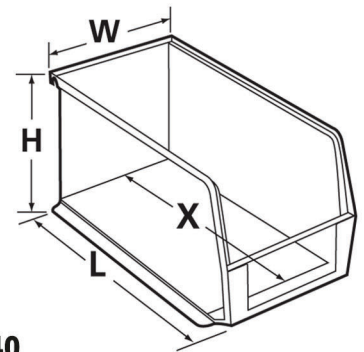

MODEL NO.	OUTSIDE DIMENSIONS L" x W" x H"	INSIDE DIMENSIONS L" x W" x H"	X"	CTN QTY	CTN WGT	BIN LOAD CAPACITY*	CLEAR WINDOW	CTN QTY	***DIVIDER & CROSS DIVIDER	CTN QTY	DIVIDER SLOTS	CLEAR LABEL HOLDER & INSERT	CLEAR LID	CTN QTY
QUS200	5" x 4-1/8" x 3"	4-3/8" x 3-7/16" x 2-13/16"	3-1/2"	24	5 lbs	13 lbs	-	-	DUS200	6	1	LTR-1300	-	-
QUS210	5-3/8" x 4-1/8" x 3"	4-3/4" x 3-7/16" x 2-13/16"	4"	24	6 lbs	15 lbs	-	-	DUS210	6	1	LTR-1300	COV210	24
QUS220	7-3/8" x 4-1/8" x 3"	6-3/4" x 3-7/16" x 2-13/16"	6"	24	8 lbs	15 lbs	-	-	DUS220	6	1	LTR-1300	COV220	24
QUS221	9-1/4" x 6" x 5"	8-1/2" x 5-1/8" x 4-1/2"	7-1/4"	12	6 lbs	25 lbs	WUS221	12	DUS221	6	1	LTR-1754	-	-
QUS224	10-7/8" x 4-1/8" x 4"	10-1/4" x 3-3/16" x 3-3/4"	9"	12	8 lbs	35 lbs	WUS224	12	DUS224	6	1	LTR-1253	COV224	12
QUS230	10-7/8" x 5-1/2" x 5"	10-1/4" x 4-3/8" x 4-3/4"	9"	12	10 lbs	35 lbs	WUS230/234	12	DUS230/235	6	1	LTR-1754	COV230	12
QUS232	5-3/8" x 11" x 3"	4-3/4" x 10-1/8" x 2-13/16"	4"	8	5 lbs	35 lbs	-	-	DUS210	6	3	LTR-1300	COV232	8
QUS234	14-3/4" x 5-1/2" x 5"	14-1/16" x 4-3/8" x 4-3/4"	12-13/16"	12	14 lbs	55 lbs	WUS230/234	12	DUS234	6	1	LTR-1754	-	-
QUS235	10-7/8" x 11" x 5"	10-1/4" x 10" x 4-3/4"	9"	6	10 lbs	55 lbs	WUS235	6	DUS230/235	6	3	LTR-1754	COV235	6
QUS236	7-3/8" x 11" x 3"	6-3/4" x 10-1/8" x 2-13/16"	6"	8	9 lbs	35 lbs	-	-	DUS220	6	3	LTR-1300	COV236	8
QUS238	18" x 5-1/2" x 5"	17-1/8" x 4-3/8" x 4-3/4"	15-7/8"	12	16 lbs	45 lbs	WUS230/234	12	DUS238 CRDUS238	6 6	1 3	LTR-1754	COV238	12
QUS239	10-3/4" x 8-1/4" x 7"	10" x 6-9/16" x 6-3/4"	8"	6	10 lbs	55 lbs	WUS239/240	6	DUS239	6	1	LTR-1754	COV239	6
QUS240	14-3/4" x 8-1/4" x 7"	14" x 6-9/16" x 6-3/4"	12"	12	24 lbs	65 lbs	WUS239/240	6	DUS240/250	6	1	LTR-1754	COV240	12
QUS241	13-5/8" x 8-1/4" x 6"	12-1/2" x 6-3/4" x 5-3/8"	11-1/8"	12	22 lbs	65 lbs	WUS241	12	DUS241	6	1	LTR-1754	-	-
QUS242	13-5/8" x 8-1/4" x 8"	12-1/2" x 6-3/4" x 7-3/8"	11-1/8"	12	25 lbs	65 lbs	WUS242	12	DUS242	6	1	LTR-1754	-	-
QUS245	10-7/8" x 16-1/2" x 5"	9-3/4" x 15" x 4-3/4"	9"	6	13 lbs	65 lbs	WUS245	6	DUS245	6	3	LTR-1754	-	-
QUS248	18" x 8-1/4" x 7"	17" x 6-1/2" x 6-1/2"	15-1/4"	6	19 lbs	80 lbs	WUS239/240	6	DUS248 CRDUS248	6 6	1 3	LTR-1754	COV248	6
QUS250	14-3/4" x 16-1/2" x 7"	14" x 14-3/4" x 6-3/4"	12"	6	21 lbs	80 lbs	WUS250	6	DUS240/250	6	3	LTR-1754	-	-
QUS255	16" x 11" x 8"	15-1/8" x 10" x 7-3/4"	11-5/8"	4	14 lbs	80 lbs	WUS255	4	DUS255	6	3	LTR-1754	-	-
QUS260	18" x 11" x 10"	17" x 9-1/2" x 9-3/4"	14-3/16"	4	17 lbs	80 lbs	WUS260	4	DUS260	6	3	LTR-1754	-	-
QUS265	18" x 8-1/4" x 9"	17-1/8" x 6-3/4" x 8-1/4"	14-1/2"	6	17 lbs	65 lbs	WUS265	6	DUS265	6	1	LTR-1754	-	-
QUS270	18" x 16-1/2" x 11"	17-1/8" x 14-3/4" x 10-1/4"	14"	3	16 lbs	80 lbs	WUS270	3	DUS270 CRDUS270	6	3	LTR-2400	-	-
QUS275MOB	18" x 16-1/2" x 11"***	17-1/8" x 14-3/4" x 10-1/4"	14"	3	25 lbs	-	WUS270	3	DUS270 CRDUS270	6	3	LTR-2400	-	-

*When attached to panels or rails **With casters, overall height is 14" ***For clear dividers add CL suffix to divider Model No. DUS200CL

Highest Quality, Lowest Price Guaranteed!

QUANTUM FOOD SERVICE

15800 NW 15TH AVENUE, MIAMI, FLORIDA 33169 TOLL-FREE: (888) 993-3370 FAX: (954) 369-2512

E-MAIL: SALES@QUANTUMFOODSERVICE.COM WWW.QUANTUMFOODSERVICE.COM