



# KGL SERIES

Gas Floor Mounted Stationary  
2/3 Jacketed Kettles



Model K40GL



## SPECIFIER STATEMENT

Gas self-contained, stainless steel fully insulated, 2/3 jacketed floor mounted steam kettle. Ellipsoidal bottom kettle liner formed and fully welded type 316 and type 304 stainless steel exterior with (3/4 x 5/8 inch 20 gallons) (3/8 x 1 inch 40 gallons and greater) heavy bar rim, embossed gallon/liter markings. 50 psi (3.4 kg/cm<sup>2</sup>) steam jacket rating. Spring assist hinged stainless steel cover with condensate ring and drop down lift handle with heavy duty pivot assembly that includes a yolk style mount with tie bar. Stainless steel splash proof enclosure for controls and faucet bracket. Controls include a power switch, power "on" light, solid state temperature control with graduated warm, simmer and boil setting, vacuum/pressure gauge, pressure relief valve, low water light and low water shut-off. Gas control with combination gas valve, flame failure and gas type is field convertible. High efficiency Power Burner Heating System (64% to 68% efficiency). Tubular stainless steel legs with removable section and flanged feet. Steam jacket permanently filled with treated, distilled water. 110-120V, 50-60 Hz, 5A, with 6 foot cord and three-prong grounding plug.

UL Certified to ANSI Z83.11/CSA 1.8. Certified to NSF Standard #4. Meets ASME.

**SPAN GAS TECHNOLOGY ENABLES FIELD ADJUSTABLE TO PROPANE GAS.**

Project \_\_\_\_\_  
AIA # \_\_\_\_\_ SIS # \_\_\_\_\_  
Item # \_\_\_\_\_ Quantity \_\_\_\_\_ C.S.I. Section 114000

## MODELS

- K20GL** — 100,000 BTU/hr 20 gal. true working capacity - **Discontinued**
- K40GL** 100,000 BTU/hr, 40 gal. true working capacity
- K60GL** 100,000 BTU/hr, 60 gal. true working capacity

## STANDARD FEATURES

- Gas self-contained, stainless steel, 2/3 jacketed floor mounted stationary steam kettle
- Ellipsoidal bottom kettle liner formed and fully welded standard type 316 and type 304 stainless steel exterior
- Heavy bar rim (3/4 x 5/8 inch 20 gallons) (3/8 x 1 inch 40 gallons and greater)
- Embossed gallon/liter markings
- Faucet bracket
- 50 psi (3.4 kg/cm<sup>2</sup>) steam jacket rating
- Spring assist hinged stainless steel cover with condensate ring and drop down lift handle with heavy duty pivot assembly that includes a yolk style mount with tie bar
- Two inch compression tangent draw-off valve with perforated strainer
- Tubular stainless steel legs with flanged feet
- Stainless steel enclosure for "water resistant" controls
- Controls include a power switch, power "on" light, solid state temperature control, vacuum/pressure gauge, pressure relief valve, low water light and low water shut-off
- Elevation from sea level to 8,999 feet standard, for higher elevation consult factory
- One year limited parts and labor warranty

## OPTIONS

- Two inch bolt on plug draw-off valve with perforated strainer
- Three inch bolt on compression tangent draw-off valve with perforated strainer increases height of kettle
- Correction facility package:
  - a. Security type fasteners with tack welds
  - b. Stainless steel cover over draw-off valve with chain
- Stainless steel protector for the draw-off valve with chain
- Heavy duty 14 gauge welded cover twin bar welded handles, NOT spring assist
- Second year extended limited parts and labor warranty

## ACCESSORIES (PACKAGED AND SOLD SEPARATELY)

- Clean-up kit, includes draw-off brush, clean-up brush and paddle scrapper with 40" handle
- Stainless steel 48" whip
- Non-perforated strainer for draw-off valve
- (12") (18" double jointed) single pantry lead-free faucet
- (12") (18" double jointed) double pantry lead-free faucet
- Double pantry washdown hose with 16" add-on lead-free faucet with vacuum breaker
- Double pantry washdown hose lead-free with vacuum breaker
- Double pantry pot filler lead-free with vacuum breaker

**KGL SERIES – Gas Floor Mounted Stationary 2/3 Jacketed Kettles**

Approved by \_\_\_\_\_ Date \_\_\_\_\_ Approved by \_\_\_\_\_ Date \_\_\_\_\_

### SERVICE CONNECTIONS

**Electrical Connection:** 110-120V, 50-60 Hz, 5A, with 6 foot cord and three-prong grounding plug.

**Gas Connection:** 3/4" NPT supply line required.

**Water Connection:** For faucet option only.

Embossed Gallon/Liter Markings		
20-Gallon*	40-Gallon	60-Gallon
20 - 76	40 - 151	60 - 227
18 - 68	35 - 132	55 - 209
16 - 61	30 - 114	50 - 189
14 - 53	25 - 95	45 - 171
12 - 46	20 - 76	40 - 151
10 - 38	15 - 57	35 - 132
		25 - 95
		20 - 76

### INSTALLATION MANUAL

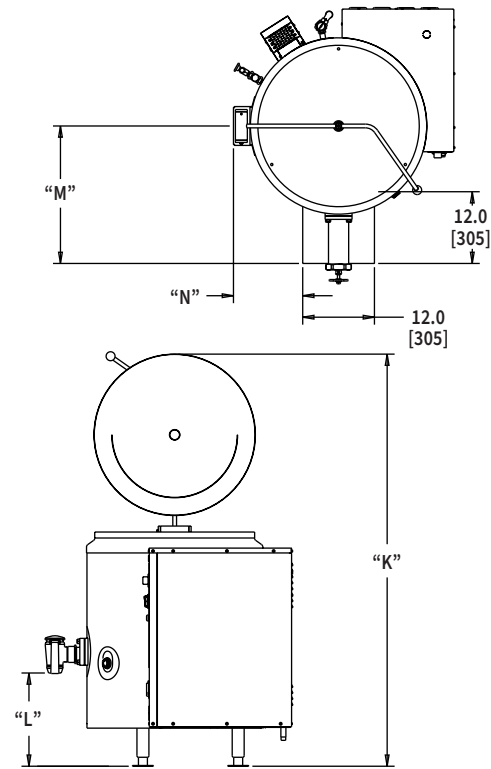
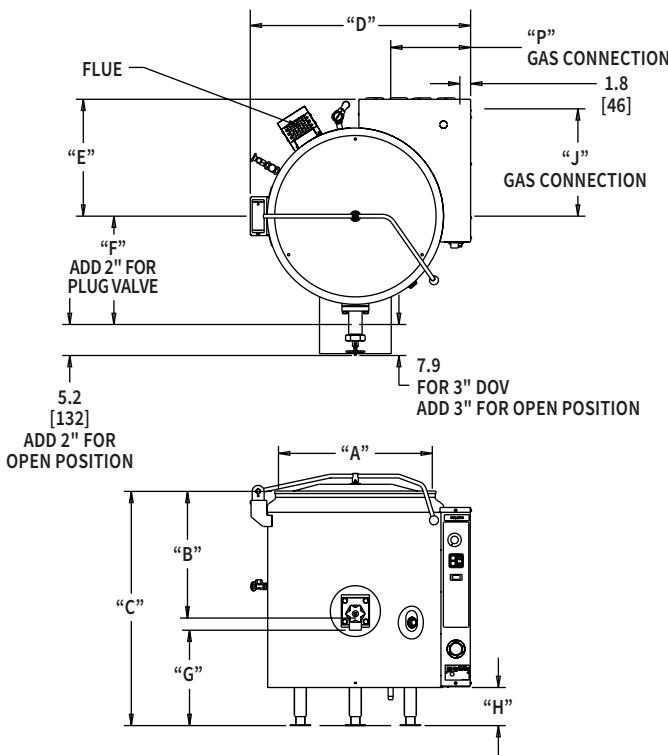

### TRUE WORKING CAPACITIES (IN 4 OZ. SERVINGS)

80 quarts/20 gallons/76 liters/640 servings  
 120 quarts/40 gallons/152 liters/1,280 servings  
 160 quarts/60 gallons/228 liters/1,920 servings

### NOTES

- Dimensions which locate the above connections have a tolerance of + or -3" (+ or -75mm). Normal dimensions are in inches. Dimensions in [ ] are in millimeters.
- Installation of backflow preventers, vacuum breakers and other specific code requirements is the responsibility of the owner and installer. It is the responsibility of the owner and installer to comply with local codes.
- Do not use plastic drains.
- Do not connect this unit to a ground-fault circuit-interrupter (GFCI) 125-volt, single-phase, 15- and 20-ampere receptacle. Electronic burner ignition systems are prone to nuisance tripping and possible ignition failure.
- This appliance is manufactured for commercial installation only and is not intended for home use.

CAD and/or Revit Files Available

Model	True Working Capacity	A	B	C	D	E	F	G	H	J	K	L	M	N	P
K20GL*	20 gallons	21.6	15.2	36.8	32.7	18.6	15.6	19.5	6.4	17	32.6	19.2	20.9	9.5	14.6
	76 liters	549	386	935	831	472	396	495	163	432	828	488	531	241	371
K40GL	40 gallons	26	21.2	39.2	36.7	19.8	17.75	16	6.4	18	69	15.6	23	11.6	14.1
	152 liters	660	538	996	932	503	451	406	163	457	1753	396	584	295	358
K60GL	60 gallons	29.5	24.2	39.5	40.9	21.7	19.75	16.6	6	19.9	76.6	16.2	26.5	13.8	13.7
	227 liters	749	615	1003	1039	551	502	422	152	505	1946	411	673	351	348

\* Discontinued

As continued product improvement is a policy of Vulcan, specifications are subject to change without notice.