

# "PTS2" PASS-THROUGH SHELVES

## *Double Tier, 16GA*

**FEATURES:**

- Includes Lower Pass Through Shelf And Overshelf
- 16GA Stainless Steel Hat Channel Allows Shelf To Be Freely Positioned In Field
- Includes Wall Mount Brackets To Securely Fasten Shelf To Wall
- Furnished With Stallion Edge Turned Down 1-1/2" 90 Degrees And 1/2" Back 45 Degrees Along Front And Rear
- Ends Are Square Turned Down 1-1/2" At Wall
- Overshelf Is Secured To Lower Shelf With 1" Stainless Steel Tubing

**SPECIFICATIONS:**

- All TIG Welded, Exposed Welds Are Polished To Match Adjacent Surface
- 16GA Type 300 Stainless Steel

**CERTIFICATIONS:**



PTS26K-2460

## "PTS2" DOUBLE PASS-THROUGH SHELVES

LENGTH	12" WIDTH	A	WT (LBS)	18" WIDTH	A	WT (LBS)	24" WIDTH	A	WT (LBS)
24"	PTS26K-1224	4-3/4"	36	PTS26K-1824	10"	41	PTS26K-2424	7-1/2"	46
36"	PTS26K-1236	4-3/4"	49	PTS26K-1836	10"	56	PTS26K-2436	7-1/2"	64
48"	PTS26K-1248	4-3/4"	62	PTS26K-1848	10"	72	PTS26K-2448	7-1/2"	82
60"	PTS26K-1260	4-3/4"	75	PTS26K-1860	10"	87	PTS26K-2460	7-1/2"	100
72"	PTS26K-1272	4-3/4"	88	PTS26K-1872	10"	102	PTS26K-2472	7-1/2"	118
84"	PTS26K-1284	4-3/4"	106	PTS26K-1884	10"	123	PTS26K-2484	7-1/2"	141
96"	PTS26K-1296	4-3/4"	119	PTS26K-1896	10"	139	PTS26K-2496	7-1/2"	159
108"	PTS26K-12108	4-3/4"	132	PTS26K-18108	10"	154	PTS26K-24108	7-1/2"	176
120"	PTS26K-12120	4-3/4"	145	PTS26K-18120	10"	169	PTS26K-24120	7-1/2"	193
132"	PTS26K-12132	4-3/4"	158	PTS26K-18132	10"	185	PTS26K-24132	7-1/2"	211
144"	PTS26K-12144	4-3/4"	171	PTS26K-18144	10"	201	PTS26K-24144	7-1/2"	229

ALL DIMENSIONS ARE TYPICAL. TOLERANCE +/- .500". JOHN BOOS & CO. RESERVES THE RIGHT TO CHANGE SPECIFICATIONS WITHOUT NOTICE.

# DETAILED SPECIFICATIONS

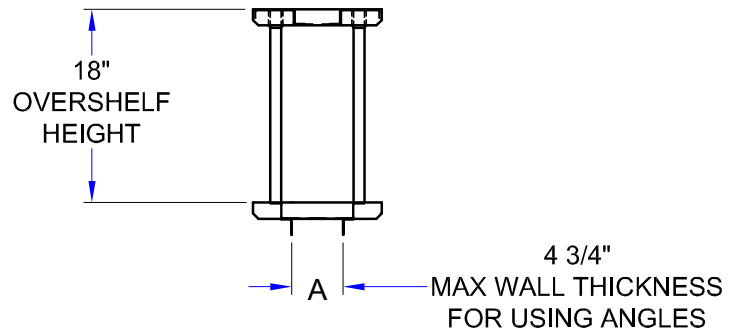
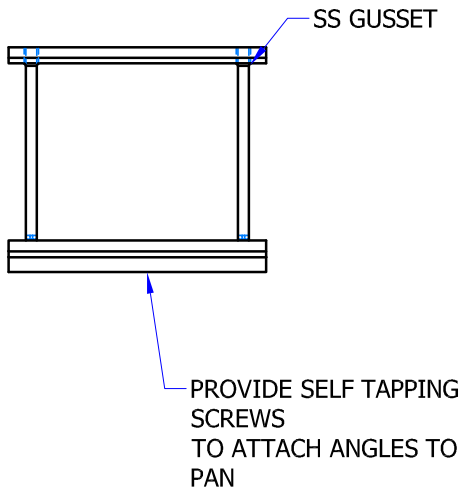
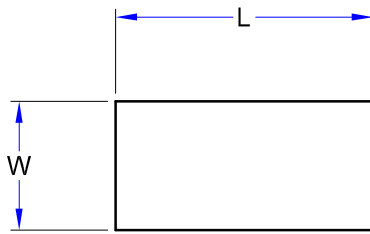

## "PTS2" DOUBLE PASS-THROUGH SHELVES

LENGTH	12" WIDTH	A	WT (LBS)	18" WIDTH	A	WT (LBS)	24" WIDTH	A	WT (LBS)
24"	PTS26K-1224	4-3/4"	36	PTS26K-1824	10"	41	PTS26K-2424	7-1/2"	46
36"	PTS26K-1236	4-3/4"	49	PTS26K-1836	10"	56	PTS26K-2436	7-1/2"	64
48"	PTS26K-1248	4-3/4"	62	PTS26K-1848	10"	72	PTS26K-2448	7-1/2"	82
60"	PTS26K-1260	4-3/4"	75	PTS26K-1860	10"	87	PTS26K-2460	7-1/2"	100
72"	PTS26K-1272	4-3/4"	88	PTS26K-1872	10"	102	PTS26K-2472	7-1/2"	118
84"	PTS26K-1284	4-3/4"	106	PTS26K-1884	10"	123	PTS26K-2484	7-1/2"	141
96"	PTS26K-1296	4-3/4"	119	PTS26K-1896	10"	139	PTS26K-2496	7-1/2"	159
108"	PTS26K-12108	4-3/4"	132	PTS26K-18108	10"	154	PTS26K-24108	7-1/2"	176
120"	PTS26K-12120	4-3/4"	145	PTS26K-18120	10"	169	PTS26K-24120	7-1/2"	193
132"	PTS26K-12132	4-3/4"	158	PTS26K-18132	10"	185	PTS26K-24132	7-1/2"	211
144"	PTS26K-12144	4-3/4"	171	PTS26K-18144	10"	201	PTS26K-24144	7-1/2"	229

ALL DIMENSIONS ARE TYPICAL. TOLERANCE +/- .500". JOHN BOOS & CO. RESERVES THE RIGHT TO CHANGE SPECIFICATIONS WITHOUT NOTICE.