

VICTORY[®]

ULTRASPEC

PROJECT: _____

ITEM # _____ QTY: _____

MODEL # _____

AIA # _____ SIS # _____

DUAL TEMP REACH-IN WINE REFRIGERATOR

WCDDT-2D-S1-HC



EXCLUSIVE WARRANTY

- ▶ 7 Year Parts, Labor and Compressor
- ▶ Exclusive 2 Year Warranty On Magnetic Door Gaskets
- ▶ Lifetime Warranty On Handles & Hinges (parts only)

CABINET CONSTRUCTION

- Stainless Steel Exterior And Interior
- Stay-Open Door Feature For Easy Product Loading
- Ultra Glass Doors
- Magnetic Door Switch Automatically Activates Interior LED Light
- Heavy-Duty Cylinder Locks
- One Piece, Snap-In Magnetic Door Gaskets
- Low Profile Vertical Door Handles
- Hinged Front Shroud
- Energy Saving Thermal Breaker
- Stainless Steel Breaker Caps
- Dual Temp Refrigerator Unit Provide Two Different Operating Temperature Zones For Different Types Of Products
- 14 Fully Extractable Wine Drawers, 2 Fixed Wine Racks
- 80 Bottle Capacity Per Door Section
- 6" High Adjustable Stainless Steel Legs
- 8' Cord And Plug (see electrical data for details)

FEATURES

- Full Electronic Control With Touchpoint Interface
- Separate Controllers for each Temperature Zone
- Expansion Valve Technology
- Manager's Lockout Feature
- Anti-Condensate Door Perimeter Heaters
- Variable Speed Compressor Technology

REFRIGERATION

- Refrigeration System Uses R-290 Refrigerant To Comply With All Environmental Concerns
- Adaptive Defrost For Reduced Energy Consumption And More Consistent Product Temperatures
- Each Section Capable Of Maintaining Product Temperature 40°F To 60°F



Please Verify Qualifying Units By Visiting:
www.energystar.gov/cfs

OPTIONS & ACCESSORIES

- Stainless Steel Case Back
- Door Swing Orientation (at time of order)
- 3", 6" Casters Or 6" Seismic Legs
- Remote Models* (6" legs only) (refrigerant must be specified at time of order, see note)

3779 Champion Blvd, Winston-Salem, NC 27105

ph: (888) 845-9800 | fax: (800) 253-5168

Sales@VictoryRefrigeration.com | VictoryRefrigeration.com

Rev. 7/1/24 Printed in U.S.A.

APPROVAL: _____ DATE: _____

DUAL TEMP REACH-IN WINE REFRIGERATOR

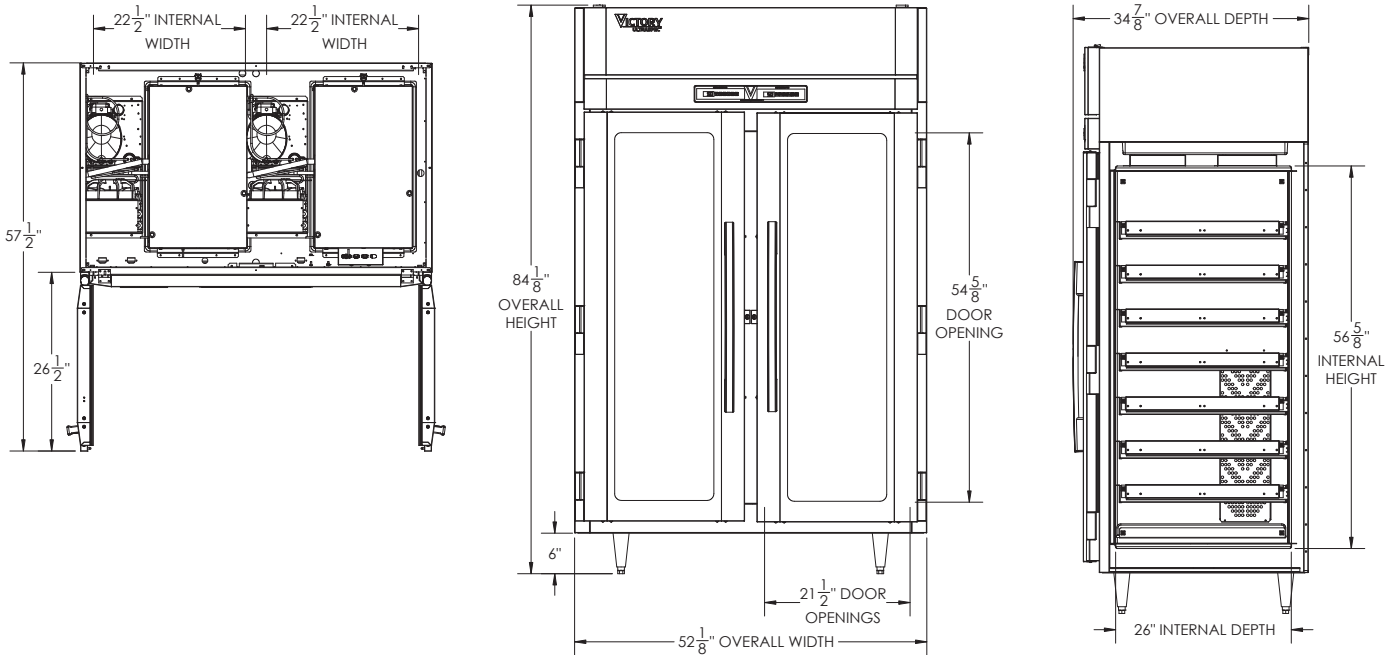

We reserve the right to change specifications and product design without notice. Such revisions do not entitle the buyer to corresponding changes, improvements, additions or replacements for previously purchased equipment. Dimensional tolerances +/- 1/4". Metric dimensions (MM)

12" Top clearance is required

CHARACTERISTICS		ELECTRICAL DATA		SHIPPING DETAILS	
Net Capacity (cubic ft.)	(2) 21.5	Cabinet Voltage**	(2) 115/60/1	Height	88"
Width, Overall (in.)	52 1/8"	Total Amperes	(2) 6.5	Width	60"
Depth, Overall (with handle)	34 7/8"	NEMA Plug (8' cord)	(2) 5-15P	Depth	45"
Height Overall (6" legs)	84 1/8"	REFRIGERATION DATA		Crated Weight	918 lbs
Depth, Door Open 90°	57 1/2"	Condensing Unit Size, HP	(2) 1/3	*NOTE: Remote unit are field wired and comes with 6" legs. Refrigerant must be specified at time of order.	
Door Openings (in.)	21 1/2" x 54 5/8"	Refrigerant	R-290		
No. Of Doors/Shelves/Racks	2/14/2	Capacity (BTU/HR) (100°F/20°F)	2800		
		Heat Rejection (BTU/HR)	4200		
		Charge (lbs/grams/ounces)	(2) 0.165 / 75 / 2.64		

** NOTE: This unit utilizes variable speed compressor technology. The compressor can experience nuisance tripping on Class A GFCI outlets which have a trip limit of 4 mA to 6 mA. To avoid this issue in a location that requires GFCI circuit protection, Victory recommends using a HUBBELL Model Number GFRST83W 20A Heavy Duty Hospital Grade Self-Test GFCI Receptacle.

3779 Champion Blvd, Winston-Salem, NC 27105 | ph: (888) 845-9800 | fax: (800) 253-5168

Sales@VictoryRefrigeration.com | VictoryRefrigeration.com

Rev. 7/1/24 Printed in U.S.A.