

# Cold Pan Units

## ASSEMBLY INSTRUCTIONS

### CAUTION

INSPECT CONTENTS IMMEDIATELY AND FILE CLAIM WITH DELIVERING CARRIER FOR ANY DAMAGE.  
**SAVE YOUR BOX AND ALL PACKING MATERIALS.**  
 YOU ARE RESPONSIBLE FOR DAMAGE TO YOUR UNIT IF RETURNED IMPROPERLY PACKED.

### MAINTENANCE FOR ICED COLD PANS

Proper cleaning of the unit is required. When rubbing or scouring, always move gently in the direction of the polish lines (grains). A Scotch-Brite™ general purpose pad may be used. DO NOT USE STEEL WOOL.

#### CAUTION:

1. This equipment is designed and sold for commercial use only by personnel trained and experienced in its operation and is not sold for consumer use in and around the home nor for use directly by the general public in foodservice locations.
2. Do not immerse unit in water.
3. All repairs should be done by an authorized service center.

#### To assemble Unit with Adjustable Undershef:

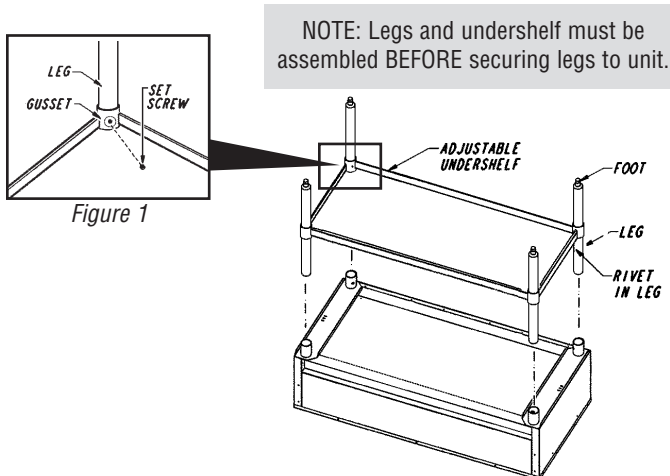

NOTE: Legs and undershef must be assembled BEFORE securing legs to unit.

1. Place unit upside-down with gussets facing up.  
**Caution:** Use cardboard or other material to prevent scratching top.
2. Install legs into gussets. Make sure rivet in leg is closer to gusset than to the foot end.
3. Align undershef gussets with legs, and slide undershef down legs to desired position. Do not force or beat corners as damage could occur.
4. Tighten set screws in undershef gussets to secure undershef (see *Figure 1*) and install feet into legs, using a rubber mallet.
5. Tighten set screws in gussets to secure legs to table.
6. Place unit on its back.
7. See applicable cutting board mounting instructions on back page.

#### To assemble Unit with Bolted Undershef (optional):

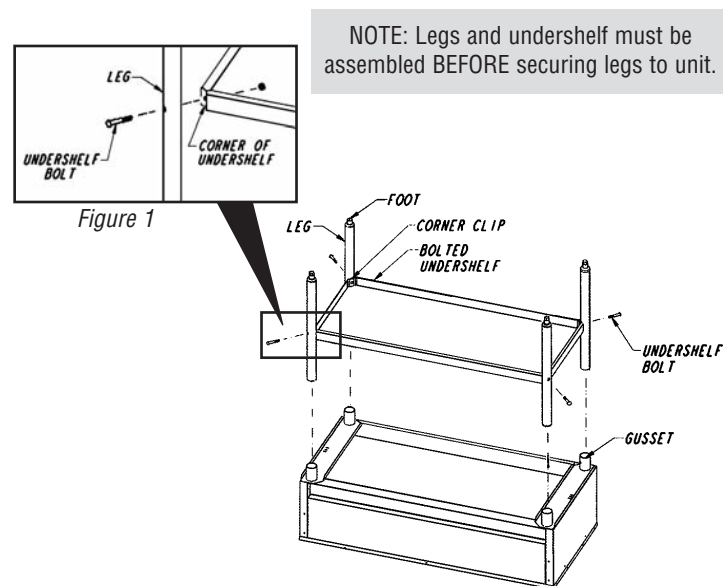

NOTE: Legs and undershef must be assembled BEFORE securing legs to unit.

1. Place unit upside-down with gussets facing up.  
**Caution:** Use cardboard or other material to prevent scratching top.
2. Install legs into gussets.
3. Mount undershef to legs by inserting bolt thru hole in leg and thru hole in corner of undershef, and tighten with hex nut (see *Figure 1*).
4. Tighten set screws in gussets to secure legs.
5. Place unit on its back.
6. See applicable cutting board mounting instructions on back page.

(continued on back page) →

EG10004 Revised 10/09



• 100 Industrial Boulevard, Clayton, Delaware 19938-8903 U.S.A. • www.eaglegrp.com  
 • Phone: 302/653-3000 • (Foodservice/SpecFAB®) 800/441-8440 • (MHC/Retail) 800/637-5100  
 • Fax: 302/653-2065 or 302/653-3036

Eagle Foodservice Equipment, Eagle MHC, SpecFAB®, and Retail Display are divisions of Eagle Group. ©2009 by the Eagle Group

# Cold Pan Units

## ASSEMBLY INSTRUCTIONS

### Cutting Board with Drop Brackets (for portable units)

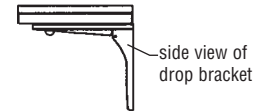
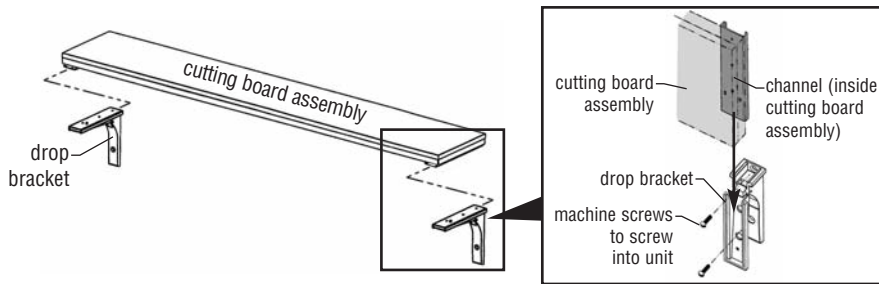

1. Mount drop brackets to unit, using machine screws and threaded fasteners on table.
2. Mount cutting board assembly to drop brackets on unit.
3. Raise cutting board up until it is in horizontal position, and slide toward unit.

### Cutting Board with Stationary Brackets (for stationary units)

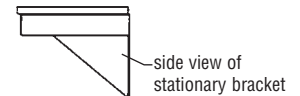
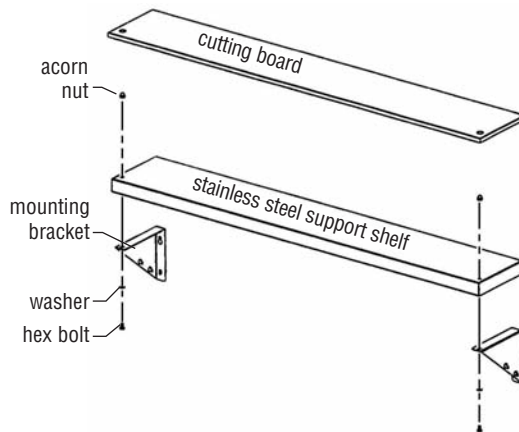

1. Attach mounting brackets to support shelf, using acorn nuts, washers, bolts and predrilled holes. Note: acorn nuts must be at the top.
2. Install machine screws into threaded fasteners on unit. Do not tighten.
3. Align keyholes in mounting brackets with screws and mount support shelf/bracket assembly to unit. Tighten screws.
4. Align holes in cutting board with acorn nuts, and place cutting board onto support shelf.

### Cutting Board with Optional Plate Shelf

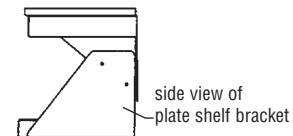
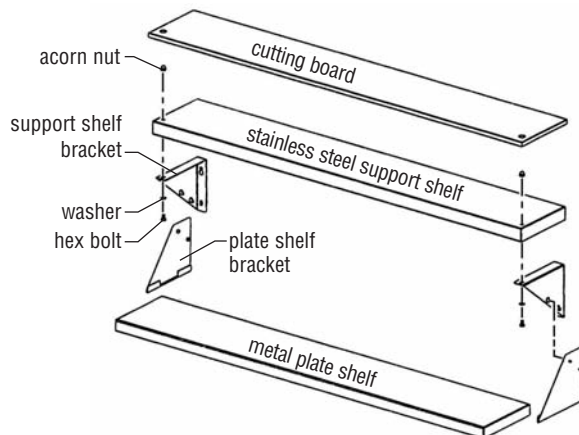

1. Attach support shelf brackets to support shelf, using acorn nuts, washers, bolts and predrilled holes. Note: acorn nuts must be at the top.
2. Install machine screws into threaded fasteners on unit. Do not tighten.
3. Align keyholes in mounting brackets with screws and mount support shelf/bracket assembly to unit. Tighten screws.
4. Hook metal plate shelf into bottom flange of plate shelf brackets.
5. Using keyholes on support shelf brackets, mount plate shelf/bracket assembly onto support shelf/bracket assembly.
6. Align holes in cutting board with acorn nuts, and place cutting board onto support shelf.

(End)