

ASSEMBLY INSTRUCTIONS

CAUTION

INSPECT CONTENTS IMMEDIATELY AND FILE CLAIM WITH DELIVERING CARRIER FOR ANY DAMAGE. **SAVE YOUR BOX AND ALL PACKING MATERIALS.** YOU ARE RESPONSIBLE FOR DAMAGE TO YOUR UNIT IF RETURNED IMPROPERLY PACKED.

Thank you for your purchase. Before assembly, read this instruction manual carefully. After reading, be sure to store this instruction in a safe place, should it be needed for future reference.

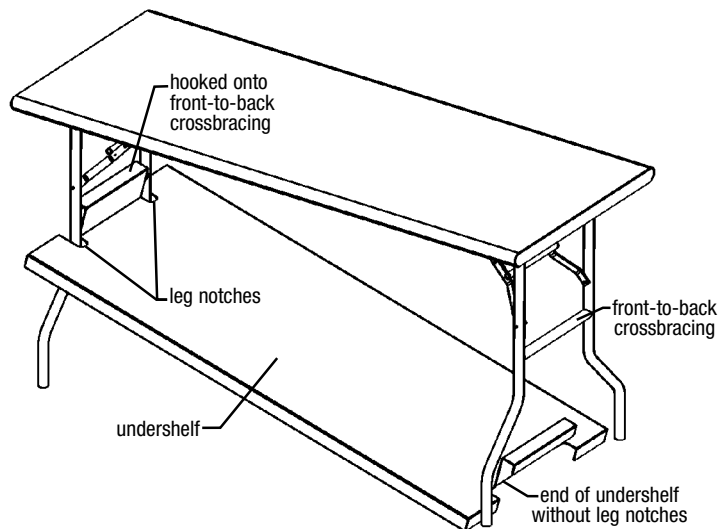

figure 1

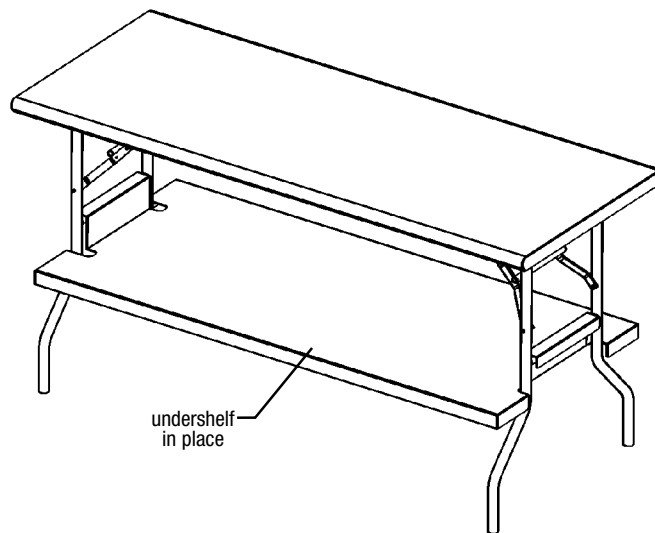

figure 2

1) Legs

- Carefully turn the table upside-down onto its tabletop.
- Pull legs so that they are fully extended.
- Push the hinged brace down until it locks in place. This will stabilize the legs and insure that the table will not fold.
- Return the table onto its feet.

2) Optional Undershelf

- Place the undershelf underneath the table, taking note of which end of the undershelf the leg notches are located.
- Raise the end with leg notches upward and hook onto front-to-back crossbracing, as shown in *figure 1*.
- Repeat on remaining end of table, as shown in *figure 2*. Undershelf is now in place.

Removal of Optional Undershelf

- Unhook the end without leg notches and lower, as seen in *figure 1*.
- Unhook the end with leg notches.
- Remove undershelf from under the table.

(End)