

Sandwich Prep Station

ASSEMBLY INSTRUCTIONS

CAUTION

INSPECT CONTENTS IMMEDIATELY AND FILE CLAIM WITH DELIVERING CARRIER FOR ANY DAMAGE. **SAVE YOUR BOX AND ALL PACKING MATERIALS.** YOU ARE RESPONSIBLE FOR DAMAGE TO YOUR UNIT IF RETURNED IMPROPERLY PACKED.

Step 1 - Assemble bottom frame supports to 18" posts.

Snap split sleeves onto posts at desired height.

- The wider part of the taper goes toward the bottom.
- Make sure rib on split sleeve is seated into a groove on the post.

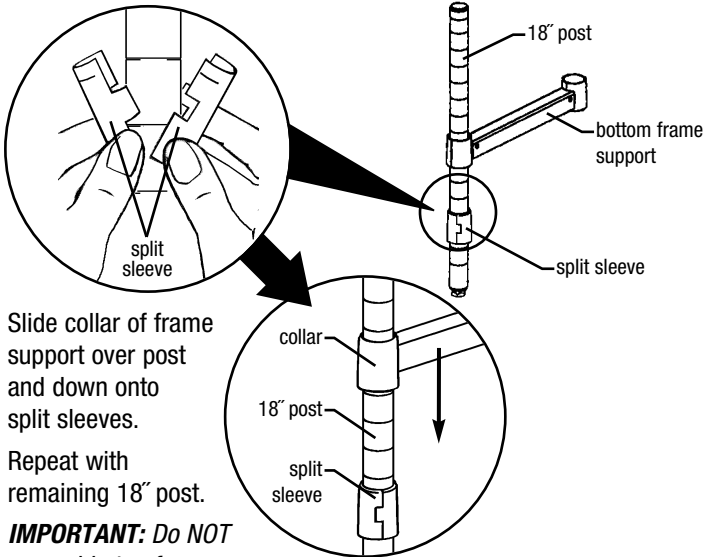

Slide collar of frame support over post and down onto split sleeves.

Repeat with remaining 18" post.

IMPORTANT: Do NOT assemble top frame supports to posts yet.

Step 2 - Attach assemblies to two of the four 74" posts.

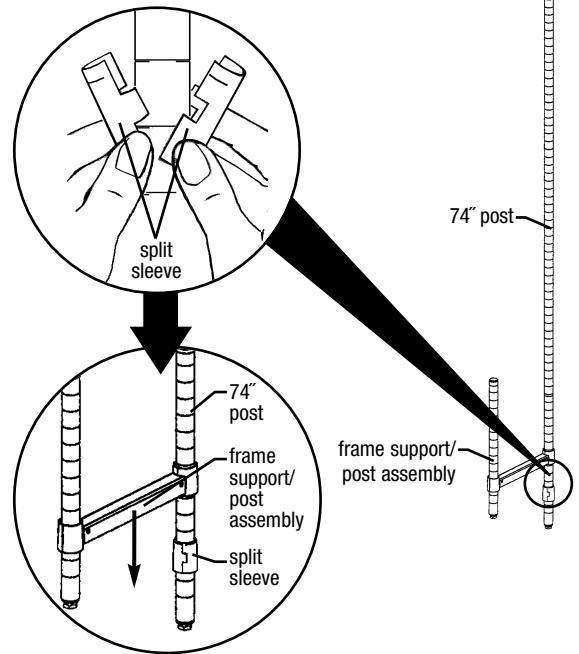

Step 3 - Attach 3-sided channel frame to 74" posts.

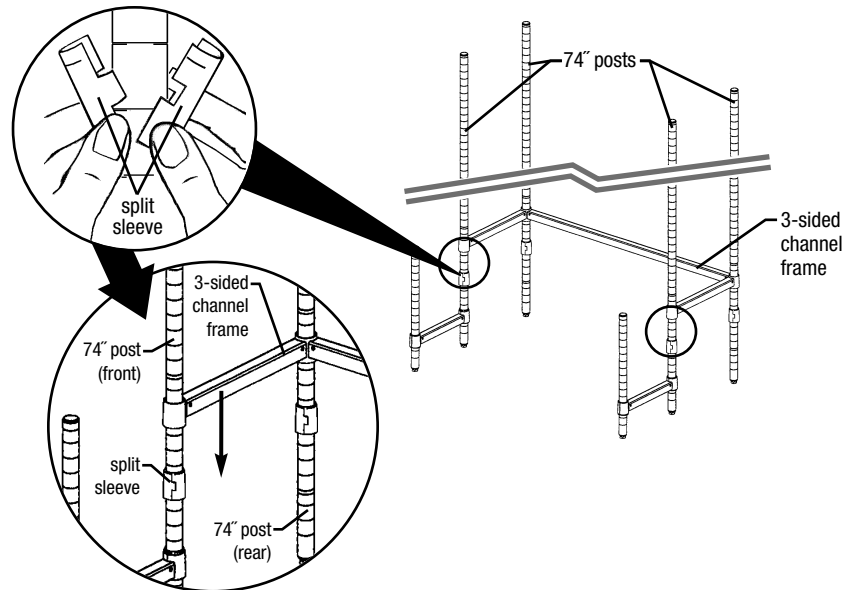

(continued on page 2)

Sandwich Prep Station

ASSEMBLY INSTRUCTIONS

Step 4 - Attach top frame supports.

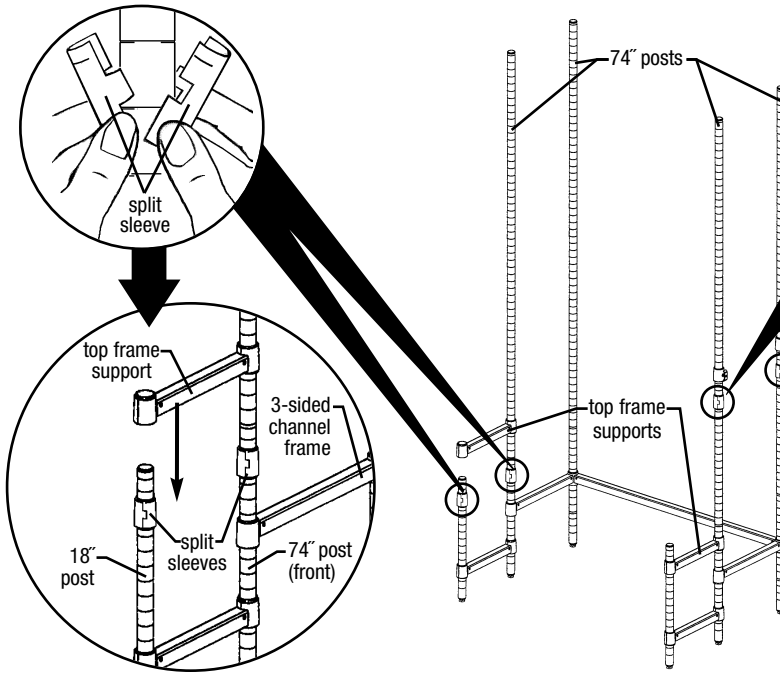

Step 5 - Attach bottom grid panel clamps onto post groove #34.

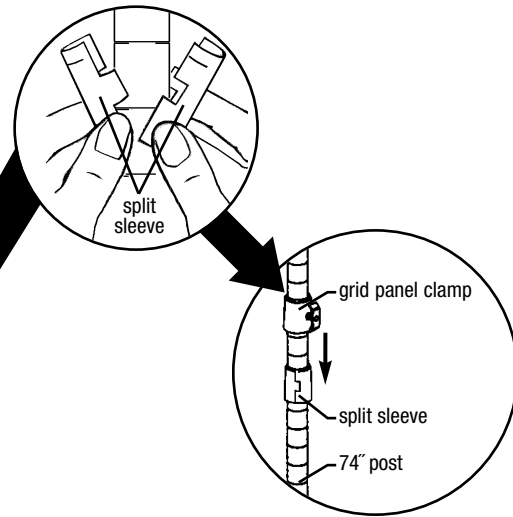

Step 6 - Attach bottommost shelf onto post groove #42.

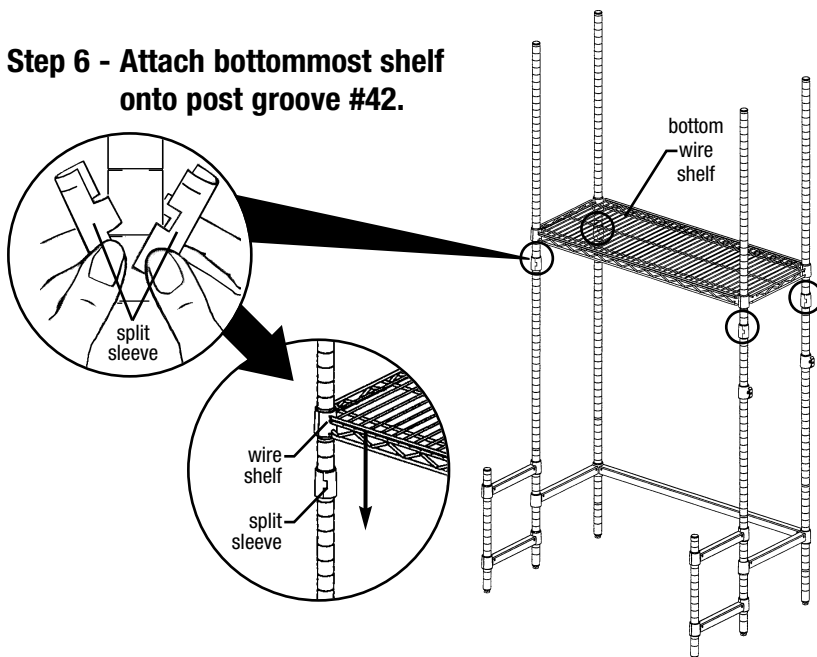

Step 7 - Repeat Step 6 to install next shelf onto post groove #54.

(continued on page 3)

Sandwich Prep Station

ASSEMBLY INSTRUCTIONS

Step 8 - Repeat Step 5 to attach top grid panel clamps onto post groove #64.

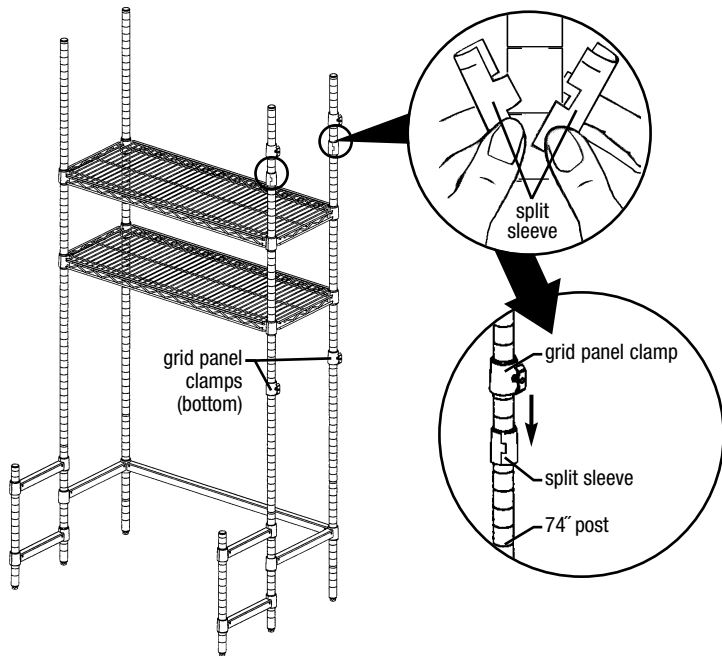

Step 9 - Repeat Step 6 to install remaining wire shelf onto post groove #66.

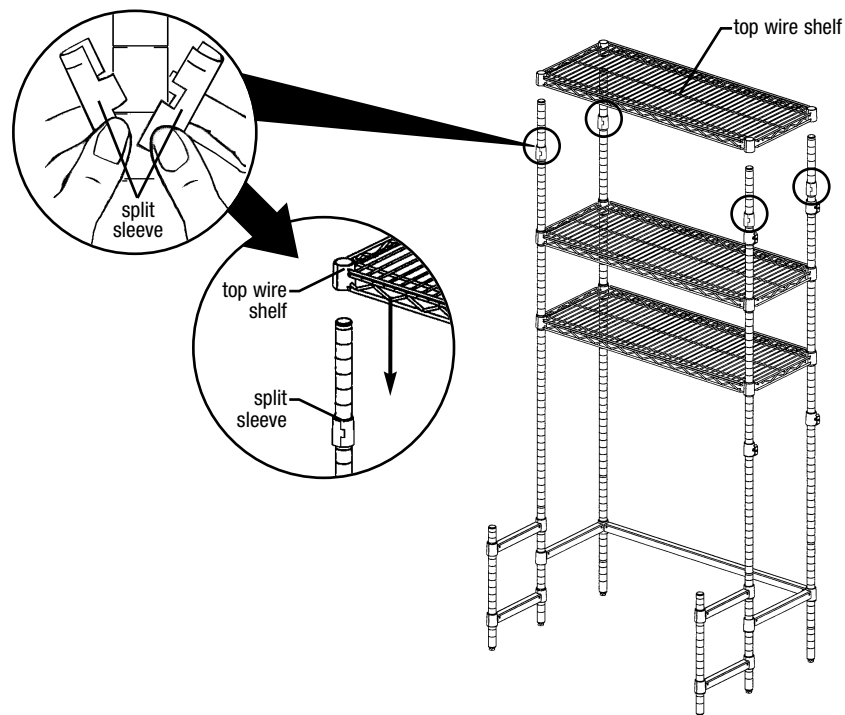

(continued on back page) 

Sandwich Prep Station

ASSEMBLY INSTRUCTIONS

Step 10 - Attach wall mat to grid panel clamps.

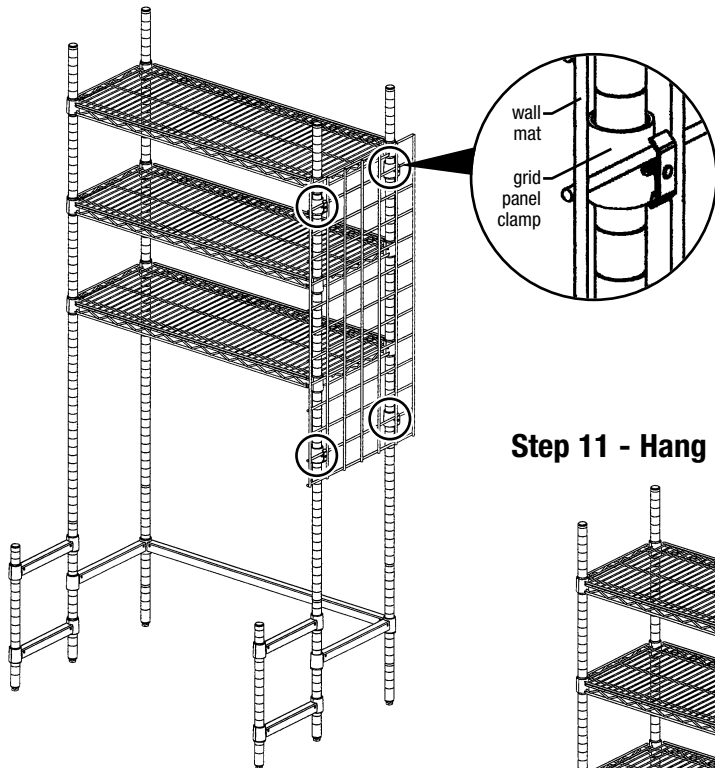

Step 11 - Hang wire basket and snap plastic bin holder onto wall mat.

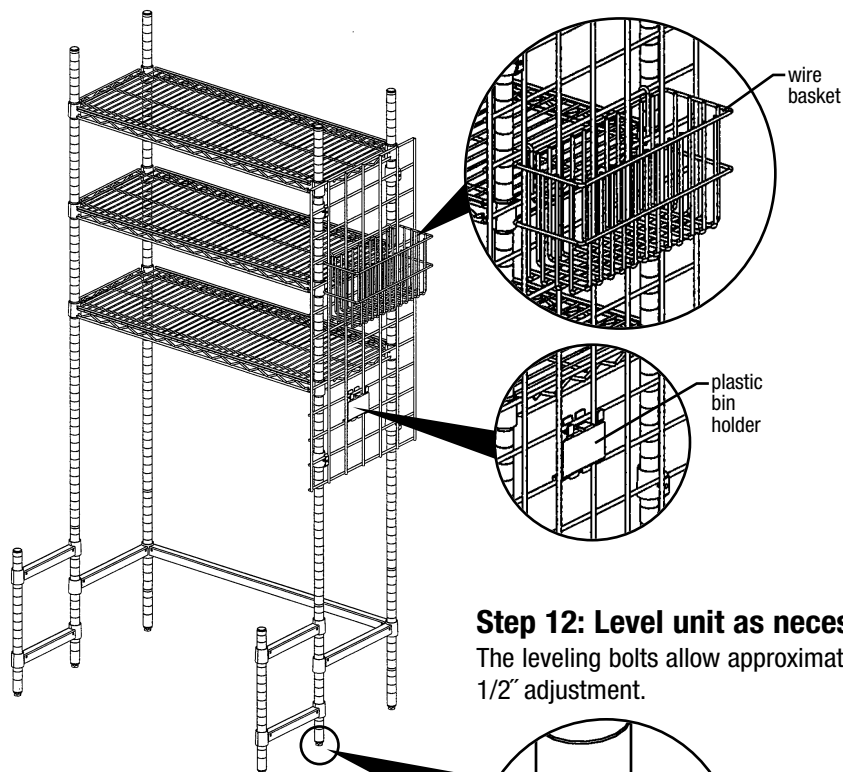

Step 12: Level unit as necessary.

The leveling bolts allow approximately 1/2" adjustment.

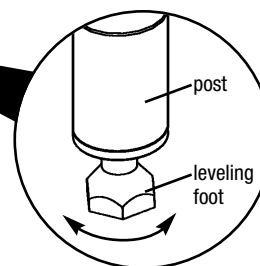

(End) Assembly is complete.