

PART #361835

RedHots® Display Light Units

OPERATING MANUAL AND INSTRUCTIONS

CAUTION

INSPECT CONTENTS IMMEDIATELY AND FILE CLAIM WITH DELIVERING CARRIER FOR ANY DAMAGE. **SAVE YOUR BOX AND ALL PACKING MATERIALS.** YOU ARE RESPONSIBLE FOR DAMAGE TO YOUR UNIT IF RETURNED IMPROPERLY PACKED.

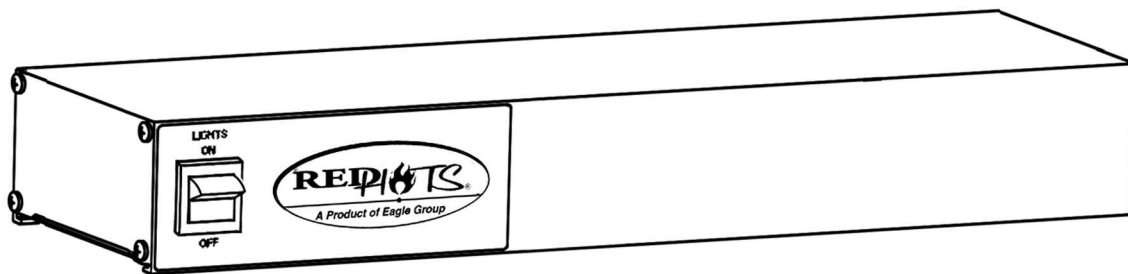

IMPORTANT!

This manual provides installation and operation instructions for Eagle's RedHots® Display Light Units. Please read this manual before installing and operating this unit. Personal injury or damage to the unit can occur if installed or operated incorrectly.

Retain this manual for future reference.

CAUTION

1. This equipment is designed and sold for commercial use only by personnel trained and experienced in its operation and is not sold for consumer use in and around the home, nor for use directly by the general public in foodservice locations.
2. Do not immerse unit in water.
3. All repairs should be done by an authorized service center.
4. Units should be turned off when not in use. It is recommended that unit be disconnected from power supply by removing plug receptacle, or by shutting off power supply to the unit.

EG10074 Revised 06/07



• 100 Industrial Boulevard, Clayton, Delaware 19938-8903 U.S.A. • www.eaglegrp.com
• Phone: 302/653-3000 • (Foodservice/SpecFAB) 800/441-8440 • (MHC/Retail) 800/637-5100
• Fax: 302/653-2065

Eagle Foodservice Equipment, Eagle MHC, SpecFAB, and Retail Display are divisions of Eagle Group. ©2007 by the Eagle Group

RedHots® Display Light Units

OPERATING MANUAL AND INSTRUCTIONS

GENERAL NOTES:

Eagle's RedHots® Display Light Units are an ideal way to light up your food preparation, holding, and display areas. Its durable and attractive construction makes it perfect for all your display lighting needs.

Eagle's RedHots® Display Lights are made of an extruded aluminum housing with a mirror finish reflector for maximum brightness, and come complete with shatter-resistant light bulbs.

All display light units are shipped completely assembled with field wiring connections and are ready to be mounted. Please see the "Mounting Location" section of this manual for mounting clarification. Eagle Group provides a 7/8" and 1 1/8" knockout on the switch side of the unit for non-cord & plug units along with a lit rocker switch for operator control.

Safety precautions in this manual are preceded by the words **WARNING** and **CAUTION**, printed in boldface type, and should be read with care. **WARNING** indicates there is a possibility of personal injury. **CAUTION** indicates that damage to the unit can occur.

END MODEL SPECIFICATIONS:

All Display Light Units are offered in 120-volt with 60-watt light bulbs. Please refer to the catalog for all model numbers. See the legend below for details on the model numbers.

Model number description:

prefix length lights remote connection

RHDL - 18 - I - R - CP

Legend:

-I = incandescent light bulbs or "-H" for halogen light bulbs

-R = remote switch box

-CP = cord & plug

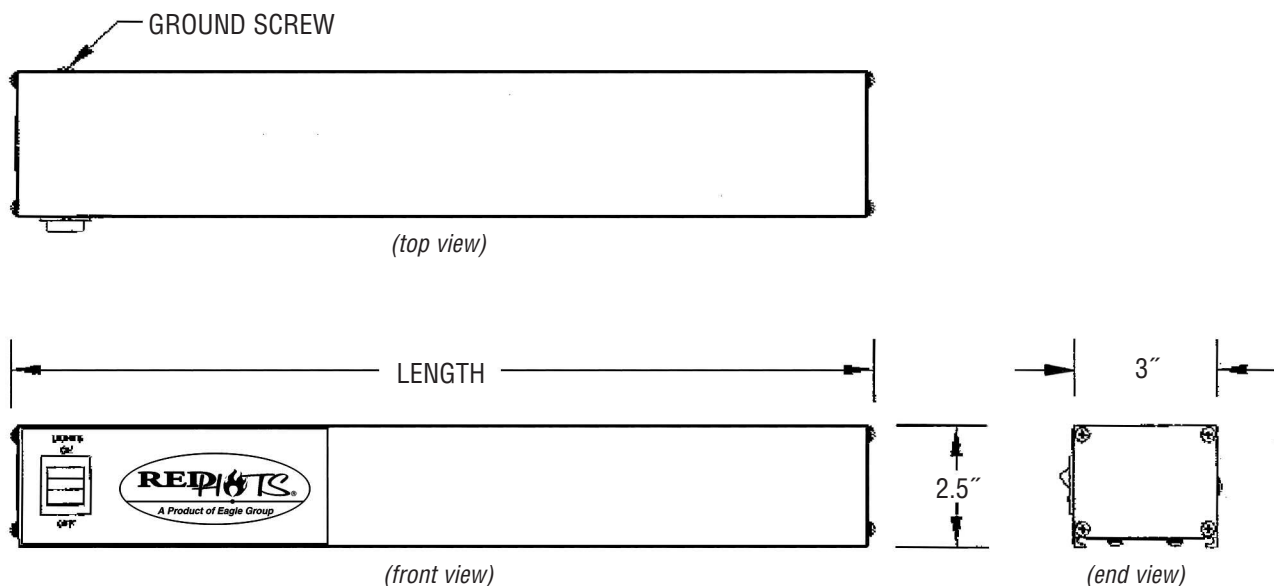

RedHots® Display Light Units

OPERATING MANUAL AND INSTRUCTIONS

ELECTRICAL REQUIREMENTS



WARNING



To conform to national and local electrical codes, please consult a licensed electrical contractor for proper installation. Failure to do so may result in personal injury, fire, damage to the unit, or code violations.

FOR UNITS WITHOUT CORD & PLUG:

Following UL, NEC and local codes, install a copper supply wire temperature rated no lower than 90C to the Display Light Unit. Eagle Group supplies a 7/8" and 1 1/8" knockout on the left side of the aluminum housing and 6" long, 12-gauge pigtails with a separate ground screw. Conduit not supplied by Eagle Group.

FOR UNITS WITH CORD & PLUG:

Plug the unit into an appropriate 120V outlet.

Optional Control Switch Box Connection

(When ordering a display light unit with a remote, the main unit does NOT contain any switches.)

Following UL, NEC and local codes, install a copper supply wire temperature rated no lower than 90C to the control box. Eagle Group supplies a 7/8" and 1 1/8" knockout on the sides of the aluminum housing and 6" long, 12-gauge pigtails with a separate ground screw. The control box is made of 6063 aluminum and is 2 1/2" high x 3" deep. Conduit not supplied by Eagle Group.

Note: Do not connect a circuit operating at more than 150 volts to ground.

Note: The control switch box should be located and/or labeled so that it is clear to the operator which control switch box operates its corresponding Display Light Unit.

MOUNTING LOCATIONS

CAUTION:

If a display light unit is to be installed above a steam table, install so that there is a minimum of 8" clearance between the bottom of unit and top of steam table. Do not install display light unit any closer than 1" from any adjacent non-heat producing surface.

Use only the mounting brackets supplied by Eagle Group to maintain the proper clearances from the mounting surface.



WARNING - FIRE HAZARD



To avoid personal injury or damage to the unit, do not use the top surface of the display light unit as a storage surface, as it is not a load-bearing component.

RedHots® Display Light Units

OPERATING MANUAL AND INSTRUCTIONS

MOUNTING LOCATIONS (continued)

CHAIN-MOUNTED UNITS (available only with cord & plug connection)

Chain supplied by Eagle Group is constructed of sufficient strength to securely hold the weight of the RedHots® Display Light Unit when properly mounted (ordered separately by the foot under Eagle Group part # 358372.)

Securely fasten the chain to surface above the area that the display light unit will be located over. Please be sure that the chain is located so that the unit will be suspended at a safe and proper distance from any walls and working surface. (Distances provided in “Mounting Location” section of this manual—page 3.)

Remove the top two screws on the ends of the display light unit. Locate the chain mounting tab and fasten the two screws back into the unit. Repeat this process for both ends.

Attach the overhead chain to the tabs and hang as required. Maintain safe mounting heights to prevent discoloration or damage to a combustible surface and the unit itself.



WARNING



Chain must be #8 trade size and securely fastened, or unit could come loose and possibly cause personal injury or damage to the unit. Chain should be attached to structure capable of holding minimum 50 pounds.

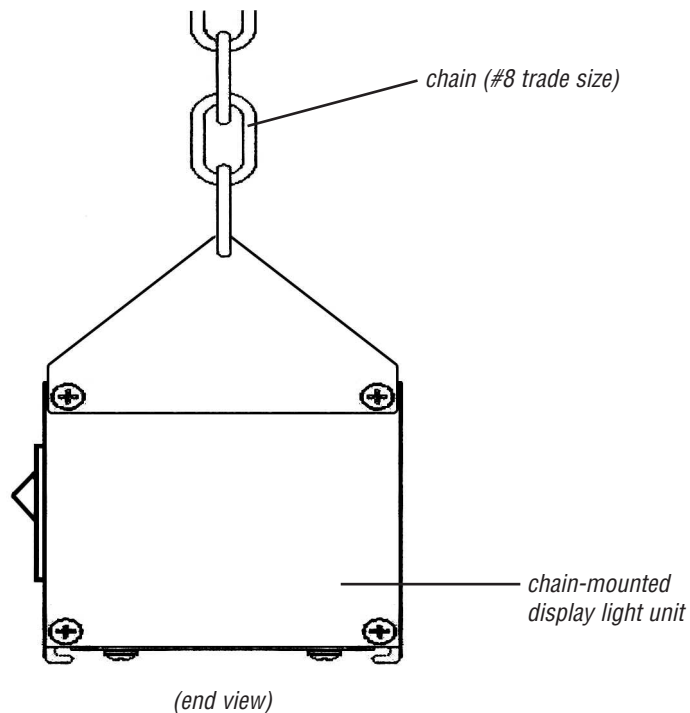

RedHots® Display Light Units

OPERATING MANUAL AND INSTRUCTIONS

MOUNTING LOCATIONS (continued)

UNDER SHELF OR CABINET MOUNT

When mounting the display light unit under a shelf or inside a cabinet, be sure to use the mounting brackets provided by Eagle Group to maintain the offset from the shelf or the wall. The bracket is adjustable up to three positions in case of a front roll, or you require the switch lowered.

Remove the top two #8-32 screws on the display light unit on both sides. Align the holes in the bracket to the holes in the display light unit as shown below and securely mount the screws.

Secure the display light bracket using #1/4-20 screws (not provided by Eagle Group) to ensure a secure installation.

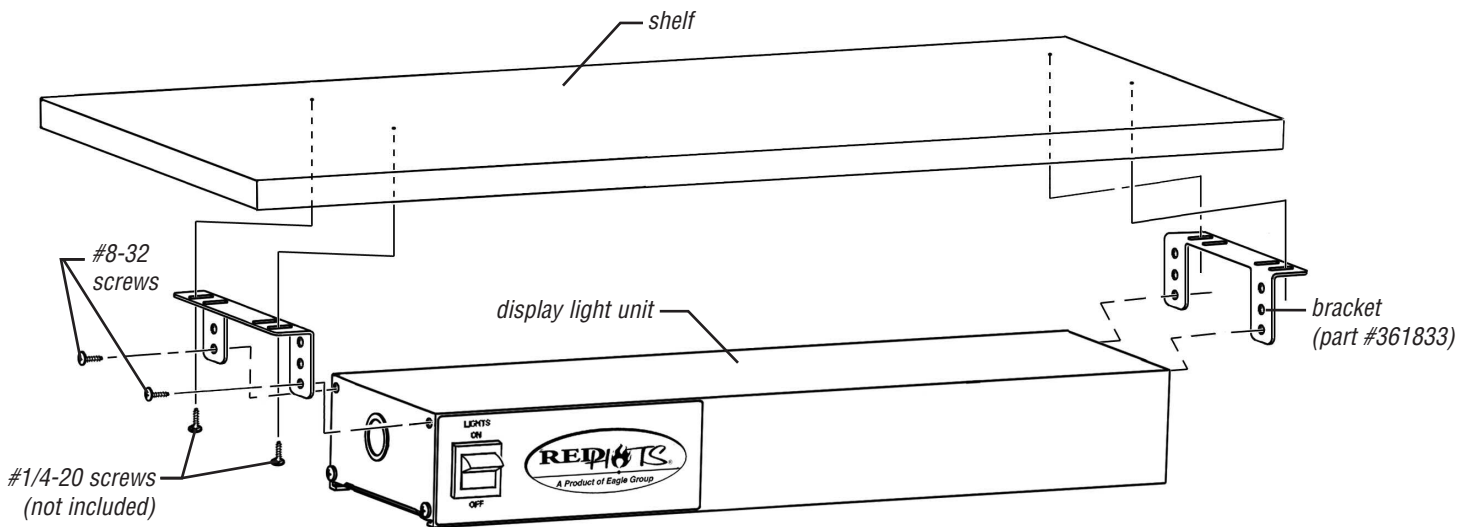

RedHots® Display Light Units

WIRING DIAGRAMS

CLEANING

To preserve the finish and life of your RedHots® Display Light Unit, Eagle recommends cleaning the exterior surfaces by wiping them down with a damp cloth, making sure that the unit has been turned off and has cooled down. Harder-to-remove stains may be removed by using a non-abrasive aluminum cleaner. Abrasive cleaners can scratch and ruin the finish, making it possible for dirt buildup to occur.

CAUTION:

Be sure the unit is off and to wait until the lights have cooled down enough to handle before cleaning.

REPLACEMENT PARTS

Incandescent Light Bulbs - Part #354547

Halogen Light Bulbs - Part #361798

Switch - Part #354552



WARNING



To replace a light bulb, simply unscrew the bad bulb and replace with a new one. Use only bulbs provided by Eagle Group. These bulbs are specially coated with Teflon to comply with NSF standards and to prevent breakage or possible food contamination.

Under Shelf Mounting Bracket - Part Number: 361833

Chain Mounting Bracket - Part Number: 361832

For all other replacement parts, please contact our Parts & Service Center.

SAFETY PRECAUTIONS

Only use mounting methods and materials described and suggested by Eagle Group to prevent personal injury or damage to the unit and its components.

Be sure that all specified clearances have been maintained for safe operation and to prevent combustion of work surfaces.

RedHots® Display Light Units

WIRING DIAGRAMS

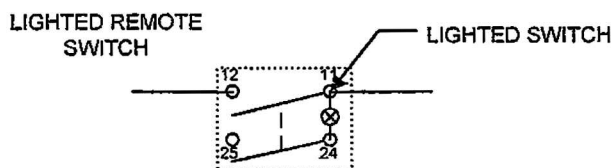
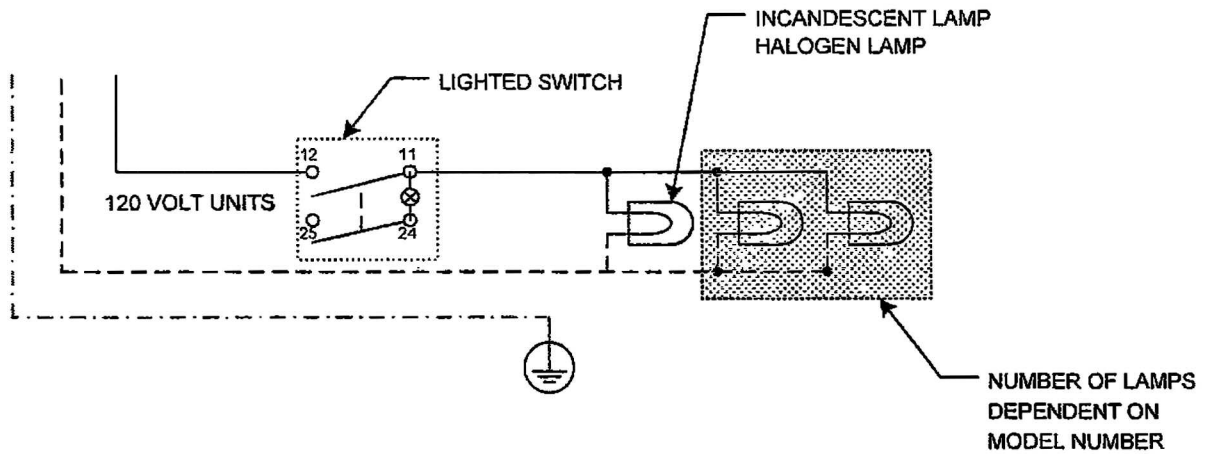
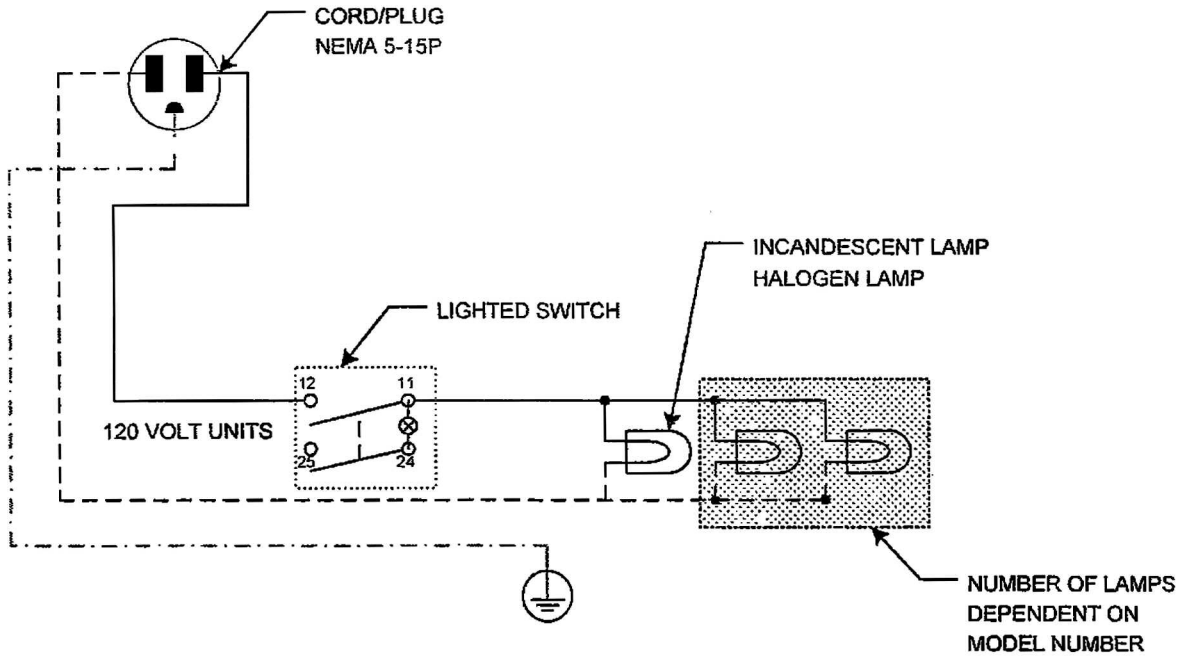

RedHots® Display Light Units

WARRANTY

Eagle Foodservice Equipment warrants to the original owner that goods supplied hereunder manufactured by Eagle Foodservice Equipment will be free from defects in materials and workmanship for a period of **one year** from date of original installation, not to exceed 18 months from date of shipment from the factory. Eagle Foodservice Equipment will replace, without charge, any defective parts or component material, upon demonstration to its satisfaction that a breach of warranty did not exist.

Please refer to our website (www.eaglegrp.com) for a listing of the authorized parts and service centers near you or call the factory for assistance.

This warranty does not cover any cost associated with maintenance, misuse, abuse, improper installation, pilot light adjustments, pilot outage, improper ventilation, adjustments, alteration, calibration, wrong voltage, wrong gas, voltage or gas conversions, resetting of circuit breakers or safety controls, overtime charges, travel charges on portable equipment, mileage in excess of 100 miles, operation contrary to the installation and operating instructions, damage caused by flood, fire, or acts of God. This warranty shall not apply if the nameplate has been removed or altered.

There are no warranties, which extend beyond these warranties. All other expressed or implied warranties, including those of merchantability or fitness for a particular purpose, which exceed the warranties stated above, are disclaimed by Eagle Foodservice Equipment and excluded from this agreement. No employee or agent of ours has any authority to make any representation or warranty, which exceeds the warranties stated above.

NO EAGLE FOODSERVICE EQUIPMENT MAY BE RETURNED EXCEPT UPON WRITTEN
AUTHORIZATION FROM EAGLE FOODSERVICE EQUIPMENT.



• 100 Industrial Boulevard, Clayton, Delaware 19938-8903 U.S.A. • www.eaglegrp.com
• Phone: 302/653-3000 • (Foodservice/SpecFAB) 800/441-8440 • (MHC/Retail) 800/637-5100
• Fax: 302/653-2065