

Security Modules with Flip-Up Door

ASSEMBLY INSTRUCTIONS

CAUTION

INSPECT CONTENTS IMMEDIATELY AND FILE CLAIM WITH DELIVERING CARRIER FOR ANY DAMAGE. **SAVE YOUR BOX AND ALL PACKING MATERIALS.** YOU ARE RESPONSIBLE FOR DAMAGE TO YOUR UNIT IF RETURNED IMPROPERLY PACKED.

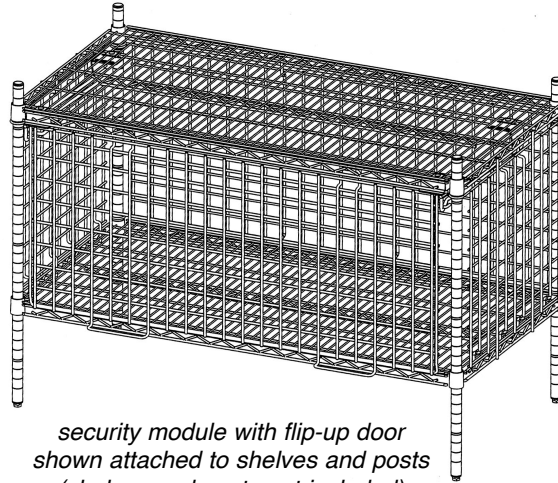

*security module with flip-up door
shown attached to shelves and posts
(shelves and posts not included)*

Parts List

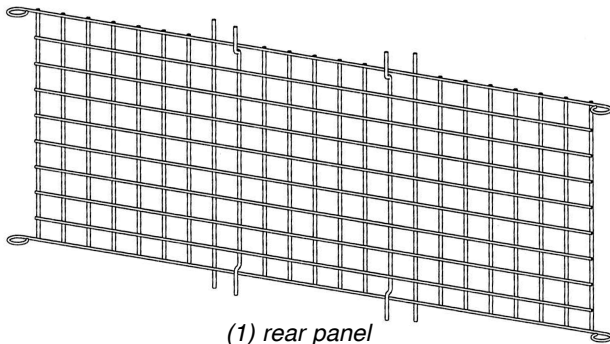

(1) rear panel

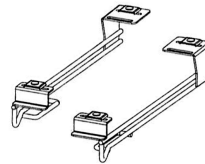

(1) pair of tracks

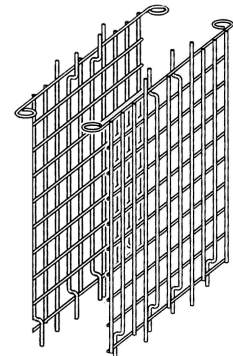

(2) end panels

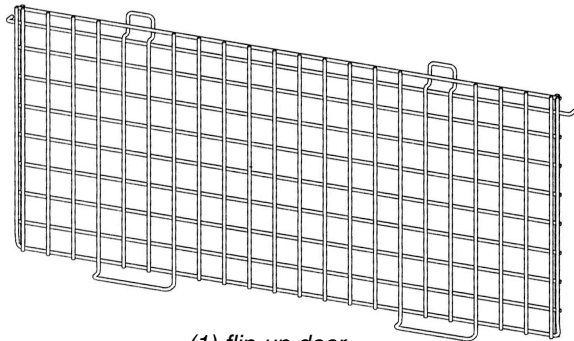

(1) flip-up door

Hardware included (actual size)

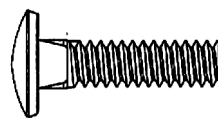

(4) carriage bolts

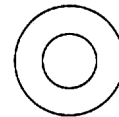

(4) washers



(4) lock nuts

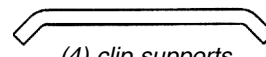

(4) clip supports

EG10087 Revised 10/23



- 100 Industrial Boulevard, Clayton, Delaware 19938-8903 U.S.A.
- Phone: 302/653-3000 • 800/441-8440 • Fax: 302/653-2065
- www.eaglegrp.com • www.eaglegrpnews.com • www.eaglemhc.com

Security Modules with Flip-Up Door

ASSEMBLY INSTRUCTIONS

Step 1 - Determine location of security module by positioning lower wire shelf (not included) accordingly onto posts.

Note: Measure 20" from top of shelf to accommodate for the rest of the assembly.

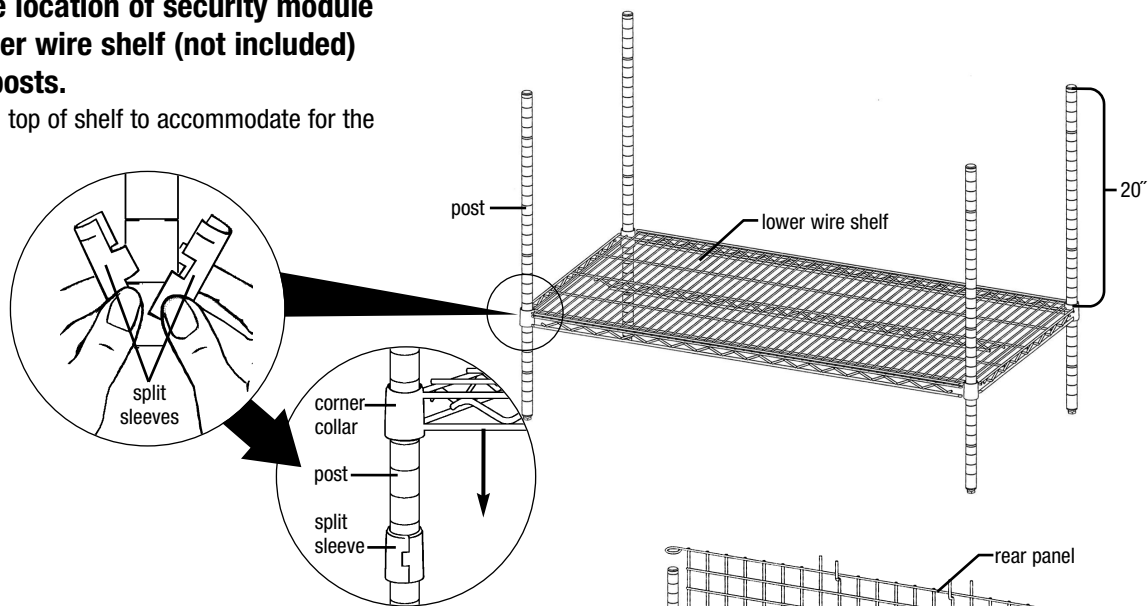

Step 2 - Install rear panel by sliding loops over and down the rear posts, with the bottom of the panel locking into lower wire shelf.

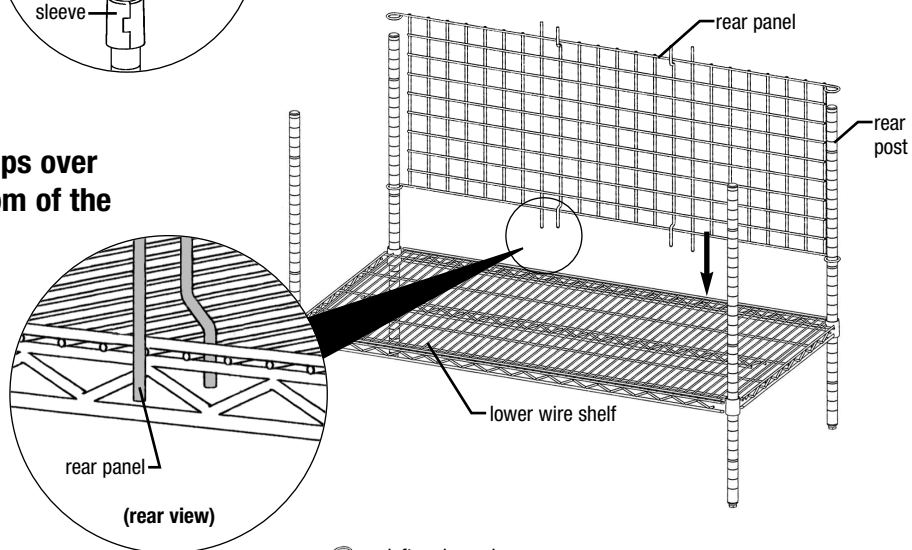

Step 3 - Install end panels by sliding loops over and down the front and rear posts on each end, with the bottom of each panel locking into lower wire shelf.

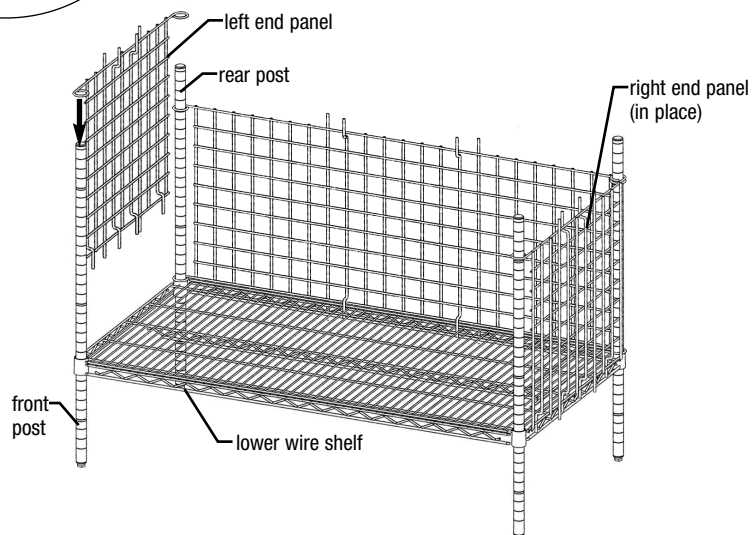

(continued on next page)

Security Modules with Flip-Up Door

ASSEMBLY INSTRUCTIONS

Step 4 - Attach door tracks to top wire shelf, but do not tighten hardware.

NOTE: Top shelf not included.

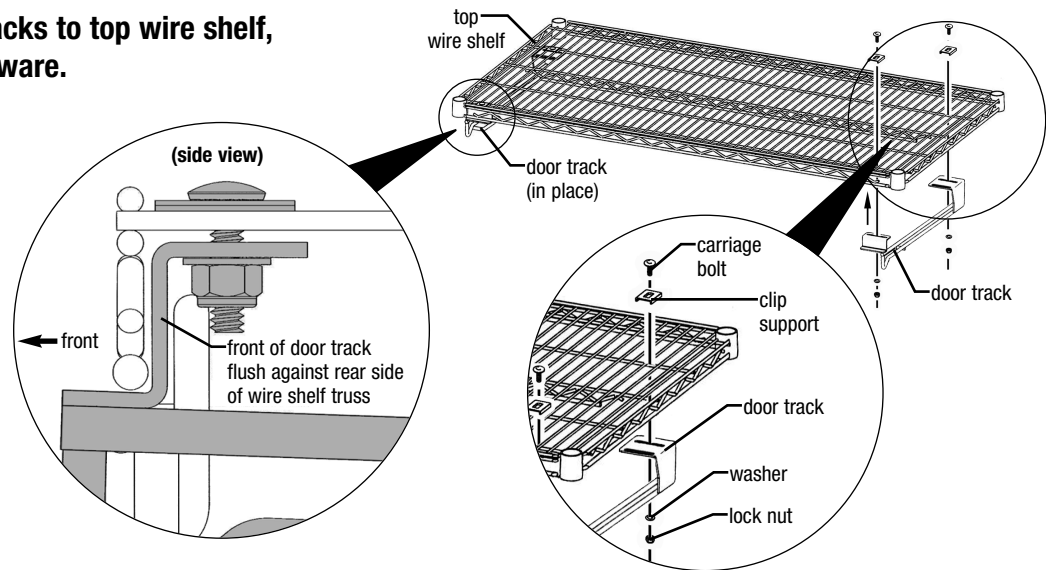

Step 5 - Install door into track/shelf assembly. Tighten all hardware.

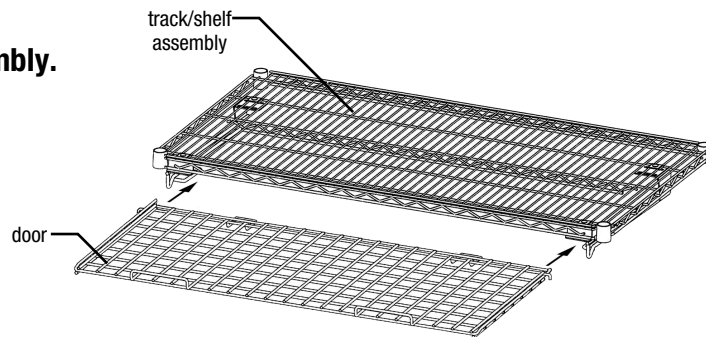

Step 6 - Install door/track/shelf assembly to unit. Rear panel and end panels should lock into top wire shelf.

NOTE: For easier installation, door should be pushed in all the way.

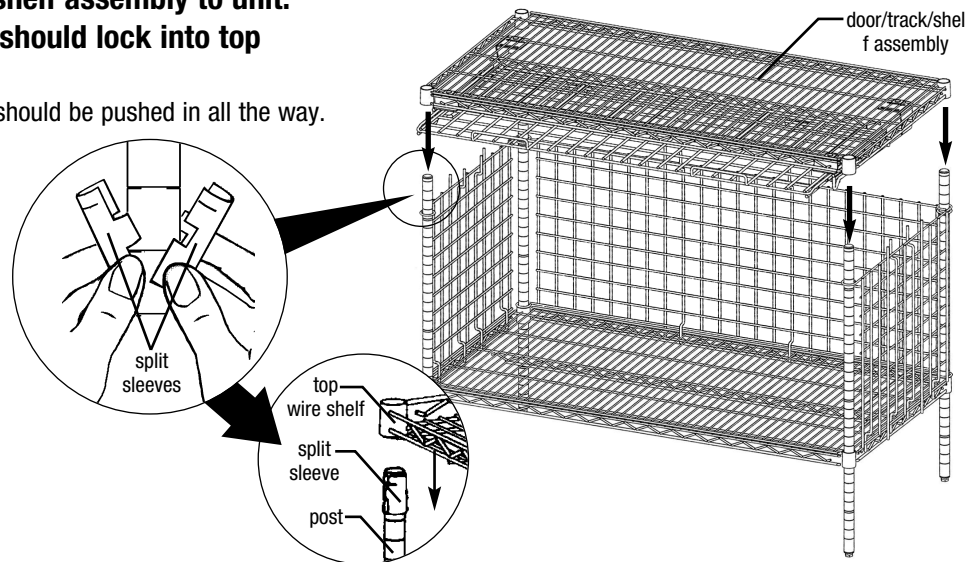

(End)

Assembly is complete.

Security Modules with Flip-Up Door

ASSEMBLY INSTRUCTIONS

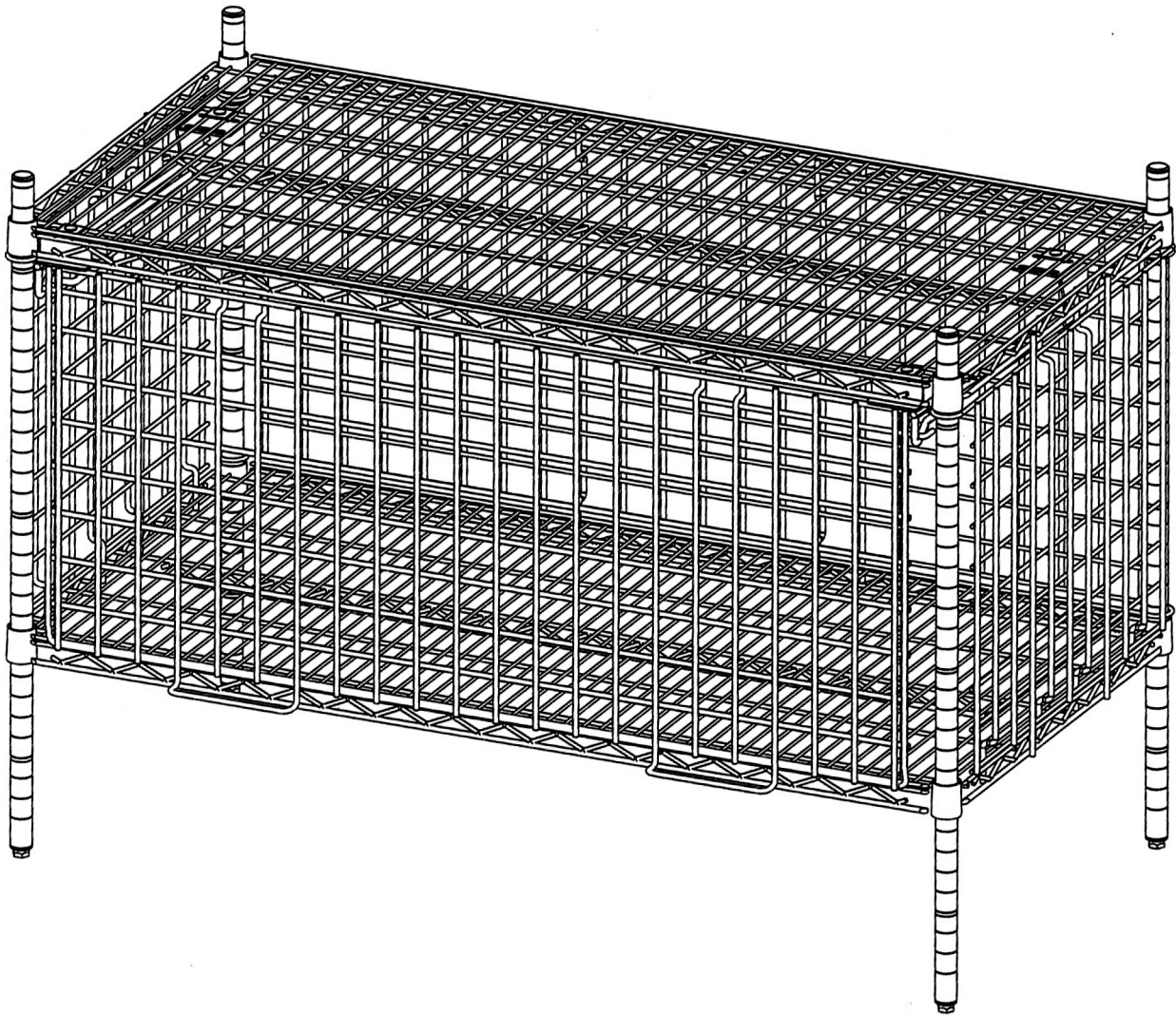

- 100 Industrial Boulevard, Clayton, Delaware 19938-8903 U.S.A.
- Phone: 302/653-3000 • 800/441-8440 • Fax: 302/653-2065
- www.eaglegrp.com • www.eaglegrpnews.com • www.eaglemhc.com