

OPERATING AND INSTALLATION INSTRUCTIONS**CAUTION**

INSPECT CONTENTS IMMEDIATELY AND FILE CLAIM WITH DELIVERING CARRIER FOR ANY DAMAGE.

SAVE YOUR BOX AND ALL PACKING MATERIALS.

YOU ARE RESPONSIBLE FOR DAMAGE TO YOUR UNIT IF RETURNED IMPROPERLY PACKED.

Retain this manual for future reference.

Contact this factory, the factory representative or Eagle's authorized service center in your area to perform maintenance and repairs.

This unit has been manufactured in accordance with Underwriters Laboratories and NSF International standards, consult local electrical and sanitation codes for compliance. Please reference the electrical specifications in this manual to insure that proper amperage and voltage is used for your application. Built-in units must be installed in compliance with the NEC.

UNPACKING INSTRUCTIONS

Thank you for purchasing our high quality Eagle heated drawer. Please inspect the unit for any damage before and after unpacking. If any damage is found, please contact the delivering carrier immediately.

- To unpack the heated drawer, first remove the four 3/8-16 bolts, using a wrench, that secure the unit to the crate located on the underside of the crating (freestanding unit only).
- Carefully remove the crating from the unit so as to not damage the unit.
- Remove all clear plastic wrap from the exterior of the unit.
- Remove any tape or adhesive that may be holding the drawers closed.
- Please remove any warranty or instruction information from the drawers prior to use and store in safe location for future reference.
- Remember to properly sanitize and clean the unit before use.

Read all instructions carefully before installing and operating the product.

REPLACEMENT PARTS LISTING

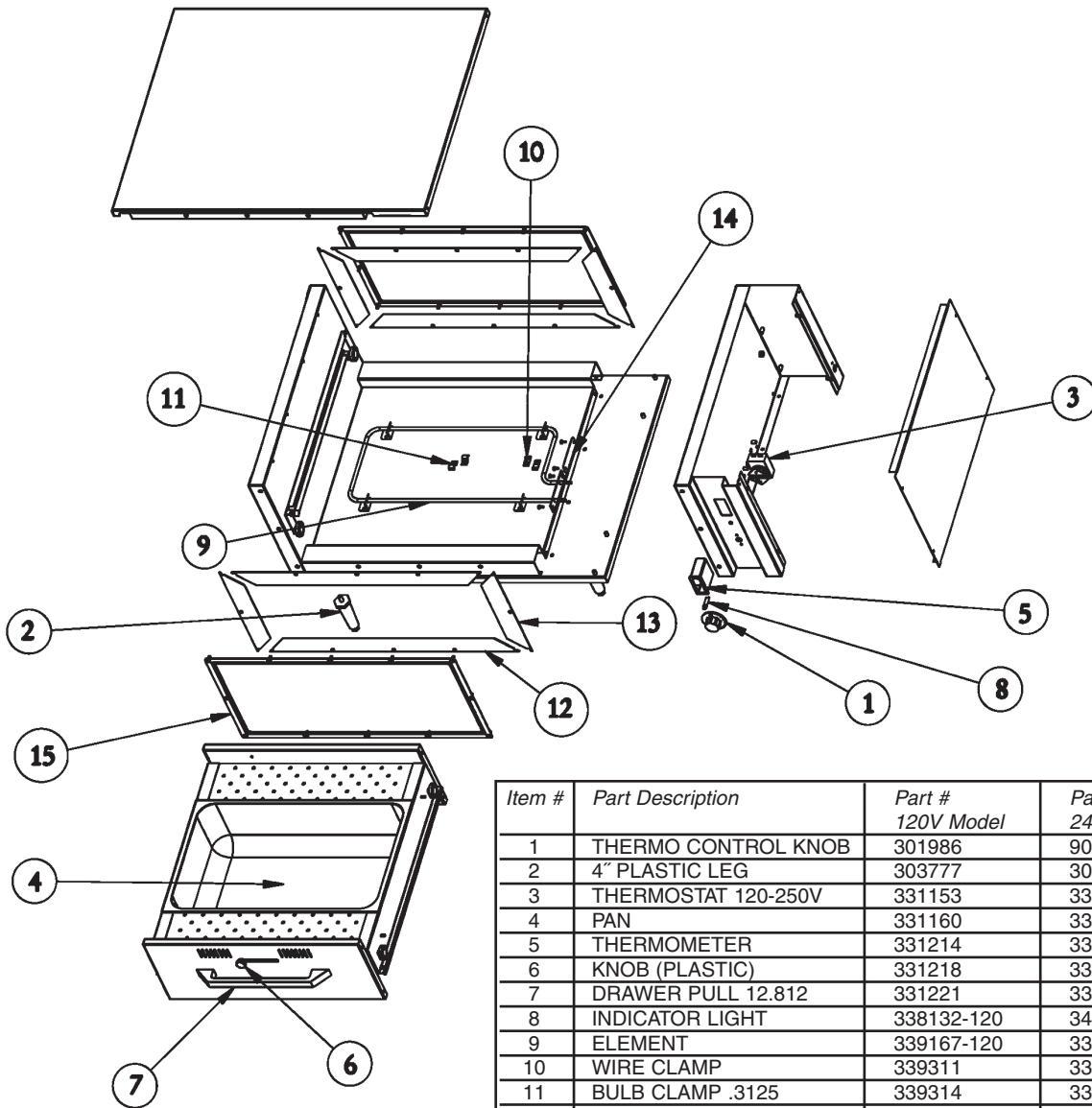

Item #	Part Description	Part # 120V Model	Part # 240V Model
1	THERMO CONTROL KNOB	301986	901986
2	4" PLASTIC LEG	303777	303777
3	THERMOSTAT 120-250V	331153	331153
4	PAN	331160	331160
5	THERMOMETER	331214	331214
6	KNOB (PLASTIC)	331218	331218
7	DRAWER PULL 12.812	331221	331221
8	INDICATOR LIGHT	338132-120	346293-240
9	ELEMENT	339167-120	339168-240
10	WIRE CLAMP	339311	339311
11	BULB CLAMP .3125	339314	339314
12	GASKET	368512	368512
13	GASKET	368513	368513
14	HOLD DOWN PLATE	368545	368545
15	GASKET RING	368546	368546

INSTALLATION INSTRUCTIONS

This unit has been manufactured in accordance with Underwriters Laboratories and NSF International standards, consult local electrical and sanitation codes for compliance. Please reference the electrical specifications in this manual to insure that proper amperage and voltage is used for your application. Built-in units must be installed in compliance with the NEC.

Freestanding Units

1. Install the legs into the bottom of the unit by threading them into the nut inserts and tightening securely.
2. Locate the unit in a desired area within reach of an appropriately sized electrical outlet.
3. Place unit on a flat, level surface and check that the unit is level both left-to-right and front-to-back. Adjust the feet as needed for a level installation.

CAUTION!

LEGS MUST BE INSTALLED PRIOR TO THE OPERATION OF THE UNIT. TO AVOID DAMAGE, DO NOT LAY UNIT ON ITS FRONT OR BACK SIDE.

PLUG CONFIGURATIONS

Freestanding Units

All freestanding units are factory supplied with a cord and plug. Please check to make sure that the plug matches the receptacle:

- 1) 120V units supplied with a NEMA 5-15P plug configurations.
- 2) 240V units supplied with a NEMA 6-15P plug configurations.

CAUTION!

FOR FREESTANDING UNITS, ONLY PLUG UNIT INTO A RECEPTACLE OF COMPATIBLE VOLTAGE AND PLUG CONFIGURATION. IF THE APPROPRIATE RECEPTACLE IS NOT AVAILABLE, CONTACT A CERTIFIED ELECTRICIAN TO INSTALL THE CORRECT OUTLET.

Electrical Rating Chart

Model	Volts	Watts	Amps	Plug
DWP-1x-	120	450	3.8	NEMA 5-15P
DWP-1x-	240	450	1.9	NEMA 6-15P

OPERATION FOR ALL MODELS

1. On freestanding models, plug unit into an electrical outlet of the correct voltage, size and plug configuration.
2. To turn the power on, turn the thermostat control to the desired setting. See chart below for Recommended Settings.
3. Allow the unit 30-40 minutes to reach operating temperature.
4. Adjust the drawer vents for desired humidity by unscrewing front door knob to unlock the vent and slide the vent to desired location. Opening the vent all the way allows maximum moisture to escape.

Food Holding Guide

Product	Rec. Storage Temp.	Heat Type	Vent Control
Rolls, Hard	160-185°F (71-85°C)	Dry	Open
Rolls, Soft	150-175°F (66-79°C)	Moist	Open-Half
Vegetables	175-185°F (66-85°C)	Moist	Open-Half
Meat, Poultry	165-185°F (74-85°C)	Dry	Open
Fish	165-185°F (74-85°C)	Moist	Closed
Casseroles	150-175°F (66-79°C)	Dry	Open
Pies, Desserts	160-185°F (71-85°C)	Dry	Open

Food Holding Capacity

for standard drawer

Product	Capacity
Dinner Rolls	6-8 Dozen
Ribs	25-30 lbs.
Potatoes	3 to 3-1/2 Dozen

CLEANING AND MAINTENANCE

WARNING

To avoid injury, turn the power off and allow unit to cool before cleaning or performing maintenance. On freestanding units, unplug the electrical cord from the power source as well.

To preserve the finish of the Drawer Warmer, it is recommended that the surface be wiped daily with a damp cloth. Food pans should be removed and washed. Stubborn stains may be removed with a good non-abrasive cleaner. Hard to reach areas should be cleaned with a small brush and mild soap.

CAUTION!

ABRASIVE CLEANERS COULD SCRATCH THE FINISH OF THE DRAWER WARMER.

CLEANING AND MAINTENANCE (CONTINUED)

Removing Lime and Mineral Deposits

Note: If the water used has an excessive amount of lime or mineral content, use the following instructions for periodic cleaning and de-liming of the water pan.

1. Turn off the power. On freestanding units, unplug the cord from the power source.
2. After the unit has cooled down, remove the water pan.
3. Fill the water pan with a mixture of water and delimer.
4. Allow the pan to stand with the mixture for the recommended period of time. The time required will depend on the solution used and the amount of deposits in the pan. Check delimer manufacturer for specific directions.
5. After the deliming period, drain the solution from the pan.
6. Continue to fill and rinse the pan with water only, until the pan is clean.
7. Install the pan into the unit. On freestanding units, plug the power cord into the receptacle and fill the pan as usual for daily operation.

Note: The lime and mineral content of the water used for daily operation will determine how often the de-liming procedure must be performed.

EAGLE MODEL # MATRIX AND DIMENSIONS

DWP-1R = Control and plug to right of drawer

DWP-1L = Control and plug to left of drawer

Models & Dimensions

Model #	Length	Depth	Height
DWP-1R-120	30-3/8"	23"	17-7/8"
DWP-1R-240			17-7/8"
DWP-1L-120	30-3/8"	23"	17-7/8"
DWP-1L-240			17-7/8"

WIRING DIAGRAM

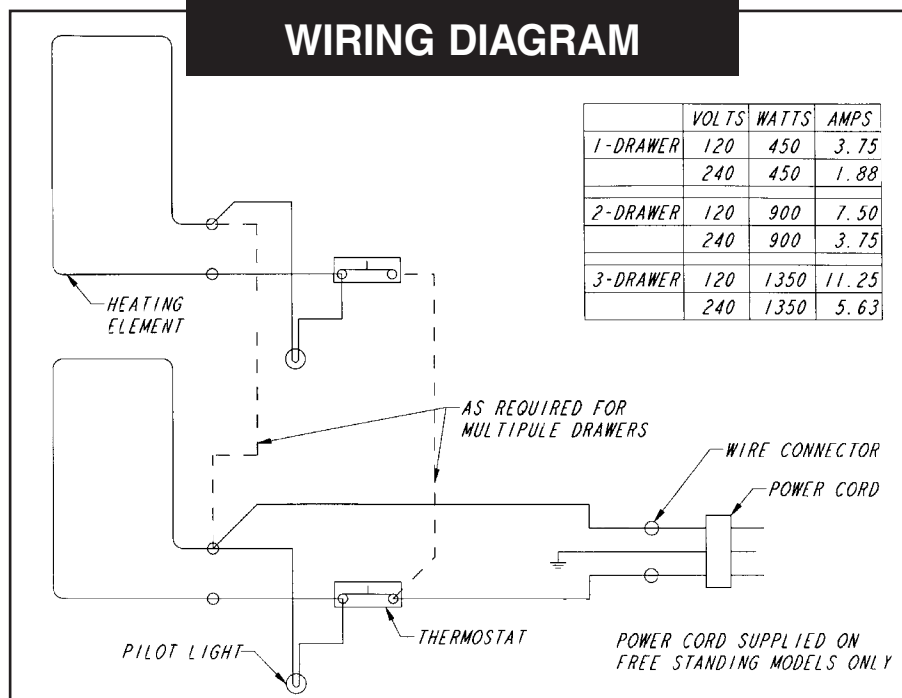

Profit from the Eagle Advantage®

• 100 Industrial Boulevard, Clayton, Delaware 19938-8903 U.S.A. • www.eaglegrp.com
 • Phone: 302/653-3000 • (Foodservice) 800/441-8440 • (MHC/Retail) 800/637-5100
 • Fax: 302/653-2065

Eagle Foodservice Equipment, Eagle MHC, SpecFAB®, and Retail Display are divisions of Eagle Group. ©2008 by the Eagle Group