

Piggyback Wall-Mounted Shelf Kits

ASSEMBLY INSTRUCTIONS

CAUTION

INSPECT CONTENTS IMMEDIATELY AND FILE CLAIM WITH DELIVERING CARRIER FOR ANY DAMAGE.
SAVE YOUR BOX AND ALL PACKING MATERIALS.
 YOU ARE RESPONSIBLE FOR DAMAGE TO YOUR UNIT IF RETURNED IMPROPERLY PACKED.

*** Please note: Hardware not included. ***

PLEASE NOTE:

Once the brackets are attached to the wall studs (as shown in **Step 1**), shelves can be positioned anywhere along the wall brackets without the use of fasteners.

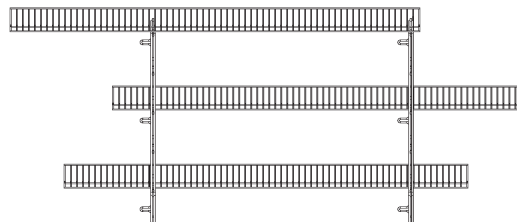

(FRONT VIEW)

Step 1 - Mount brackets in relation to studs behind wall, using bolts and washers —do not tighten hardware!

Note: Make sure to mount brackets at the same height. This will ensure level shelving.

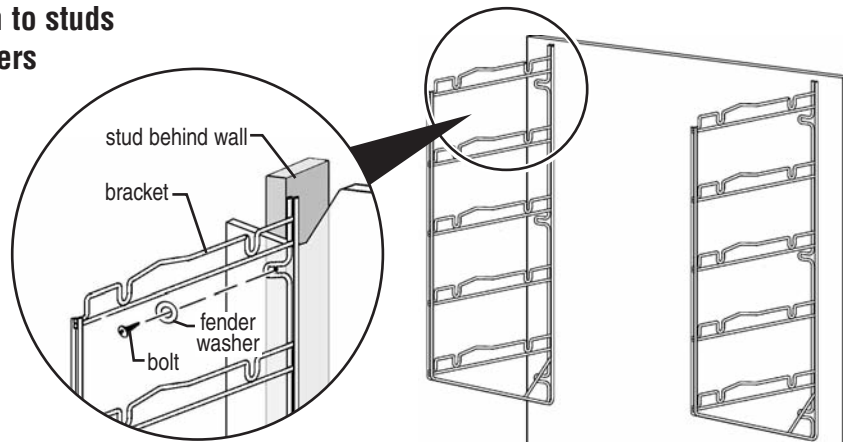

(continued on back page) 

Piggyback Wall-Mounted Shelf Kits

ASSEMBLY INSTRUCTIONS

Step 2 - Mount shelves to brackets.

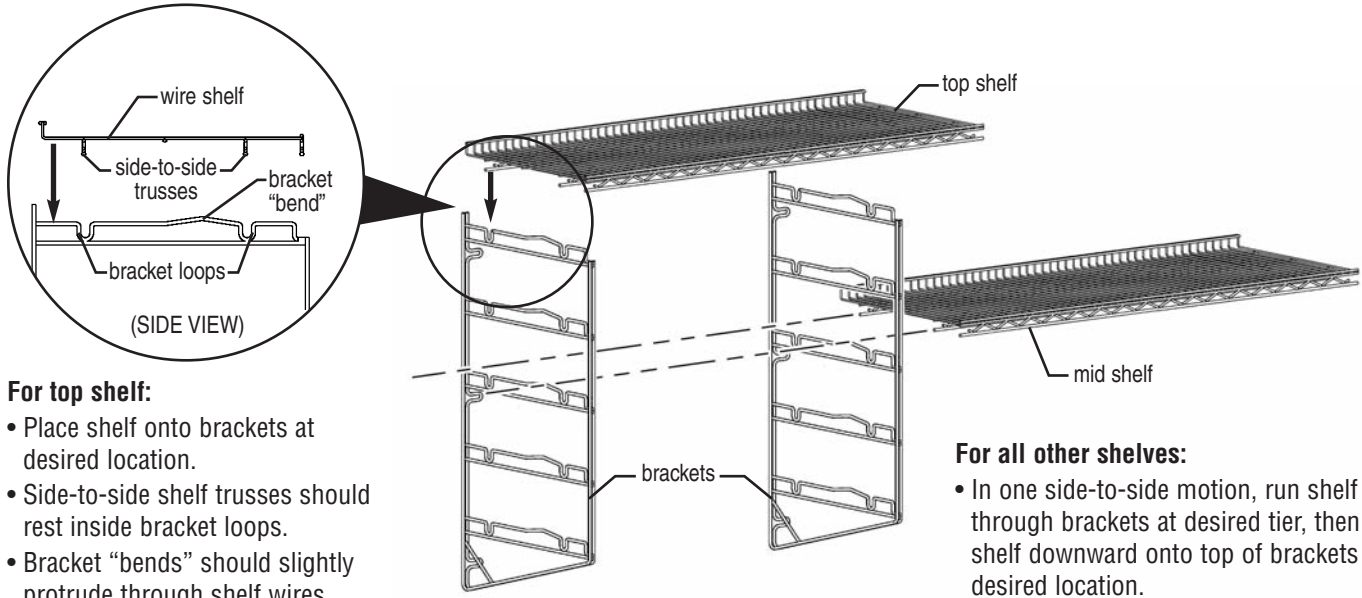

For top shelf:

- Place shelf onto brackets at desired location.
- Side-to-side shelf trusses should rest inside bracket loops.
- Bracket "bends" should slightly protrude through shelf wires.

For all other shelves:

- In one side-to-side motion, run shelf through brackets at desired tier, then place shelf downward onto top of brackets at desired location.
- Side-to-side shelf trusses should rest inside bracket loops.
- Bracket "bends" should slightly protrude through shelf wires.

Step 3 - Tighten all hardware.



Note: Wall mounted units must be attached to a properly constructed and sound wall. For walls constructed of wood or steel studs, the mounting points must be directly on the stud or suitable in-wall-grounds of plywood or sheet metal. Eagle Group cannot be held responsible for the failure of the device or any other devices due to improper installation.