



Profit from the Eagle Advantage®

Specification Sheet

Short Form Specifications

Eagle Spec-Bar® Modular Bar Die. Interior finish is heavy gauge type 304 stainless steel. Substructure is 12 gauge galvanized steel. Used to enclose and hide beer, soda, electrical, and plumbing lines in a chase incorporated into the unit.

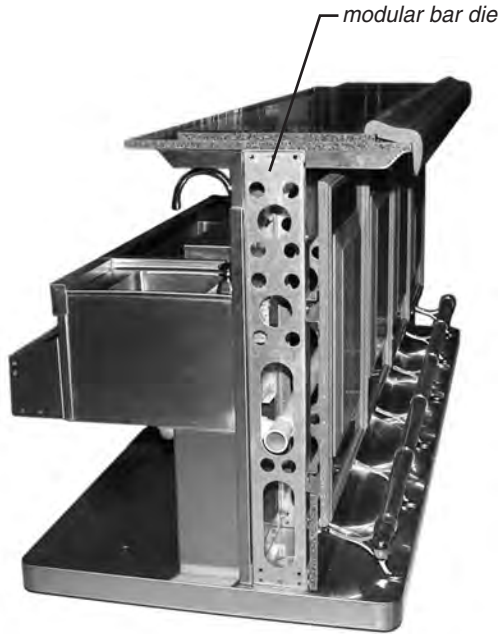

pedestal base style bar die shown with Spec-Bar® sink (not included), optional countertop, decorative millwork finish & bar rail, and foot rail (floor base shown for display only—not included)

Options / Accessories

- Countertop
- Millwork finish
- Stainless steel finish
- Decorative rails and fittings
- Decorative laminates
- Lights for customer's side
- Plug-in fluorescent lights for server's side

EAGLE GROUP
100 Industrial Boulevard, Clayton, DE 19938-8903 USA
Phone: 302-653-3000 • Fax: 302-653-2065
www.eaglegrp.com

Foodservice Division: Phone 800-441-8440
MHC/Retail Display Divisions: Phone 800-637-5100

For custom configuration or fabrication needs, contact our **SpecFAB® Division**.
Phone: 302-653-3000 • Fax: 302-653-3091 • e-mail: specfab@eaglegrp.com

Item No.:	_____
Project No.:	_____
S.I.S. No.:	_____

Spec-Bar® Modular Bar Die

Please call our SpecFAB® department at 800-441-8440 with your design requirements.

Design and Construction Features

- Operator's side finished in type 304 stainless steel for strength and corrosion resistance.
- Interior finish is 20 gauge type 304 stainless steel.
- Substructure is 12 gauge galvanized steel.
- Bar dies enclose and hide soda, beer, electrical and plumbing lines in a chase incorporated into the unit.
- Front of the bar can be covered by removable panels that provide easy access to the chase for future modifications and maintenance.
- Panels can be covered in a decorative laminate, an elegant wood millwork finish or a stunning stainless steel finish.
- On pedestal based style bar dies, equipment is mounted onto die before shipping. Simply connect sections and secure unit to floor.
- Add decorative brass or chrome rails and fittings to match any decor.
- Duplex outlets as requested.
- Low-voltage lighting available.
- Optional factory U.L. wiring and plumbing package.

Certifications / Approvals	
CUSTOM	

AUTOQUOTES

EG40.45 Rev. 04/11

Spec sheets available for viewing, printing or downloading from our online literature library at www.eaglegrp.com

Eagle Foodservice Equipment, Eagle MHC, SpecFAB®, and Retail Display are divisions of Eagle Group. ©2011 by the Eagle Group



Profit from the Eagle Advantage®

Item No.: _____
 Project No.: _____
 S.I.S. No.: _____

Spec-Bar® Modular Bar Die

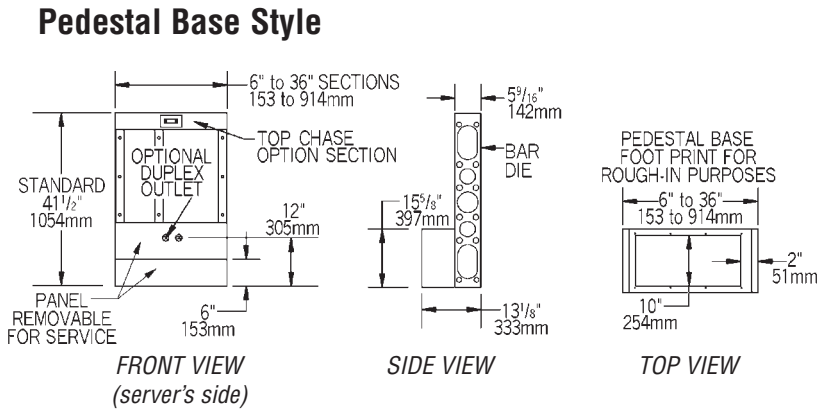
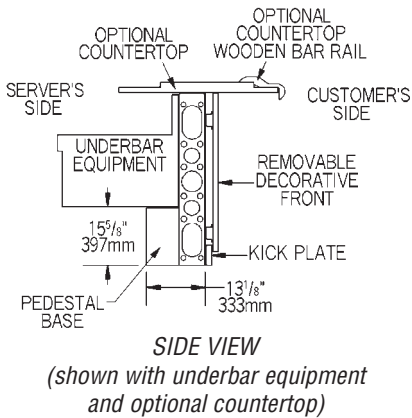
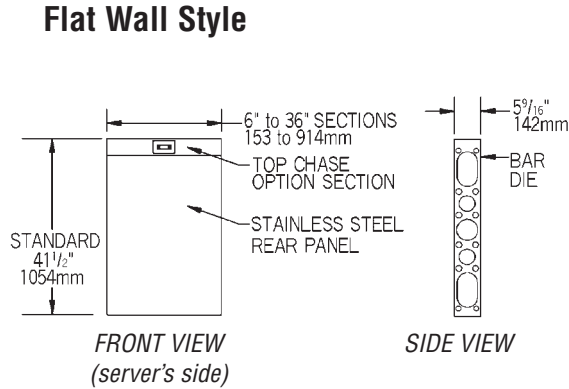
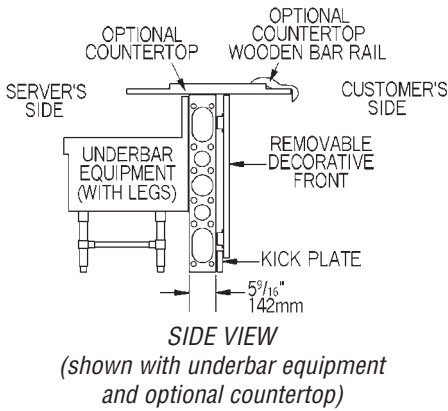

Top Chase Options

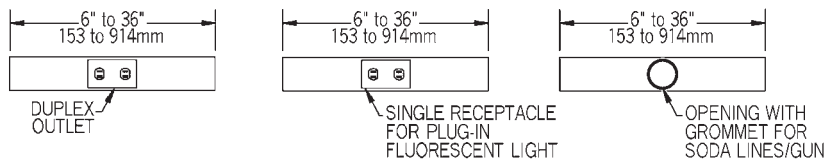

Note: Sections available in 6" to 36" (153 to 914mm) lengths, as line art illustrates. Units longer than 36" (914mm) require multiple pedestals.

EAGLE GROUP
 100 Industrial Boulevard, Clayton, DE 19938-8903 USA
 Phone: 302-653-3000 • Fax: 302-653-2065
 www.eaglegrp.com

Foodservice Division: Phone 800-441-8440
 MHC/Retail Display Divisions: Phone 800-637-5100

Printed in U.S.A.
 ©2011 by Eagle Group
 Rev. 04/11

Spec sheets available for viewing, printing or downloading from our online literature library at www.eaglegrp.com

Although every attempt has been made to ensure the accuracy of the information provided, we cannot be held responsible for typographical or printing errors. Information and specifications are subject to change without notice. Please confirm at time of order.