

WALSTOR®

Modular Wall System

INSTALLATION INSTRUCTIONS

CAUTION

INSPECT CONTENTS IMMEDIATELY AND FILE CLAIM WITH DELIVERING CARRIER FOR ANY DAMAGE.
SAVE YOUR BOX AND ALL PACKING MATERIALS.
 YOU ARE RESPONSIBLE FOR DAMAGE TO YOUR UNIT IF RETURNED IMPROPERLY PACKED.

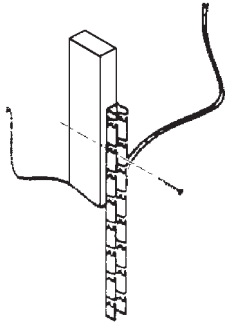

figure #1

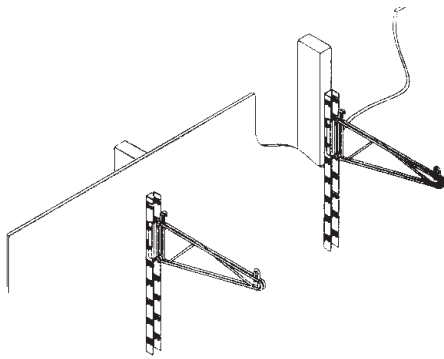

figure #2

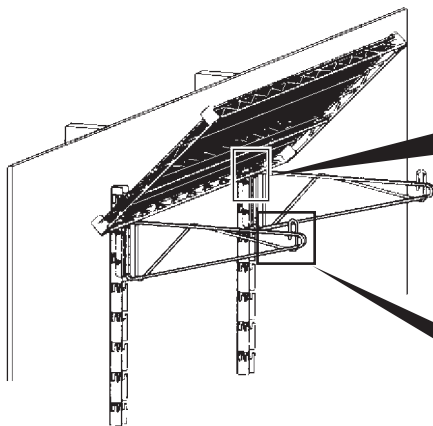

figure #3

- 1) Inspect location of wall on which WalStor® will be mounted. Concrete and masonry wall must be solid with no signs of deterioration. Walls constructed of wood or steel studs must not show signs of rust or rot. Molly bolt installation to drywall is not recommended. If mounting to concrete or masonry wall, skip to #3.
- 2) Locate the studs and mark their locations. Studs are generally located 16" or 24" center-to-center.
- 3) Unpack the vertical wall uprights. The uprights are to be mounted center to center with the wall studs (See figure #1). CAUTION! The vertical wall uprights must be fastened securely prior to mounting any shelving or accessories. EAGLE GROUP will not be held accountable for the failure to use the appropriate secure mounting method.
- 4) If optional wall mat is required, unpack and install in rear slots of vertical wall uprights.
- 5) Unpack the wire shelf bracket and place them on the vertical wall uprights. The wire shelf bracket pins will be located on the front set of slots on the vertical wall brackets. The slots located toward the rear of the vertical wall brackets are for the optional wall mats. (see figure #2)
- 6) Mount the shelf onto the wire shelf brackets, by tipping the rear of the shelf back to approximately 45 degrees (see figure #3). The rear shelf truss assembly must slip under the wire shelf bracket hooks (see figure #3a). Then lower down onto front of bracket (see figure #3b). Snap collar plugs in front collars of wire shelf to complete installation.

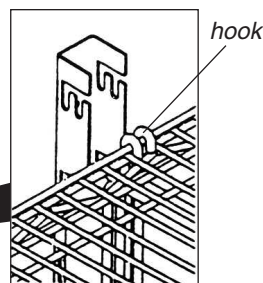

figure #3a

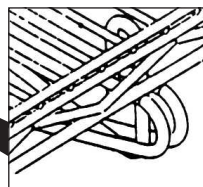

figure #3b

Note: Wall mounted units must be attached to a properly constructed and sound wall. For walls constructed of wood or steel studs, the mounting points must be directly on the stud or suitable in-wall grounds of plywood or sheet metal. Eagle Group cannot be held responsible for the failure of the device or any other devices due to improper installation.

To install optional grid shelf,
 see back page. 

WALSTOR® Modular Wall System

INSTALLATION INSTRUCTIONS

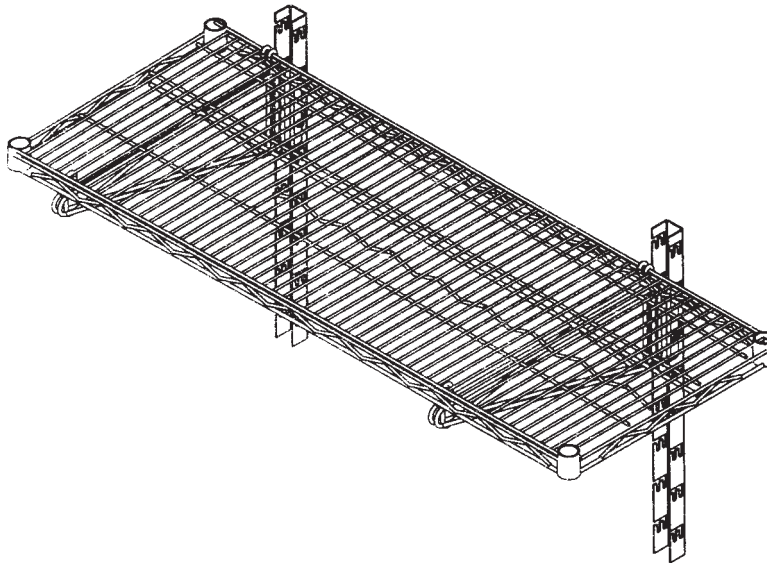

CAUTION:

Weight limit = 150 pounds per shelf

A secure means of fastening the vertical wall uprights prior to mounting any shelving or accessories must be utilized. Eagle Group will not be held responsible for vertical wall uprights pulling away from the wall.

Grid Shelf Mounting Instructions

- 1) Unpack the grid shelf and the support brackets.
- 2) Hook the rear of the grid shelf over the wall mat wires.
- 3) Insert the support bracket between the top and bottom truss wires on the front of the grid shelf.
- 4) Tilt the front of the shelf up and hook the support brackets to the wall mat (see *figure #5*.)

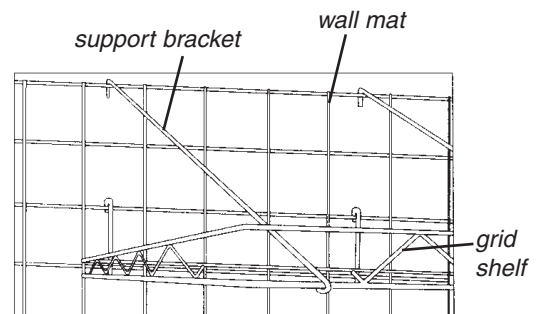

figure #5

(End)