

Microwave Prep Table

ASSEMBLY INSTRUCTIONS

CAUTION

INSPECT CONTENTS IMMEDIATELY AND FILE CLAIM WITH DELIVERING CARRIER FOR ANY DAMAGE.
SAVE YOUR BOX AND ALL PACKING MATERIALS.
YOU ARE RESPONSIBLE FOR DAMAGE TO YOUR UNIT IF RETURNED IMPROPERLY PACKED.

Parts List

item #	qty	description	part no.
#1	3	14" x 48" wire overshelves	1448C
#2	1	30" x 48" solid work surface	SS3048S
#3	2	30" x 48" wire undershelves	3048C
#4	2	74" rear posts	P74-C
#5	2	33" front posts	P33-C
#6	2	40" front overshelf posts	OSP40-C
#7	4	foot slides	A200024
#8	1	12" x 24" wire grid panel (for side of unit)	WM1224-C
#9	1	24" x 48" wire grid panel (for rear of unit)	WM2448-C
#10	5	shelf dividers	SD14-C
#11	3	supply bins	A203877
#12	3	bin holders	PBH
#13	8	bag of four (4) split sleeves	A200816
#14	8	grid panel clamps	A210098
#15	4	4"-long display hooks	MDH-4
#16	2	14"-long spice racks	SR14

Step 1 - Assemble bottom undershelf to #7 groove on all posts.

Snap split sleeves onto #7 groove on posts.
 • The wider part of the taper goes toward the bottom.
 • Make sure rib on split sleeve is seated into a groove on the post.
 Note: The number covered by the split sleeve indicates approximate height of shelf.

Step 2 - Assemble top undershelf to #19 groove on all posts.

Repeat Step 1, attaching split sleeves onto #19 groove on posts.

(continued on Page 2)

EG9867 Revised 07/10

Microwave Prep Table

ASSEMBLY INSTRUCTIONS

Step 3 - Attach work surface to #31 groove on rear posts (top groove on front posts).

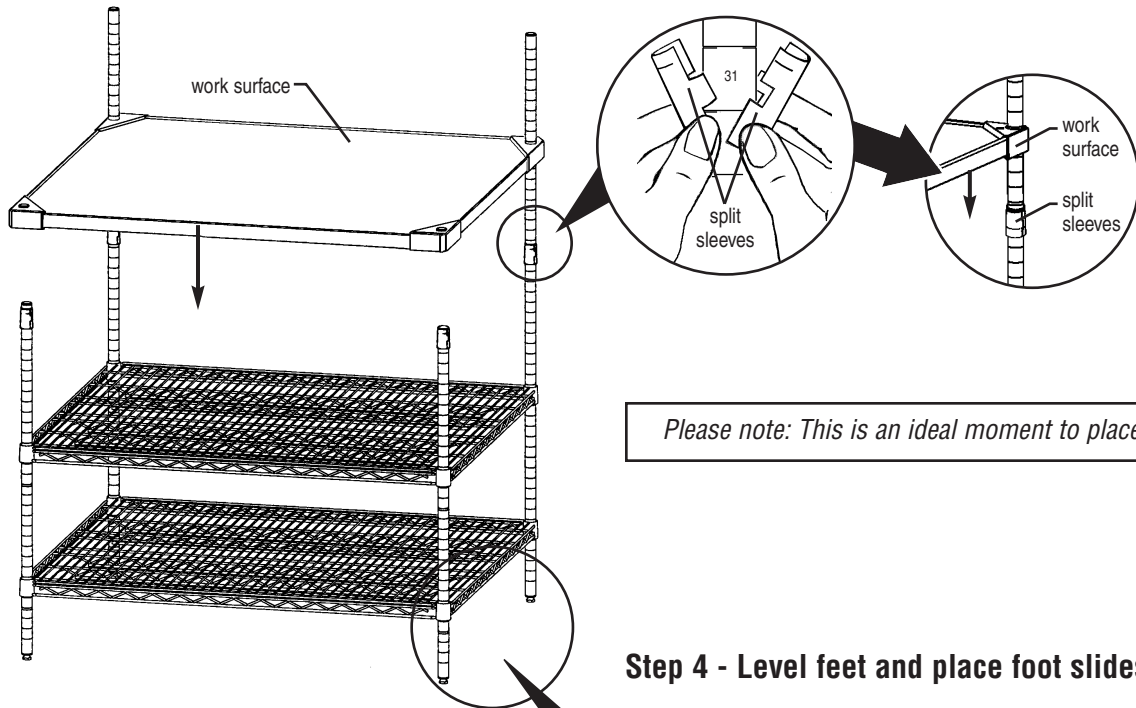

Step 4 - Level feet and place foot slides under posts.

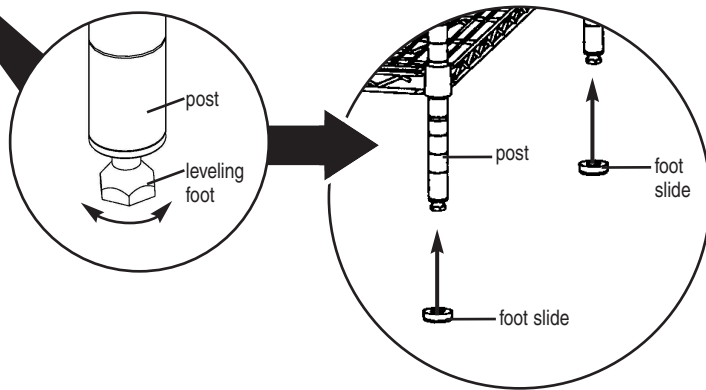

Assembly of the table base is complete.

(continued on Page 3)

Microwave Prep Table

ASSEMBLY INSTRUCTIONS

Step 5 - Assemble front overshelf posts, grid panel clamps, and overshelves—working from bottom to top.

Please note: Groove #s seen on 74" rear posts differ from groove #s on 40" front overshelf posts. The "Groove #" reference in the Step 5 illustration below pertains only to the REAR posts. For Steps 5A, C, E, F, and G: When installing split sleeves onto the front overshelf posts, match the heights to the rear posts' groove #s listed in illustration.

Referring to illustration, assemble in the following order:

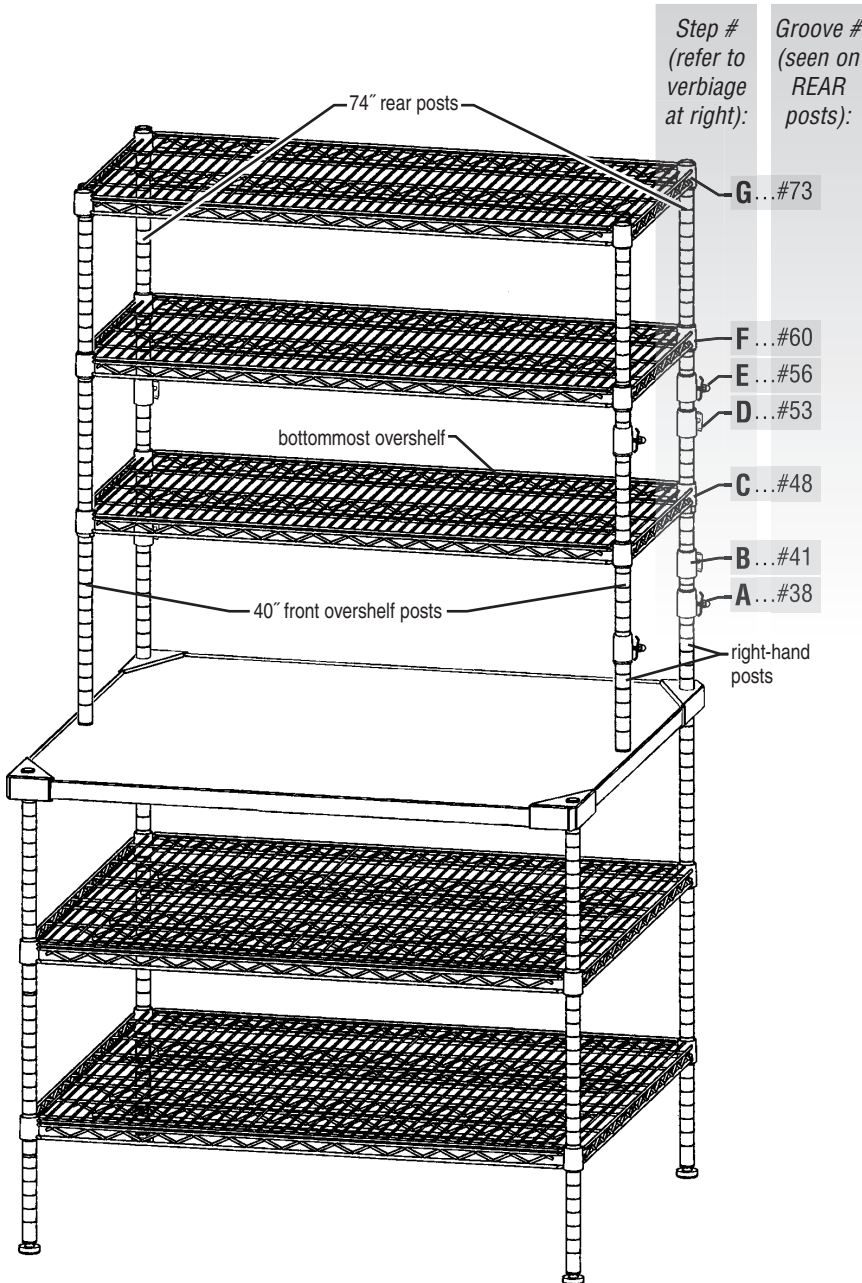

A) Attach bottommost grid panel clamps for side grid panel.

- Snap split sleeves onto right-hand posts.
- Slide grid panel clamps down posts and onto split sleeves, making sure they face outward.

B) Attach bottommost grid panel clamps for rear grid panel.

- Snap split sleeves onto rear posts.
- Slide grid panel clamps down posts and onto split sleeves, making sure they face outward.

C) Attach bottommost overshelf.

- Snap split sleeves onto all four posts.
- Slide overshelf down posts and onto split sleeves.

D) Attach topmost grid panel clamps for rear grid panel.

- Snap split sleeves onto rear posts.
- Slide grid panel clamps down posts and onto split sleeves, making sure they face outward.

E) Attach topmost grid panel clamps for side grid panel.

- Snap split sleeves onto right-hand posts.
- Slide grid panel clamps down posts and onto split sleeves, making sure they face outward.

F) Attach mid overshelf.

- Snap split sleeves onto all four posts.
- Slide overshelf down posts and onto split sleeves.

G) Attach top overshelf.

- Snap split sleeves onto topmost groove on all four posts.
- Seat topmost overshelf onto split sleeves.

(continued on back page)

Microwave Prep Table

ASSEMBLY INSTRUCTIONS

Step 6 - Attach rear grid panel.

- Loosen nut on each grid panel clamp as needed.
- Make sure the top of the grid panel lines up with the mid overshelf.
- Tighten nut on all grid panel clamps.

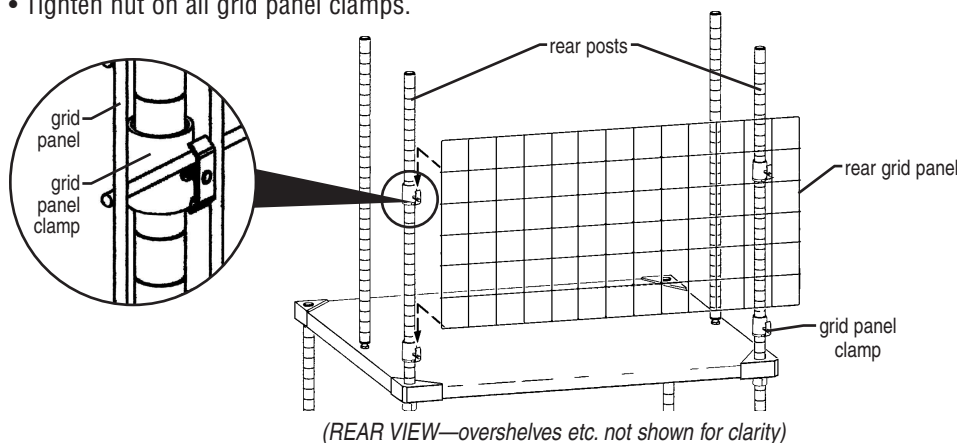

Step 7 - Attach side grid panel.

Repeat Step 6, making sure the side grid panel lines up with the rear grid panel.

Step 8 - Attach dividers onto mid overshelf.

- Place divider onto mid overshelf at desired location.
- Snap the front and rear tabs onto top side-to-side wire trusses of shelf.

Repeat Step 8 to attach remaining dividers.

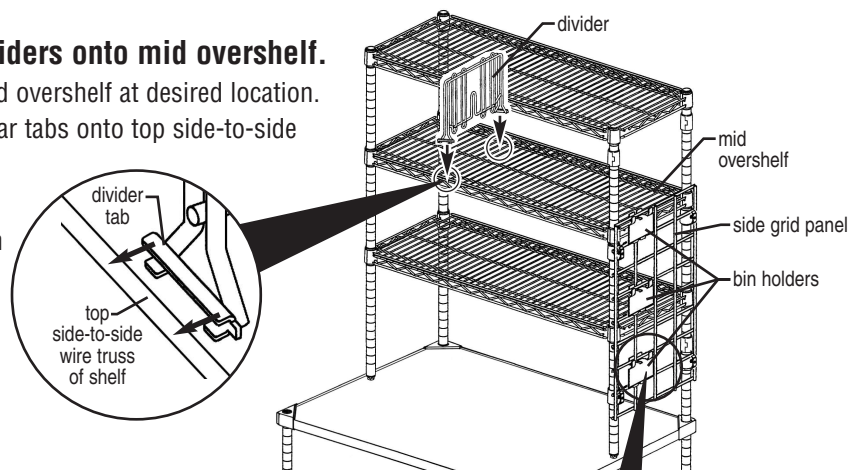

Step 9 - Attach bin holders to side grid panel and hang supply bins.

Refer to Step 8 illustration for typical locations of bin holders.

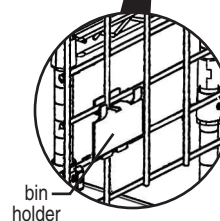

Step 10 - Hang hooks, racks, etc. onto grid panels where desired.

Assembly is complete.

(End)