

# Drive-Through Task Workstation

## ASSEMBLY INSTRUCTIONS

### CAUTION

INSPECT CONTENTS IMMEDIATELY AND FILE CLAIM WITH DELIVERING CARRIER FOR ANY DAMAGE.  
**SAVE YOUR BOX AND ALL PACKING MATERIALS.**  
YOU ARE RESPONSIBLE FOR DAMAGE TO YOUR UNIT IF RETURNED IMPROPERLY PACKED.

### Parts List

item #	qty	description	part no.
#1	2	14" x 60" wire overshelves	1460Z
#2	1	36" x 60" solid work surface	SS3660G
#3	1	12" x 60" cantilever shelf	CS1260-C
#4	1	36" x 60" wire undershelf	3660Z
#5	2	74" rear posts	P74-Z
#6	2	41" front overshelf posts	P41-Z
#7	2	33" front posts	P33-Z
#8	14	supply bins	A203877
#9	2	bin hanger rails	BH60C
#10	6	bag of four (4) plastic split sleeves	A200816
#11	2	"S"-hooks	A200012
#12	1	wire basket	WB

### Step 1 - Mount bottom undershelf.

Attach split sleeves onto #5 groove on 33" front posts and on 74" rear posts.

- The wider part of the taper goes toward the bottom.
- Make sure rib on split sleeve is seated into groove on the post.

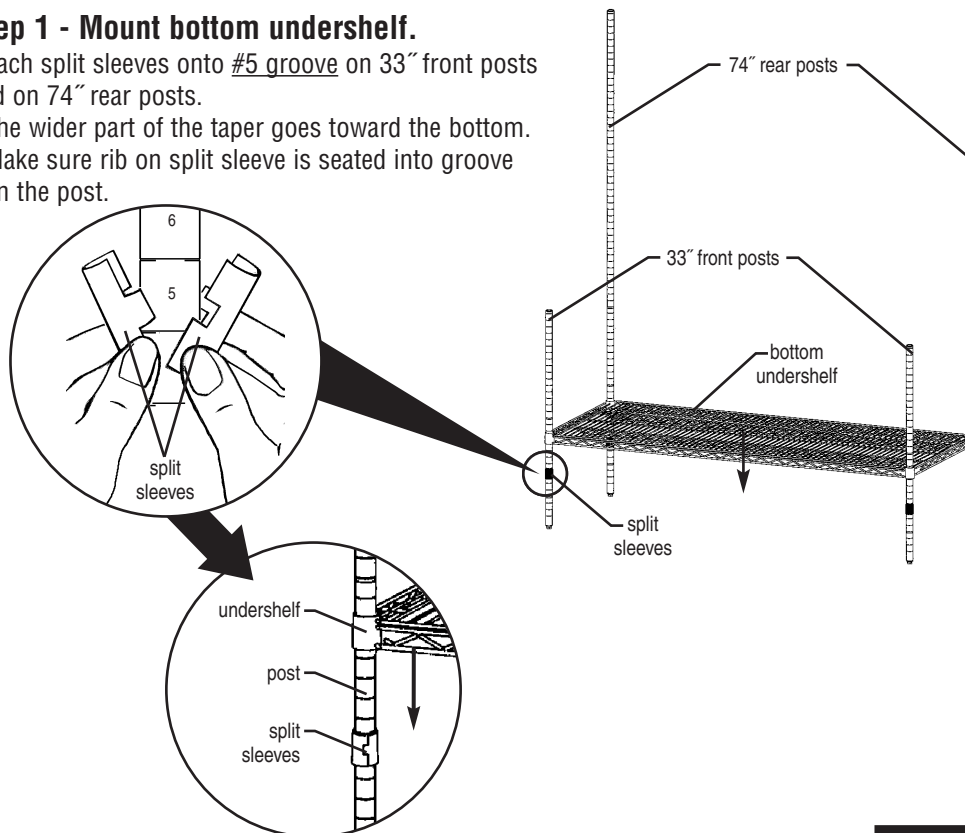

(continued on page 2)

EG9869 Revised 07/10

# Drive-Through Task Workstation

## ASSEMBLY INSTRUCTIONS

### Step 2 - Mount cantilever undershelf.

Attach split sleeves onto #25 groove on 33" front posts.

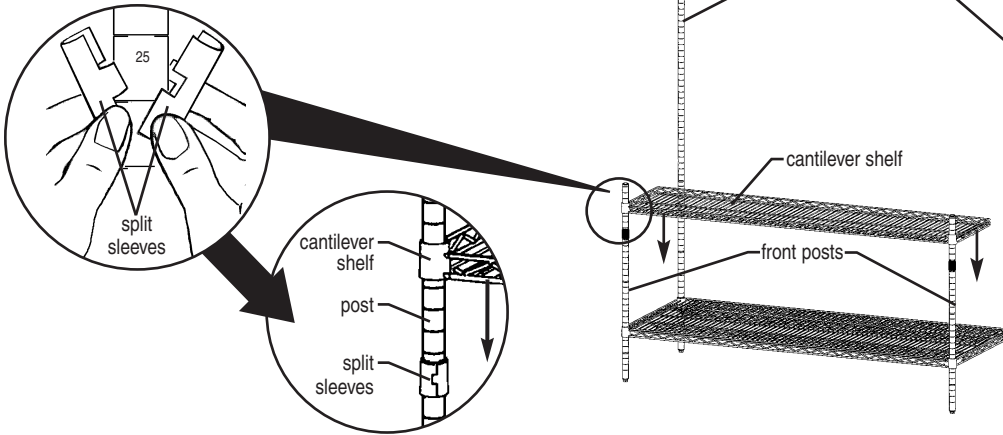

### Step 3 - Mount tabletop.

Snap split sleeves onto #32 groove on rear posts (topmost groove on front posts).

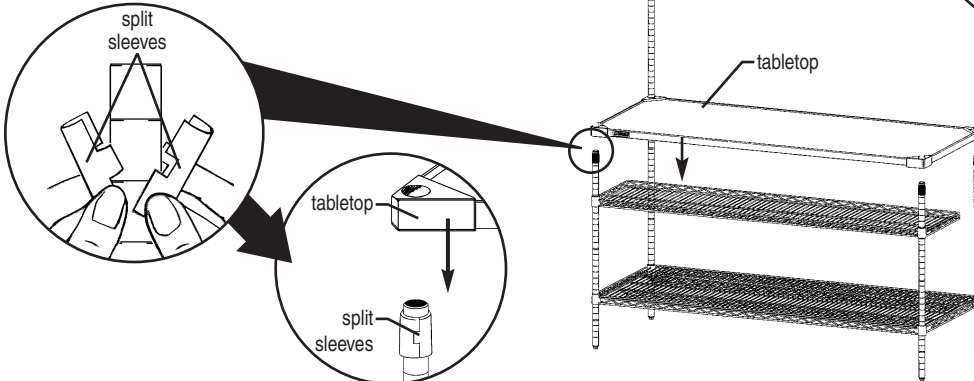

### Step 4 - Mount bottom hanger rail.

Snap split sleeves onto #40 groove on rear posts.

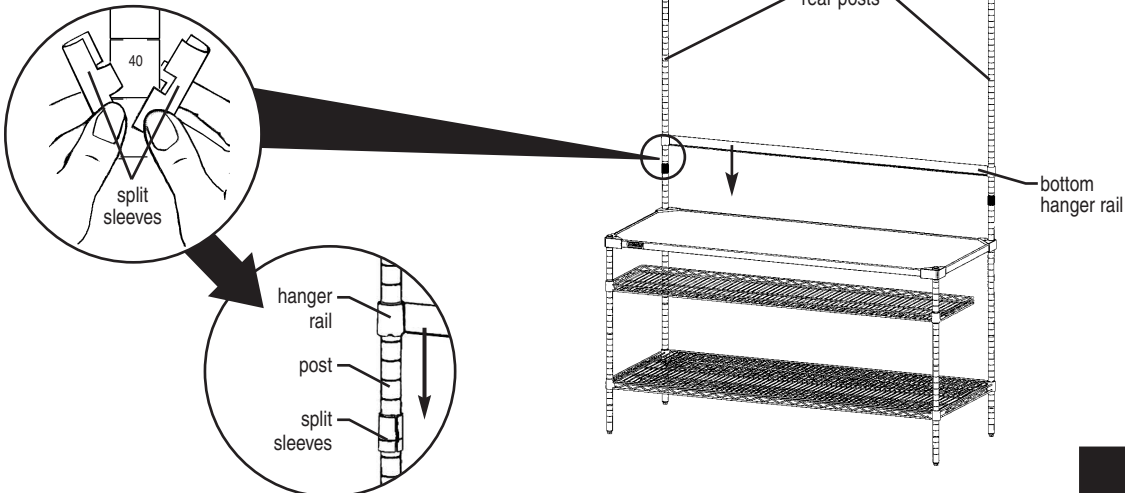

(continued on page 3)

# Drive-Through Task Workstation

## ASSEMBLY INSTRUCTIONS

### Step 5 - Mount top hanger rail.

Snap split sleeves onto #46 groove on rear posts.

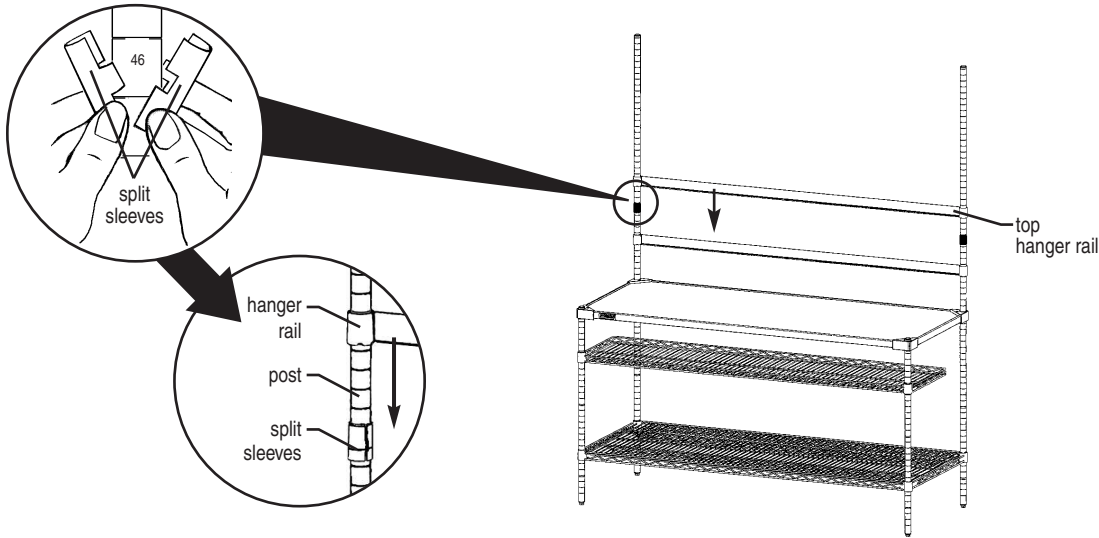

### Step 6 - Mount bottom overshelf and 41" posts.

Snap split sleeves onto #52 groove on rear posts.

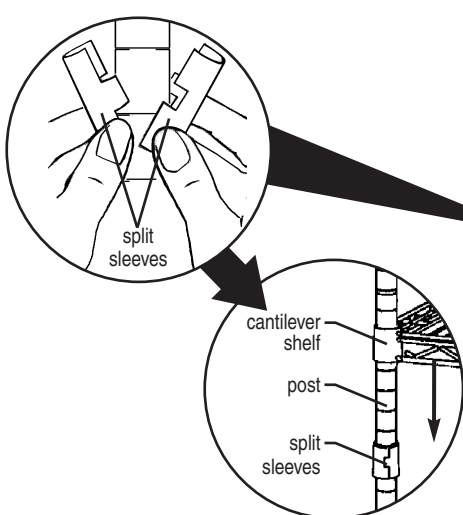

### Step 7 - Mount top overshelf.

Snap split sleeves onto top groove on all four posts.

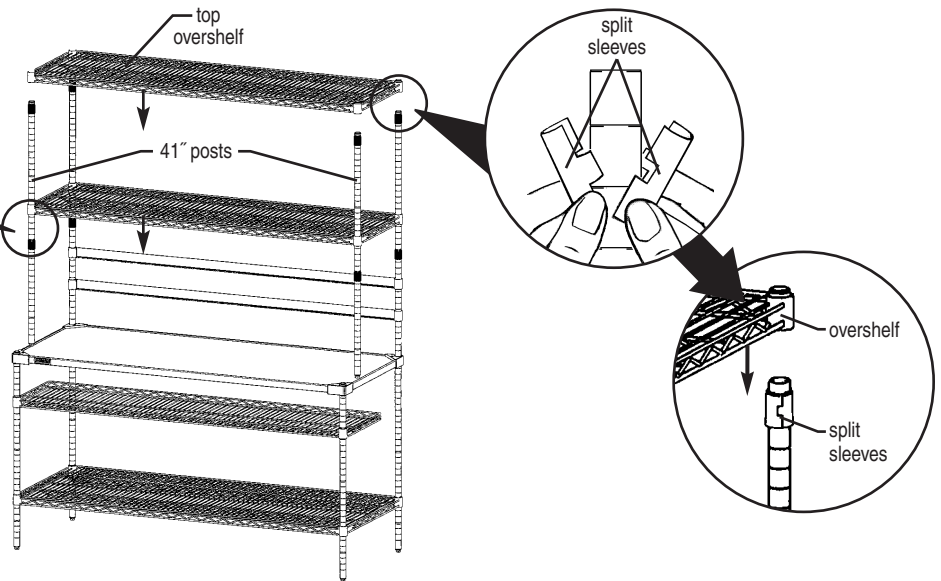

(continued on back page)

# Drive-Through Task Workstation

## ASSEMBLY INSTRUCTIONS

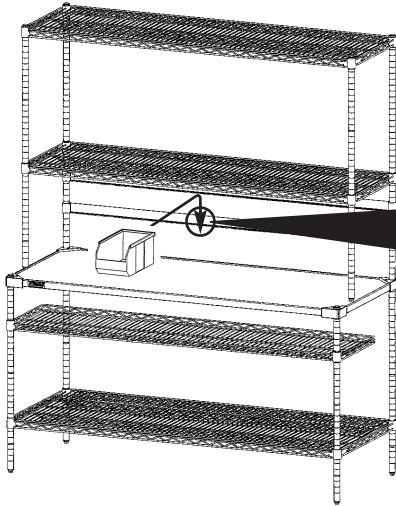

### Step 8 - Attach supply bins onto hanger rails.

Hook rear of bin onto hanger rail at desired location.

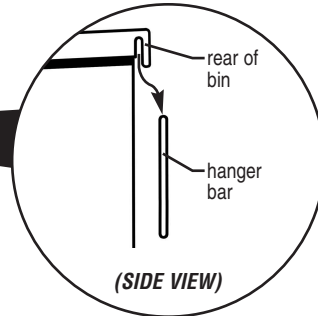

Repeat Step 8 to attach more bins as needed.

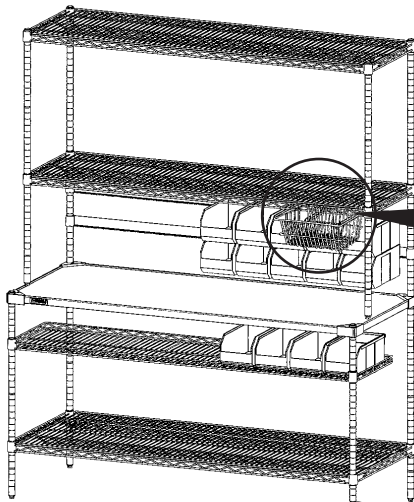

### Step 9 - Attach wire basket onto bottom overshelf.

Hook rear of basket onto front of bottom overshelf.

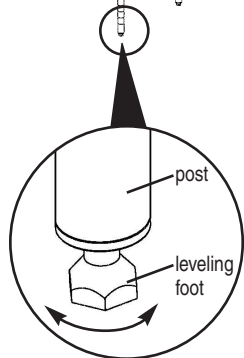
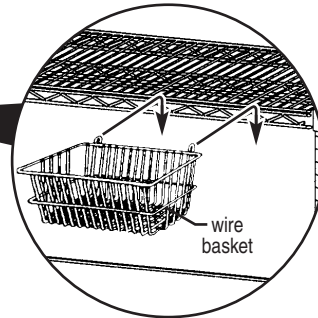

### Step 10 - Level unit.

The leveling feet allow approximately 1" adjustment.

Assembly is complete.

(End)