

Style "A" Tank Rack**ASSEMBLY INSTRUCTIONS**

For assembly of style "B" tank rack, see reverse page.

CAUTION

INSPECT CONTENTS IMMEDIATELY AND FILE CLAIM WITH DELIVERING CARRIER FOR ANY DAMAGE.
SAVE YOUR BOX AND ALL PACKING MATERIALS.
 YOU ARE RESPONSIBLE FOR DAMAGE TO YOUR UNIT IF RETURNED IMPROPERLY PACKED.

Step 1 - Attach four-sided frame to posts.

Snap split sleeves onto posts at desired height.

- The wider part of the taper goes toward the bottom.
- Make sure rib on split sleeve is seated into a groove on the post.

Note: For an NSF installation, this must be mounted at the 5th groove or above.

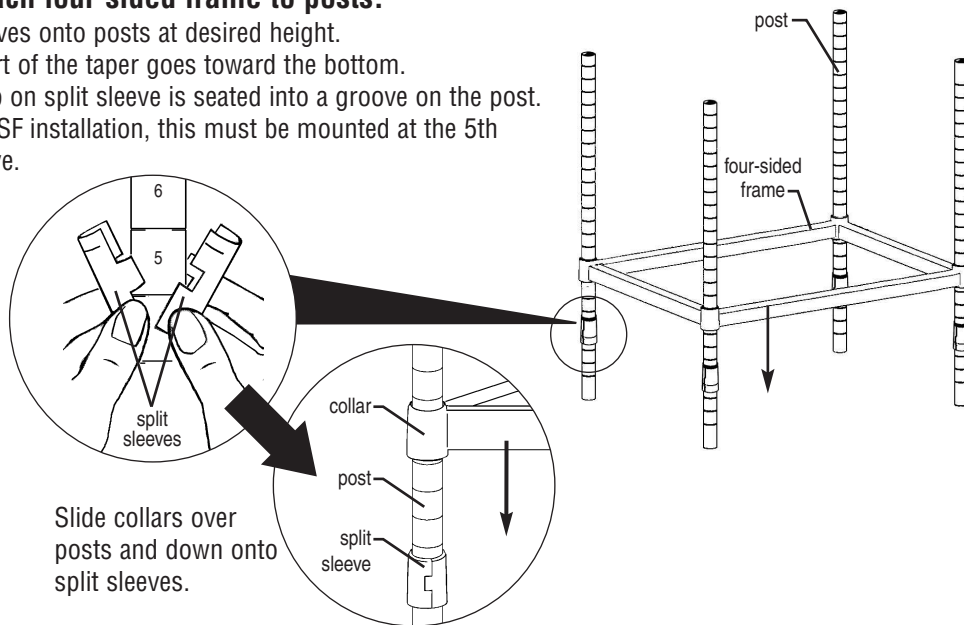

Slide collars over posts and down onto split sleeves.

Step 2 - Attach three-sided frame to posts.

Note: Attach cable assembly BEFORE mounting three-sided frame.

Snap split sleeves onto top groove of posts.

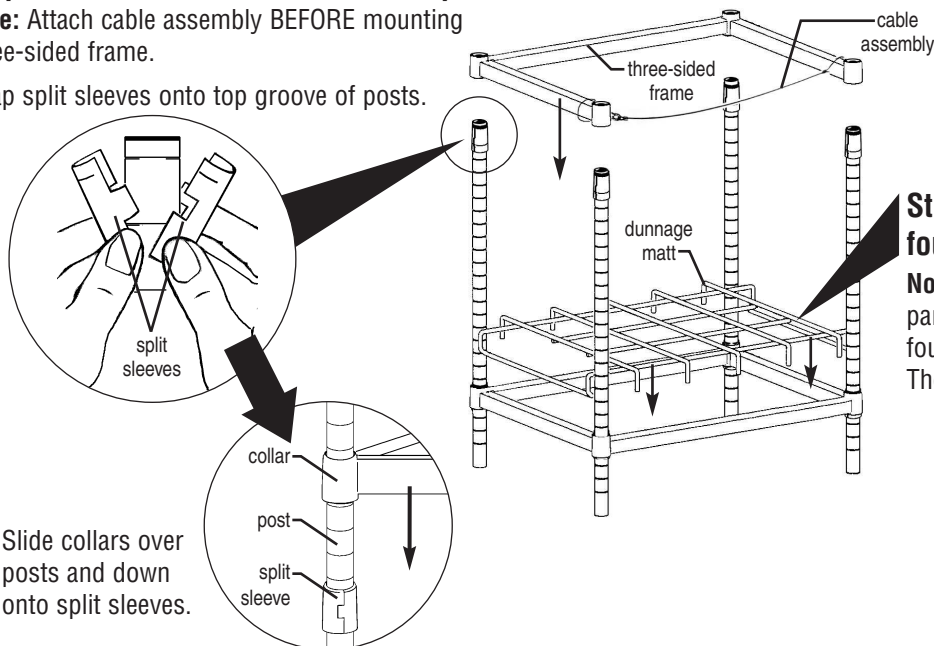

Slide collars over posts and down onto split sleeves.

Step 3 - Mount dunnage matt onto four-sided frame.

Note: If optional drip pan is being used, the drip pan mounting brackets must be placed on the four-sided frame BEFORE placing the wire matt. The pan slides between the mounting brackets.

(End)

Style "A" Tank Rack

ASSEMBLY INSTRUCTIONS

Step 1 - Attach four-sided frame to posts.

Snap split sleeves onto posts at desired height.

- The wider part of the taper goes toward the bottom.
- Make sure rib on split sleeve is seated into a groove on the post.

Note: For an NSF installation, this must be mounted at the 5th groove or above.

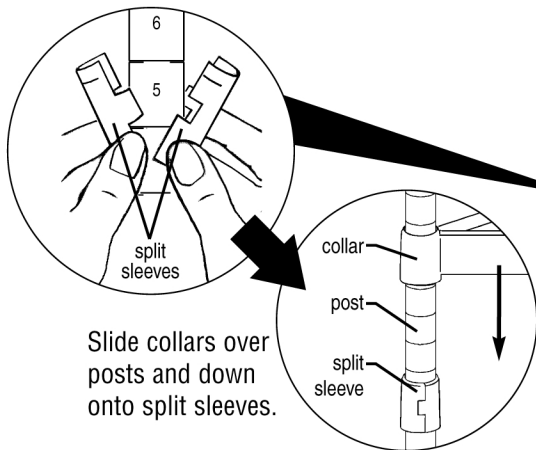

Step 2 - Attach three-sided frame to posts.

Note: Attach cable assembly BEFORE mounting three-sided frame.

Snap split sleeves onto or near #33 groove of posts. (Height may vary per application.)

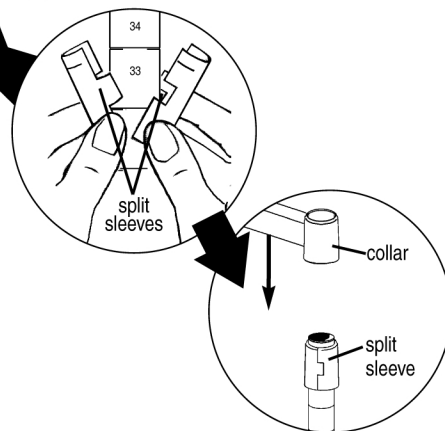

Step 3 - Attach bottommost wire shelf.

Snap split sleeves onto or near #54 groove of posts. (Height may vary per application.)

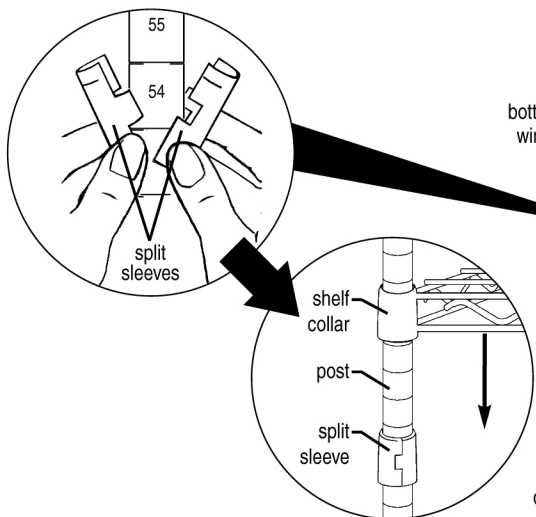

Step 4 - Attach top wire shelf.

Snap split sleeves onto top groove of posts.

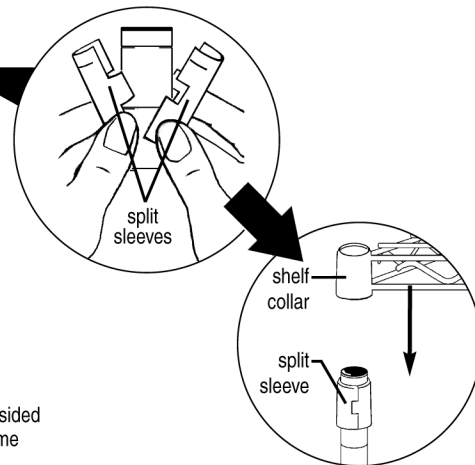

Step 5 - Mount dunnage matt onto four-sided frame.

Note: If optional drip pan is being used, the drip pan mounting brackets must be placed on the four-sided frame BEFORE placing the wire matt. The pan slides between the mounting brackets.

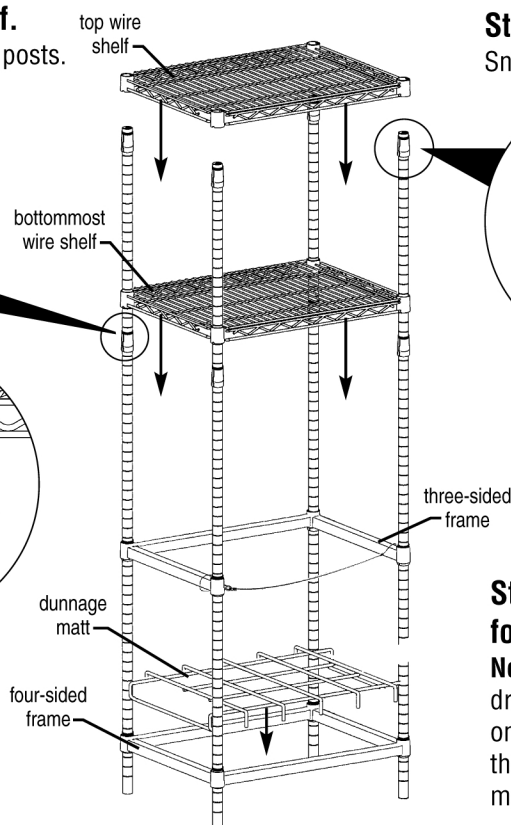

(End)



Profit from the Eagle Advantage®

• 100 Industrial Boulevard, Clayton, Delaware 19938-8903 U.S.A. • www.eaglegrp.com
• Phone: 302/653-3000 • (Foodservice) 800/441-8440 • (MHC/Retail) 800/637-5100
• Fax: 302/653-2065

Eagle Foodservice Equipment, Eagle MHC, SpecFAB, and Retail Display are divisions of Eagle Group. ©2007 by the Eagle Group