

ASSEMBLY INSTRUCTIONS

CAUTION

INSPECT CONTENTS IMMEDIATELY AND FILE CLAIM WITH DELIVERING CARRIER FOR ANY DAMAGE. **SAVE YOUR BOX AND ALL PACKING MATERIALS.** YOU ARE RESPONSIBLE FOR DAMAGE TO YOUR UNIT IF RETURNED IMPROPERLY PACKED.

Parts List

<i>part#</i>	<i>description</i>
PLASTIC SPLIT SLEEVES . . .	split sleeves
303999	bolts
300964	lock washer

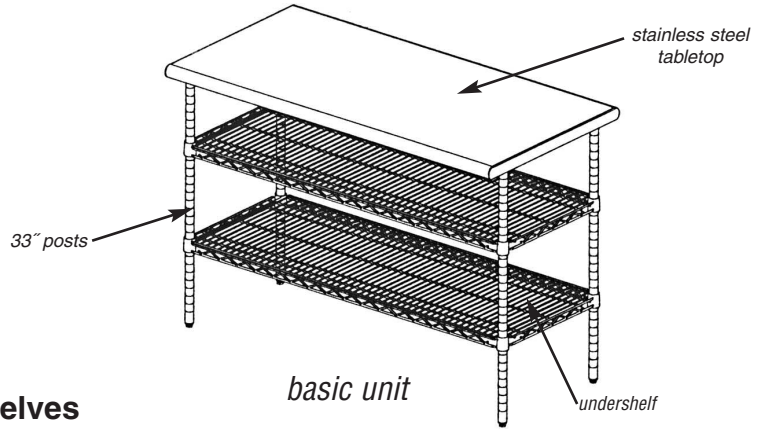

Configurations of Optional Overshelves

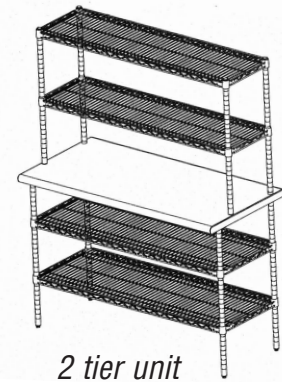
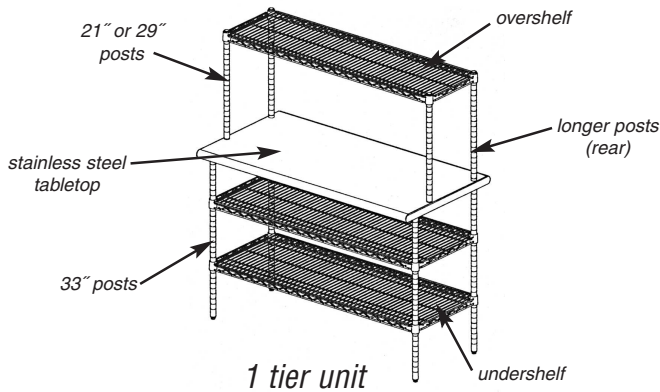

Configurations of Optional Cantilevered System

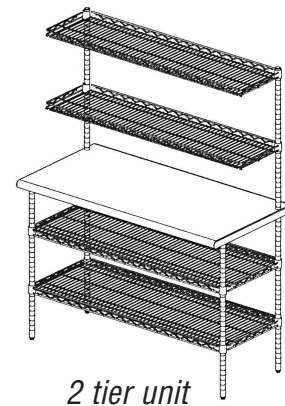
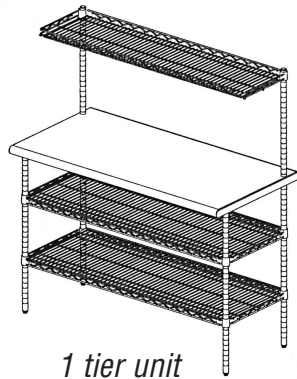

Note: Alternative base configurations not shown.

- Base with two C-frames
- Base with C-frame and one wire undershelf
- Base with two H-frames
- Base with H-frame and one wire undershelf

ASSEMBLY INSTRUCTIONS

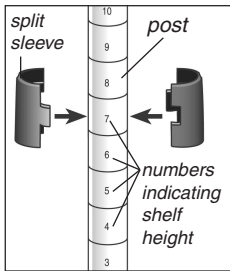

figure 1

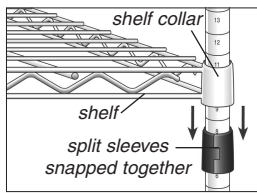

figure 2

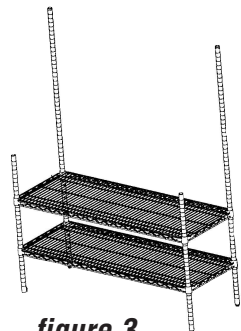

figure 3

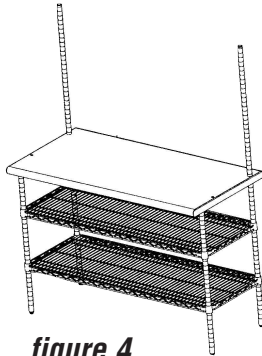

figure 4

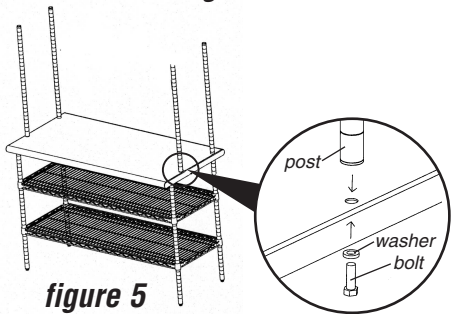

figure 5

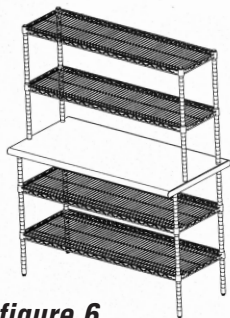

figure 6

1

Undershelves

Referencing numbers on posts, snap plastic tapered split sleeves onto each post (two longest posts go in the back and two 33" in the front) at desired location of undershelf. The thicker part of the taper goes toward the bottom. Refer to **figures 1 and 2**. Make sure rib on split sleeve is seated into a groove on the post. Lower the shelf onto the posts until the plastic tapered split sleeves are snugly fitted within the shelf collars. Repeat this step for second undershelf. Refer to **figure 3**.

Note: The wider wire shelves are the undershelves. The narrow wire shelves are the overshelves.

2

Stainless Steel Tabletop

Snap the plastic tapered split sleeves onto the very top of the shorter posts. Be sure that the plastic tapered split sleeves get snapped to the same groove on the longer posts. Lower the tabletop over the longer posts until the tabletop is seated snugly on the split sleeves. Refer to **figure 4**.

For units with overshelves continue with steps 3 and 4.

3

Units with Overshelves

Bolt the two 21" or 29" posts onto the table top. One end of these posts has a nut welded in it. This is the end for the bolt. Refer to **figure 5**.

4

Overshelves

Referencing numbers on posts, snap plastic tapered split sleeves onto each post at desired location of overshelf. The thicker part of the taper goes toward the bottom. Make sure rib on split sleeve is seated into a groove on the post. Lower the shelf onto the posts until the plastic tapered split sleeves are snugly fitted within the shelf collars. Repeat this step for second overshelf. Refer to **figure 6**.

5

Seat Shelves

Securely seat all shelves by lightly tapping with a rubber mallet to secure shelving to split sleeve and post.

Note: Follow similar steps outlined per purchase configuration options.