

Wall-Mounted Boat Racks

(Models #BRW4, BRW5, and BRW6)

ASSEMBLY INSTRUCTIONS

For models #BRW7 and BRW8, see inside.

Parts List

#	qty	part #	description
#1	2	*	wire shelf
#2	*	R26-C	rod & tie
#3	8	n/a	collar plug
#4	*	A204297	clip hold down for rods
#5	2	PW33C**	33" posts

* Quantities and/or part numbers vary, depending on what is ordered.
 ** Please note that the following parts are included with part #PW33C:

#	qty	part #	description
#6	4	A217323	top/bottom support
#7	4	303999	bolt 3/8-16 x 1 1/4"
#8	4	PWB14C	post-wall bracket

Centerline Chart

Shelf Length	Centerline
48"	46 1/16"
60"	58 1/16"
72"	70 1/16"

1 Center Lines

Refer to chart at left to determine proper centerline distances between top/bottom supports and shelf brackets.

2 Top & Bottom Supports

- Mark bottom support location at desired height (see *figure 1*) —using a level to insure support is level—and then screw* bottom support into wall.
- To determine top support location, bolt the post to the bottom support on the wall, then bolt the top support to the post (see *figure 2*). IMPORTANT: Use a level to insure post is straight.
- Mark top support location. Disassemble the post and supports. Screw* top support into wall (see *figure 1*).
- Based on "Centerline Chart", measure and mark locations of the other pair of supports, and then screw* supports into wall.

* Screws not included for top/bottom supports.

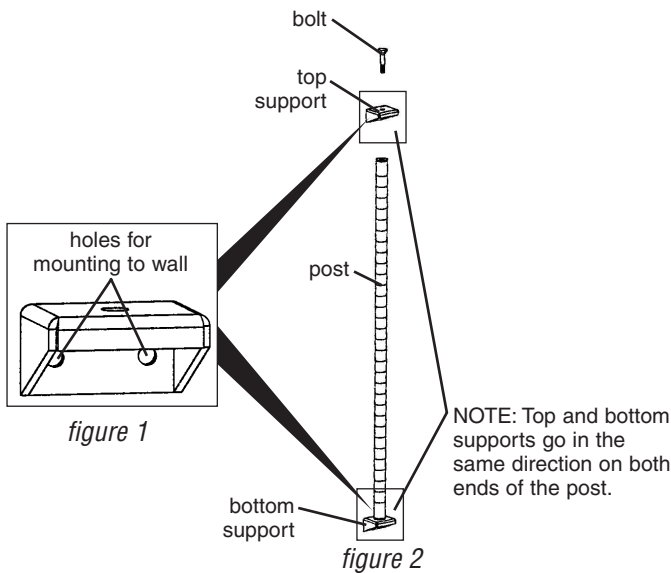

(continued inside)

Wall-Mounted Boat Racks

(Models #BRW4, BRW5, and BRW6 – continued)

ASSEMBLY INSTRUCTIONS

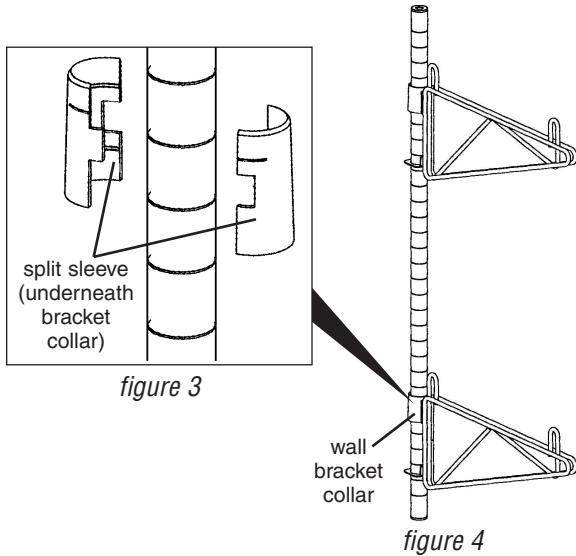

3 Shelf Brackets

- Snap plastic split sleeve onto post at desired shelf height (the wider part of the taper on the split sleeve is the bottom - see *figure 3*). Leave enough room at the bottom of the post for the wall bracket to hang.
- Slide wall bracket collar (see *figure 4*) over top of post and down onto plastic split sleeve. Repeat for each bracket.

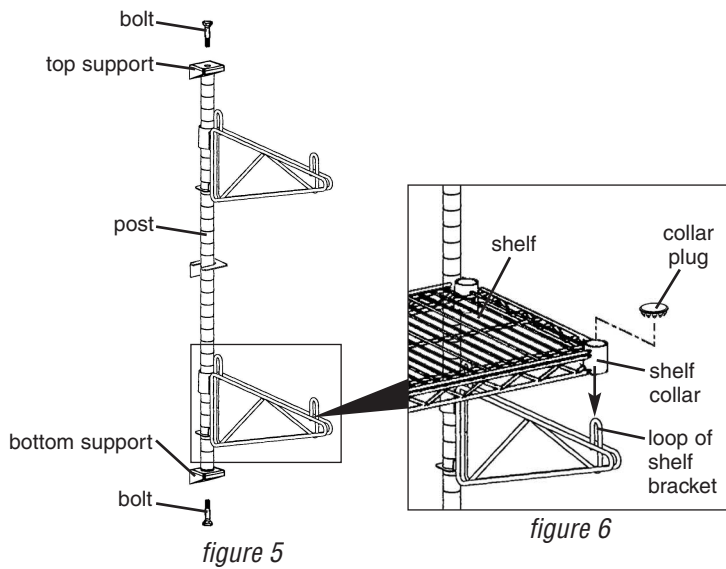

4 Posts & Shelves

- Bolt the posts to the supports that are already attached to the wall (see *figure 5*).
- Lay shelf (shelves) on top of wall bracket(s), and cover shelf collar openings with collar plugs (see *figure 6*).

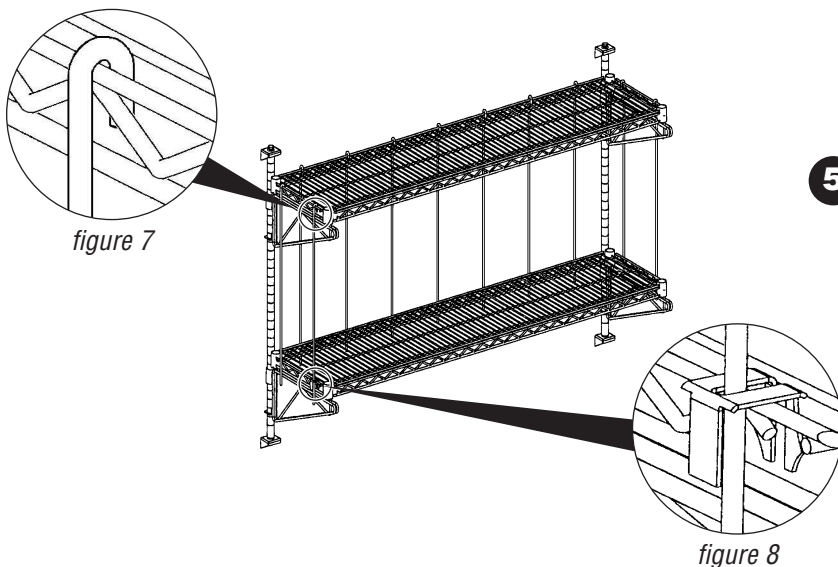

5 Rods & Tabs

- Hook the rods where desired onto the outside of the top shelf (see *figure 7*).
- Clip the rods to the bottom shelf with the clips provided (see *figure 8*).

(End)

Wall-Mounted Boat Racks

(Models #BRW7 and BRW8)

ASSEMBLY INSTRUCTIONS

Parts List

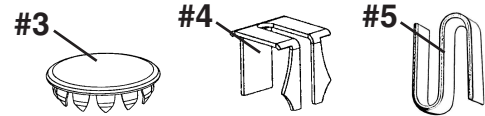

#	qty	part #	description
#1	4	*	wire shelf
#2	*	R26-C	rod & tie
#3	16	n/a	collar plug
#4	*	A204297	clip hold down for rods
#5	4	A200012	S-hooks
#6	3	PW33C**	33" posts
* Quantities and/or part numbers vary, depending on what is ordered.			
** Please note that the following parts are included with part #PW33C:			
#	qty	part #	description
#7	6	A217323	top/bottom support
#8	6	303999	bolt 3/8-16 x 1 1/4"
#9	6	PWB14C	post-wall bracket

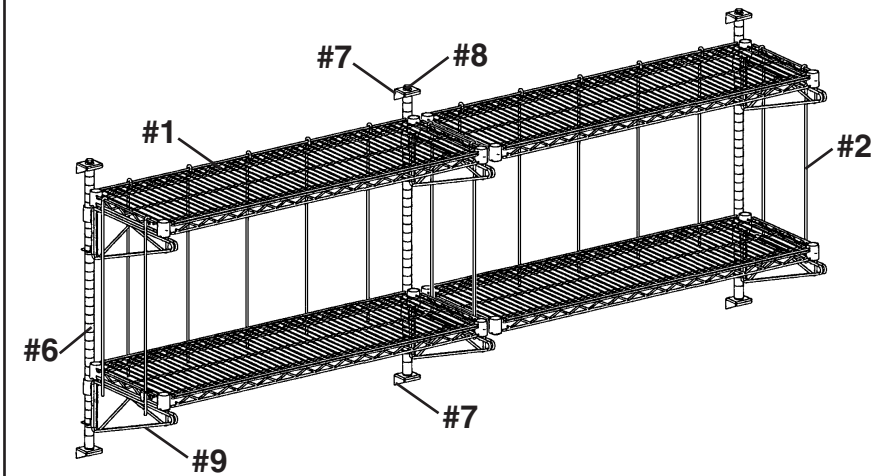

Centerline Chart

Shelf Length	1st Centerline	2nd Centerline
84"	.40 ⁷ / ₁₆ "	.82 ³ / ₁₆ "
96"	.46 ⁷ / ₁₆ "	.94 ³ / ₁₆ "

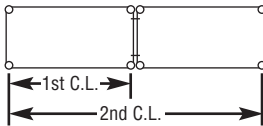

1 Center Lines

Refer to chart at left to determine proper centerline distances between top/bottom supports and shelf brackets.

2 Top & Bottom Supports

- Mark bottom support location at desired height (see *figure 1*)—using a level to insure support is level—and then screw* bottom support into wall.
- To determine top support location, bolt the post to the bottom support on the wall, then bolt the top support to the post (see *figure 2*). IMPORTANT: Use a level to insure post is straight.
- Mark top support location. Disassemble the post and supports. Screw* top support into wall (see *figure 1*).
- Based on "Centerline Chart", measure and mark locations of other two pairs of top/bottom supports, and then screw* top/bottom supports into wall.

* Screws not included for top/bottom supports.

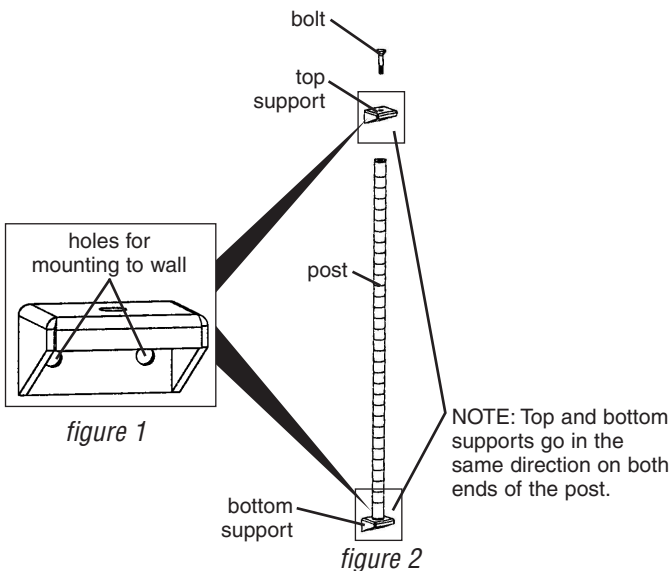

(continued on back page)

Wall-Mounted Boat Racks

(Models #BRW7 and BRW8 - continued)

ASSEMBLY INSTRUCTIONS

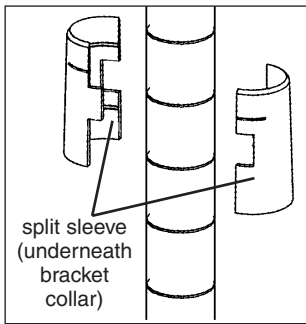

figure 3

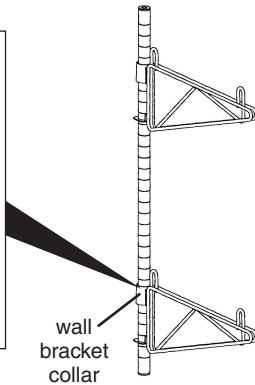

figure 4

3 Shelf Brackets

- Snap plastic split sleeve onto post at desired shelf height (the wider part of the taper on the split sleeve is the bottom - see *figure 3*). Leave enough room at the bottom of the post for the wall bracket to hang.
- Slide wall bracket collar (see *figure 4*) over top of post and down onto plastic split sleeve. Repeat for each bracket.

Repeat this step for remaining posts and brackets.

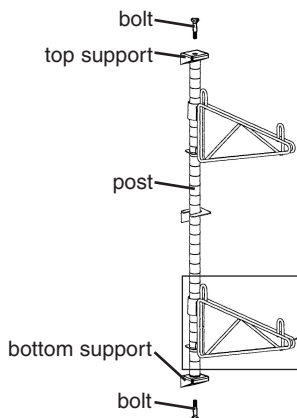

figure 5

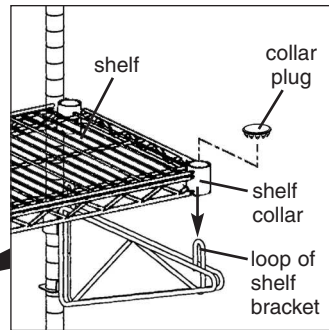

figure 6

4 Posts & Shelves

- Bolt the posts to the supports that are already attached to the wall (see *figure 5*).
- Lay each shelf on top of wall brackets, and cover shelf collar openings with collar plugs (see *figure 6*).

5 S hooks

- Hook two S-hooks onto the outside of the top shelf (see *figure 7*).
 - Lay adjoining shelf inside S-hooks (see *figure 7*).
- Repeat this step for remaining shelf.

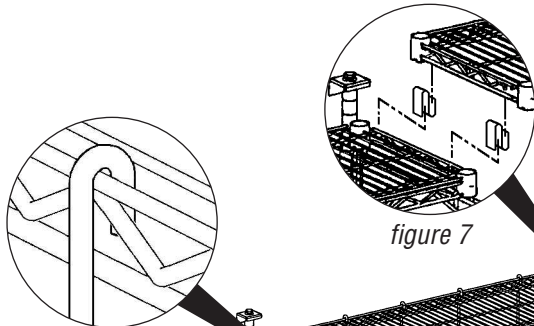

figure 7

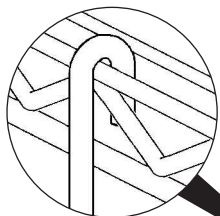

figure 8

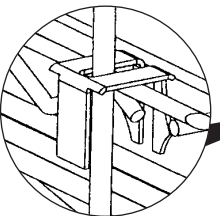

figure 9

6 Rods & Tabs

- Hook the rods where desired onto the outside of the top shelf (see *figure 8*).
- Clip the rods to the bottom shelf with the clips provided (see *figure 9*).

(End)

EAGLE
GROUP[®]
Profit from the Eagle Advantage[®]

• 100 Industrial Boulevard, Clayton, Delaware 19938-8903 U.S.A. • www.eaglegrp.com
• Phone: 302/653-3000 • (Foodservice) 800/441-8440 • (MHC/Retail) 800/637-5100
• Fax: 302/653-2065 or 302/653-3036