

Modular Bag-n-Box

ASSEMBLY INSTRUCTIONS

CAUTION

INSPECT CONTENTS IMMEDIATELY AND FILE CLAIM WITH DELIVERING CARRIER FOR ANY DAMAGE.
SAVE YOUR BOX AND ALL PACKING MATERIALS.
 YOU ARE RESPONSIBLE FOR DAMAGE TO YOUR UNIT IF RETURNED IMPROPERLY PACKED.

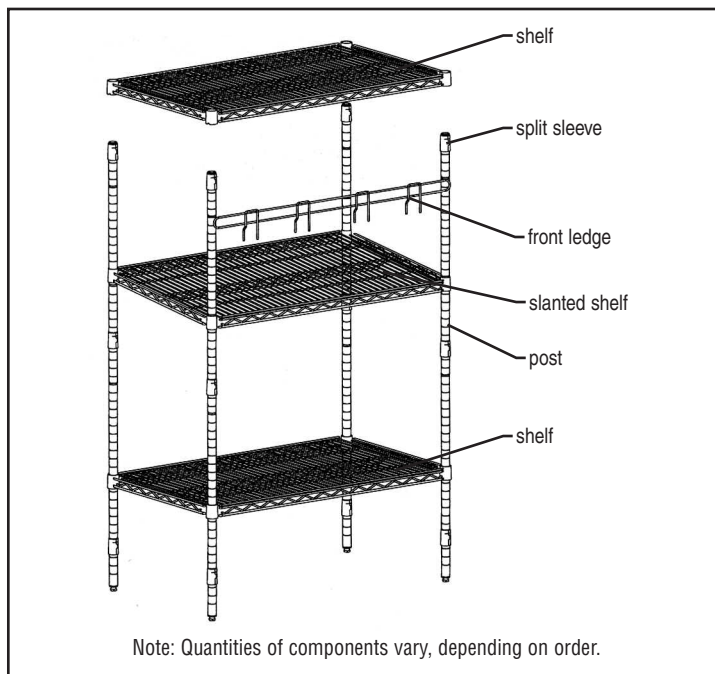

Step 1 - Attach split sleeves (for bottom shelf) to posts.

Note: the wider part of the taper goes toward the bottom.

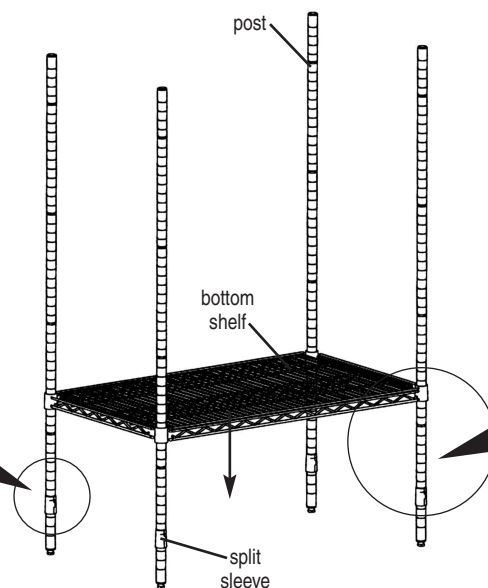
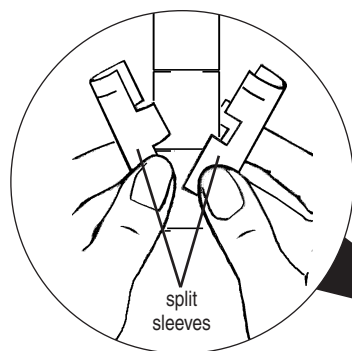

Step 2 - Assemble bottom shelf.

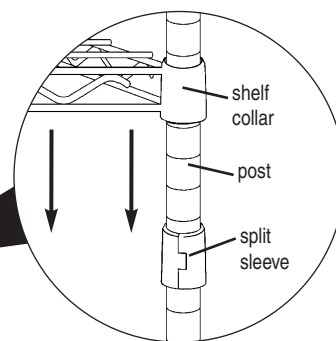

(continued on back page)

EG9977 Revised 04/05

Modular Bag-n-Box

ASSEMBLY INSTRUCTIONS

Step 3 - Assemble slanted shelf.

Note: Assemble the rear split sleeves 2 grooves higher than the front split sleeves.

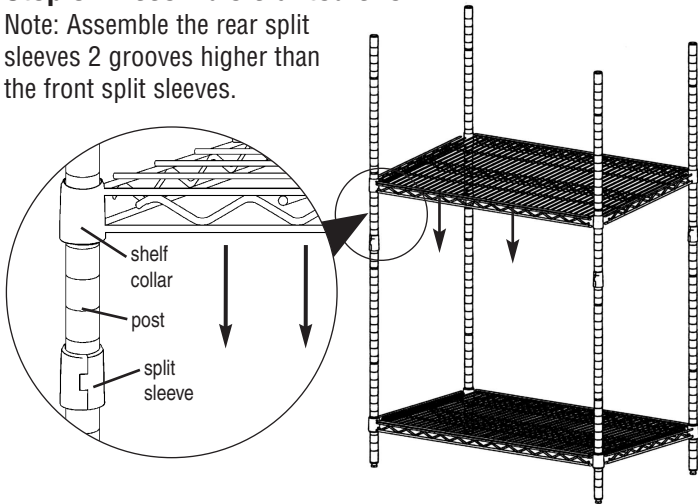

Step 4 - Add front ledge to the slanted shelf.

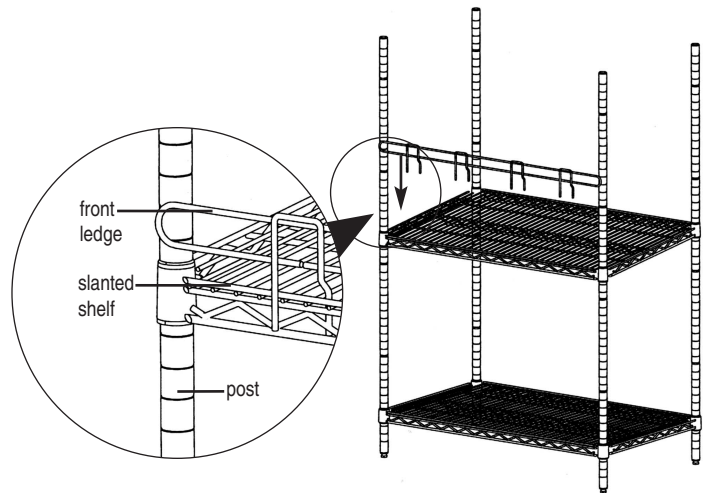

Step 5 - Assemble top shelf.

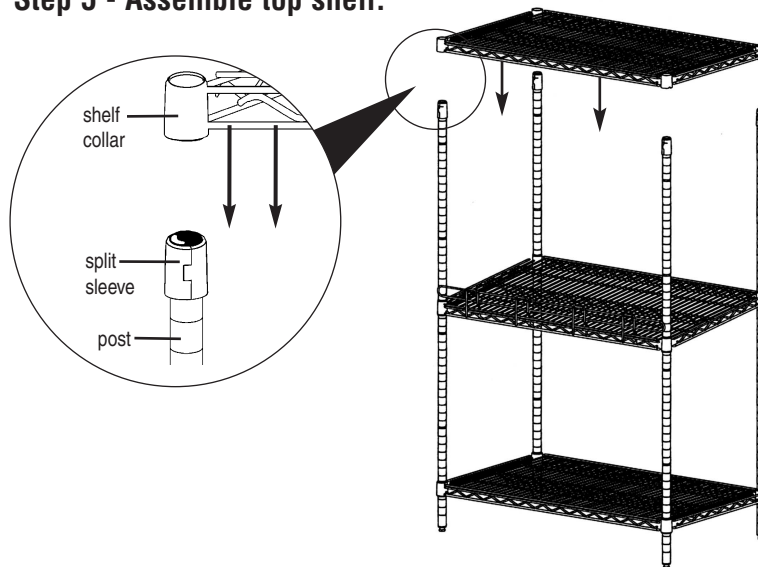

(End)