



### Ice Machine Models

- E-UCF160
- E-UCH160
- E-UCF210
- E-UCH210
- E-UCH280
- E-UCF310
- E-UCH310

*Please read this manual completely before attempting to install or operate this equipment. Notify carrier of damage! Inspect all components immediately.*

## CONTENTS

■ Safety Warnings .....	3
■ Features, Size & Appearance .....	4
■ Unpacking, Installation & Water Supply .....	5
■ Drainage, Power, Cleaning & Check .....	6
■ Operation .....	7
■ Ice Making Workflow & Inspection .....	8
■ Routine Cleaning .....	9-11
■ Ceaning & Disinfection .....	12
■ Cleaning Process .....	13
■ Disinfection Process .....	14
■ Parts Removal / Installation Process.....	15
■ Winterization / Deactivation .....	16
■ Maintenance .....	17
■ Circuit Diagram .....	18
■ Structural Explosive View .....	19
■ Refrigeration & Water System Diagram .....	20
■ Electrical Control System .....	21

When you operate and maintain the ice machine, please be sure to pay attention to the safety instructions in the manual. Ignoring these tips may cause personal injury and damage to the ice machine.

In this manual, you will see safety prompts in the following form:

### **! Warning**

Potential personal injury. Failure to install, use, or use a machine that has been modified without authorization may cause personal injury.

### **▲ Notice**

The correct installation, usage and maintenance of the ice maker is very important to the output of the ice maker and reduce the failure rate. Please read and understand this manual, which contains valuable information on installation, usage and maintenance. If you encounter problems not covered in this manual, you may contact our company or our service provider at any time.

### **★ Important**

The adjustment, maintenance and cleaning contents in this manual are not covered by the warranty.

Please keep this manual well

The instruction manual is an inseparable and important part of this product, and the user should keep it properly. Please be sure to read the warnings, cautions and important matters described in this manual carefully, because these warnings, cautions and important matters provide installers/users with important information needed for proper installation, continuous and safe use and maintenance of this product. Please keep this manual properly for reference when necessary.

### 1. Features

- UC Series ice maker has a number of patented control systems, simple operation and precise control, suitable for different water quality conditions; ;
- The key components are all internationally renowned brands to ensure reliable work in harsh environments ;
- The parts in contact with water are made of food-grade plastic material, and the shell is made of stainless steel to ensure food safety and excellent rust resistance.

### 2. Size and Appearance

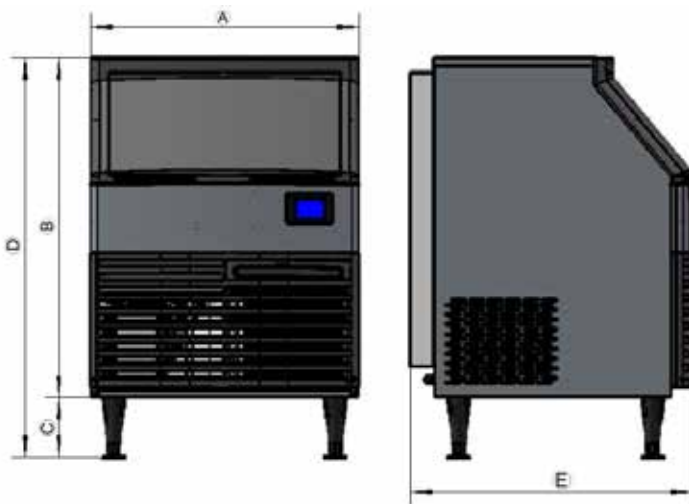

#### ● Size list of ice maker (unit: cm)

	A	B	C	D	E
E-UCF160	66	84	16	100	70
E-UCH160	66	84	16	100	70
E-UCF210	66	84	16	100	70
E-UCH210	66	84	16	100	70
E-UCF280	66	84	16	100	70
E-UCH280	66	84	16	100	70
E-UCF310	66	84	16	100	70
E-UCH310	66	84	16	100	70

#### ● Appearance



- ① Door
- ② Decorative plates
- ③ Ventilation window
- ④ Top cover
- ⑤ Display screen
- ⑥ Right Plate
- ⑦ Height Adjustable Foot

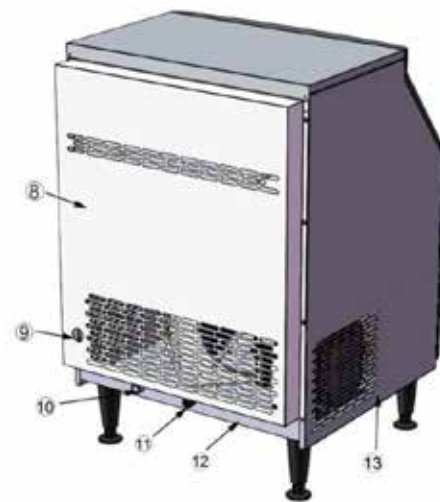

- ⑧ Rear Plate
- ⑨ Drain hole
- ⑩ Inlet valve
- ⑪ Power cord connector
- ⑫ Bottom plate
- ⑬ . Left late

### 3. Unpacking

- Before unpacking, check whether the anti-tilting signs (if any) are intact, whether the outer packaging of the machine is intact, and whether the model of the machine is consistent with your purchase
- Open the package to check whether the appearance of the machine is in good condition, take out the accessories and random documents, and check whether it matches the packing list;
- Remove the protective film on the shell (recommended).
- If there is any discrepancy or damage, please contact our company/dealer directly.

### 4. Installation location

#### **! Warning**

**The installation of the ice machine should comply with safety standards, and the ice machine should not be installed in the aisles of public buildings.**

- This ice machine is not suitable for outdoor use, Do not install it near a heat source or direct sunlight ;
- The normal working environment temperature is 10C° ~ 38C°, and the water temperature is 5C° ~ 32C°. If the ice maker works outside the above normal temperature range for a long time, it may affect the ice making capacity ;
- The ice maker should be installed on a solid, flat ground ;
- The ice maker should be placed close to the source of drinking water, and it is recommended to be within one meter of the ice maker ;
- Do not block the ventilation windows of the ice machine, and there should be enough air convection space around the ice machine ;
- The ice machine cannot work at sub-zero temperatures. In order to prevent the water

supply pipeline from malfunctioning, when the temperature is below zero, please drain the water in the ice maker (see "Preparations for long-term storage of the ice maker").

### 5. Level Adjustment

#### **▲ Note**

**When adjusting the level of the ice machine, do not use the method of putting hard objects under the feet to adjust the level. It is necessary to ensure that the four feet of the ice maker are in stable contact with the ground to prevent the machine from vibration.**

- Screw the adjustable parts of the 4 adjusting feet to the end, and then rotate the adjusting feet into the corresponding mounting holes at the four corners of the bottom plate of the ice machine ; ;
- Move the ice maker to the installation location. Use a spirit level to level the ice maker.

### 6. Water supply/Drainage

#### 6.1 Water Supply

#### **! Warning**

**The ice maker must be connected to a source of potable water**

- According to the local water supply, determine whether it is necessary to install a water treatment system to prevent the formation of sediments, filter out impurities, and remove the smell of bleaching powder ;
- Please follow the guidelines below to install the water supply pipe :
  - Do not connect the ice maker to a hot water source ;

- If the water pressure exceeds the maximum allowable water inlet pressure (1~5bar), please purchase a water pressure regulating valve ;
- A manual water supply valve must be installed before all water supply pipes of the ice machine.

### 6.2 Drainage

- When installing the drain pipe, to prevent water from flowing into the ice machine bin, please follow the following guidelines :
- The main drainage pipe should be able to drain the water in all drainage branches ;
  - The drain pipe of the storage refrigerator should be covered with insulation material to prevent condensation ;
  - The drain pipe of the water-cooled condenser and the drain pipe of the storage refrigerator should be placed separately;
  - Every additional meter of drain pipe must have a drop of 2.5 cm and no bends.

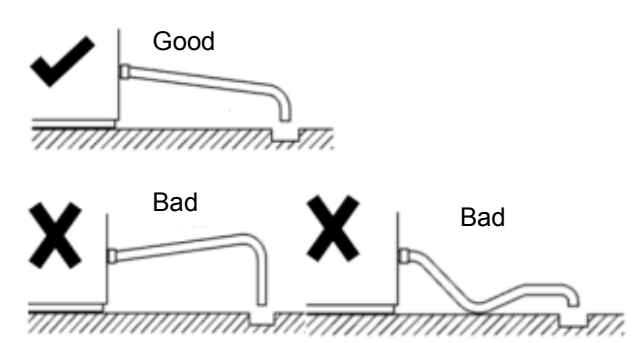

### 7. Power supply

- The power supply voltage, frequency and power supply capacity must be consistent with those marked on the machine nameplate ;
- Allowable voltage fluctuation range is  $\pm 10\%$  of rated voltage ;

### ! Warning

**The power supply must be grounded reliably, and the wiring used must comply with the laws and regulations of the country and region where the ice machine is used.**

- The ice machine must be equipped with a circuit breaker separately.

### 8. Cleaning After Installation

After the ice maker is installed, clean the shell, inner container and ice shovel of the ice maker with a clean damp cloth/sponge;

### 9. Check After Installation

### ! Warning

**Banana water, oxalic acid, hydrochloric acid and other corrosive detergents are strictly prohibited.**

After the ice maker is installed, check the following contents before running

- Is the ice machine even?
- Have all the inner packaging been removed? ?
- Are all the water and electricity connected? ?
- Does the supply voltage match the rated voltage on the nameplate? ?
- Is the ice machine properly grounded? ?
- Is there a proper space around the ice machine for air circulation ?
- Is the ambient temperature of the ice maker between 10°C and 38°C? ?
- Is the inlet water temperature at the installation point of the ice maker maintained between 5°C and 32°C? ?
- Are the ice machine and refrigerator clean?



## 10. Operation

### 10.1 Power on/off

- **Power on :** Connect water supply and drainage, plug in power plug, press power switch, touch screen start to light up;

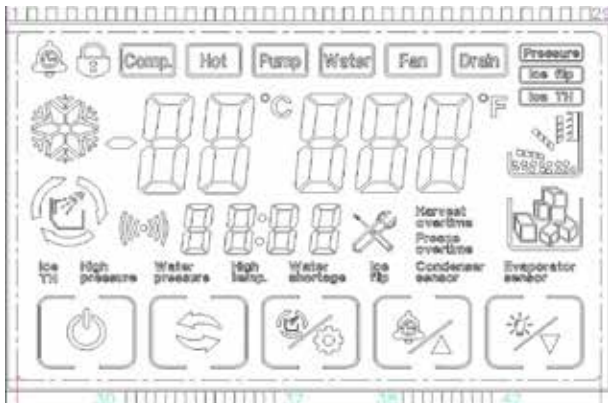

- **Power off:** In ice making, press " " once, the ice maker stops making ice (standby state), the screen shows "OFF", press the power switch, then pull out the power plug.

### 10.2 Ice making

a. After the ice maker is power on, the ice maker automatically enters the ice making preparation work. The preparation process includes water pump start, hot valve open, compressor start, fan start, etc. Under normal circumstances, after the preparation work is finished, the ice maker start automatic ice making, no need to do any more operation until the ice machine stops making ice; when the ice is removed, the ice machine begins to make ice;

- b. In standby state, press " " once, start making ice.

#### ▲ Notice

The ice maker has been tested and debugged in the factory before shipment. The new machine can make ice without any debugging.

### 10.3 Ice Thickness Adjustment

- In the ice-making state, press " " or " " "can see the screen" " count display number start flashing, each press " "can increase the ice-making time for 1 minute, each press" " can reduce the ice-making time for 1 minute; after adjustment, stop operation, " " the number no longer flashes, the ice thickness setting is complete (note: before and after the ice thickness adjustment, the ice maker has been making ice);

### 10.4 Forced de-icing

- Press " "to force deicing under ice-making condition;

### 10.5 Manual cleaning





- Press " "in standby state, enter manual cleaning state, cleaning icon flicker, water inlet valve open, screen display start timing, about 15 minutes later, cleaning stop, start drainage,30 s after drainage, enter automatic rinsing stage, Clean for 3 minutes, drain for 30 s, and recycle for 5 times, the whole cleaning process and the screen shows "OFF", enter standby state;

**Note:** if you need quick cleaning, you can not wait 15 minutes to start drainage directly after 30 s, enter the rinsing stage, rinse if you do not need to cycle many times can press " "stop rinsing, into standby state;

### 10.6 Reserve ice making

- Standby state (display "OFF"), the first time press " " enter time settings, each press " "can increase 10 minutes, each press" " can reduce 10 minutes; after setting up, press " "once, the screen shows the countdown of the set time, When the countdown is 00:00, the ice maker begins to make ice.

### 10.7 Set up function

- Standby state (screen display OFF), long press "  "until the screen " OFF "disappear jump into the parameter setting state, "  "through "  ", to control the addition and subtraction operation, set the state of light point"  " switch the next setting, parameter switch round, from the first parameter cycle again.

\*" Setup function "is recommended to be operated under the guidance of professionals and not to be adjusted privately (see maintenance page for page 14);

## 11. Ice-Making Workflow

**11.1.**The display is all on after power-on, and all off after 1 second. Then enter the power-on balance state. The hot valve opens, and the water valve and fan are controlled. After 30 seconds, the press opens, and after another 5 seconds, the hot valve closes to start ice making.

**11.2.**During the ice making process. The compressor continues to open, the hot valve and the drain valve are closed, the fan is controlled, the water pump opens after 30 seconds, the water valve is controlled within the first 5 minutes, and it is forced to close after 5 minutes. When the time exceeds 23 minutes or it is detected that the water temperature is lower than 3°C, the set ice-making time will be delayed. When the delay time expires, the ice-making ends. If water is needed, open the drain valve 30 seconds before the end of ice making.

**11.3** After the ice making is over, it enters the deicing state. The compressor continues to open, the hot valve opens, the water valve is controlled, and the water pump, fan and drain valve are closed. The maximum time for deicing is limited to 6 minutes. If the ice does not come off in 5 minutes, turn on the water pump for 1 minute. If the ice is still not removed, switch to ice making. Three times in a row for more than 6 minutes, switch to de-icing overtime shutdown.

**11.4**After the ice is taken off, if the ice in the storage refrigerator is not full, it will enter the ice making state and start a new cycle. If the refrigerator is full of ice, it will enter the full ice-full shutdown state. The water pump, compressor, hot valve, water supply valve, fan and drain valve are all closed. If the ice is taken away, the ice full indicator will flash within 180 seconds after the ice is full. After the ice is full for 180 seconds, turn on the power and start a new cycle. If the ice is not taken away, it will always be full of ice.

## 12. Operation Inspection

- Make sure the water inlet tap is turned on
- Confirm that the water inlet valve has been opened
- The ice machine is powered on
- Check all water pipes and pipe joints to ensure that there are no leaks

### ▲ Notice

**The ice machine has been tested and debugged at the factory before shipment. Generally speaking, the newly installed machine does not need any debugging. In order to ensure the normal operation of the ice machine, an operation inspection is required under the following conditions ;**

- Initial start
- Restart after long downtime
- After cleaning and disinfection

## 13. Routine cleaning

**Clean environment:** clean the surroundings of the ice machine frequently to keep the environment clean and make the equipment operate efficiently.

**Shell cleaning:** Use a sponge dipped in neutral cleaning fluid to clean the ice machine and dry it with a clean soft cloth. Stainless steel cleaner can be used when necessary.

**Air filter cleaning:** The filter can filter out dirt or dust in the air and prevent the condenser from clogging. If the filter is clogged, the performance of the ice maker will decrease. It is recommended to clean the air filter once or twice a month :



### ▲ Notice

- It is strictly forbidden to flush the ice maker with a water jet. Do not use any alcohol-containing liquid to clean or disinfect the ice machine, otherwise it may cause cracks in the plastic parts ;
- Remove the top plate and back plate, but should be disassembled by maintenance personnel with appropriate knowledge ;
- Do not put plastic parts in water or dishwasher with a temperature of over 40C° to avoid damage to the parts.

### 13.1 Remove the top cover and back panel

- **Remove the top cover of the ice maker.** There are two screws on the top cover and the back of the ice maker. Use a Phillips screwdriver to remove them



Lift the top cover slightly upwards first, and then gently pull back to pull out the top cover

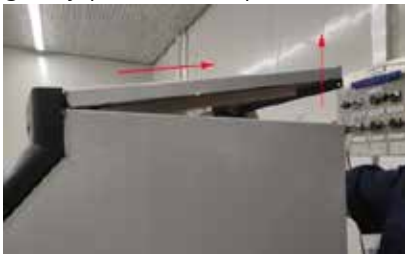

- remove the back plate of the ice machine. Use a Phillips screwdriver to remove the two screws on the upper part of the back plate. Lift the back plate upwards slightly to remove the back plate (Note: the drain pipe is placed on the back plate, gently pull Backboard, placement;

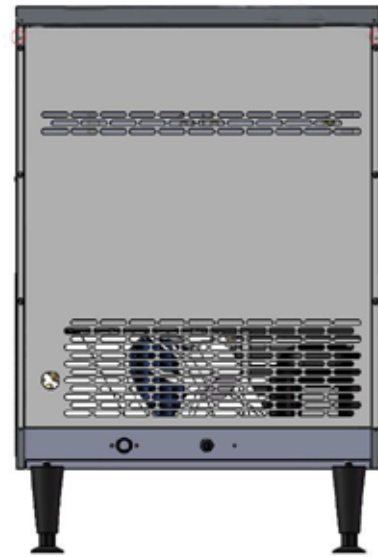

### ★ Important

If cleaning of some parts is necessary, it is not recommended to remove the top cover, please have the corresponding knowledge or under the guidance of professionals.

### 13.2. Evaporator cleaning

- Use a brush or sponge dipped in descaling agent or vinegar to scrub the surface of the evaporator;



Use nylon brush dipped in descaling agent or vinegar to scrub the plastic parts around

the evaporator;



### 13.3 Sink cleaning

Press the " " key to be in standby mode, the screen displays "OFF", unplug the power plug, use a screwdriver to remove the two screws on the water pump box, loosen the three screws on the inner wall of the ice storage bucket, remove the clamp, The connectors at the lower and upper water pipes, water pump and float can be removed and cleaned;

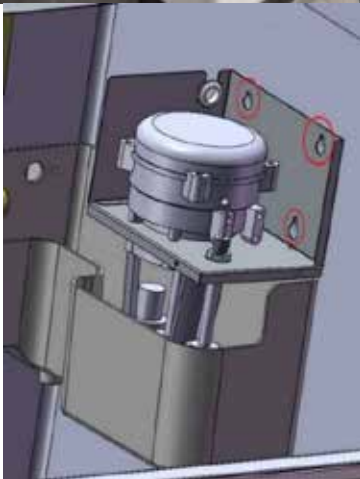

Use a soft material such as a brush or sponge dipped in descaling agent or vinegar to scrub the sink.



### ! Warning

To clean the condenser, the ice maker must be disconnected from the power supply. The edge of the condenser is sharp, so be careful of cuts when cleaning.

### ★ Important

Dirty condensers will block the air circulation, causing the ice maker to operate at an excessively high temperature, reducing ice production and shortening the service life of parts.

### 13.4 Condenser cleaning

It is recommended to clean the condenser every six months, and follow the steps below : Use Phillips screws to remove the screws on the left and right sides under the ventilation window and remove the ventilation window;



Pull the filter on the ventilation window upwards



Use a nylon brush to remove dust from the filter;



Brush the condenser fins up and down with nylon brushes to remove dust;



### ★Important

After cleaning, please reinstall the top cover and install it correctly. .

### 14. Cleaning and Disinfection

#### ▲ Notice

- Do not mix disinfectant and cleaning solution;
- Do not use sharp objects to clean the surface of the evaporator;
- It is recommended to perform this process once at least within 3 months.

#### ! Warning

- Before cleaning and disinfecting operations, please wear protective equipment such as rubber gloves, masks and protective glasses.
- Removal and installation of cleaned parts must be carried out under power-off conditions.
- Ice cubes during the cleaning and disinfection process must be discarded.

In order to make the operation of the ice machine stable and efficient, the user is responsible for operating in accordance with the requirements of cleaning and disinfection (the operation of cleaning and disinfection is not covered by the warranty). If the ice machine needs frequent cleaning and disinfection, please check whether the water source is suitable, whether the environment is clean or use an inappropriate water filter device.

#### 14.1 Cleaning process

1. Open the door of the ice maker and check if the ice maker evaporator is making ice. If ice is being made, the forced de-icing procedure can be executed (see the above operating instructions "10.4 Forced De-icing") to stop the ice making machine, press the  key to be in the standby state, the screen will display "OFF";



2. Take out all ice cubes in the refrigerator with an ice scoop ;

3. Press the  button, the ice maker enters the cleaning phase, the water inlet valve opens, and the screen displays the timing.



4. When water starts to flow on the evaporator,

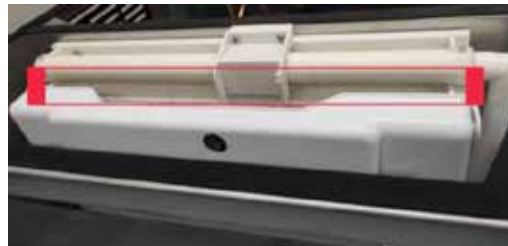

add 2 packs of cleaning agent (**KAY DELIMER, 56.7g/pack**) or mixed containing cleaning liquid, add them to the ice maker water tank



The water from the sink to the evaporator has been circulated for cleaning. After about 15 minutes, the



cleaning stops and starts to Fan.



Drainage is completed after 30s;



Enter the automatic rinsing phase, first clean for 3 minutes, then drain for 30 seconds. After the rinsing process is recirculated 5 times, the entire cleaning process ends and the screen displays "OFF".



Enter the standby state, the whole process takes about 37 minutes;

4. Unplug the power plug
5. Remove the water pipe, water baffle, take out the water pump, float ball, ice shovel (refer to the parts removal/installation process for the removal method)
6. Mix 8L heating water (45 ~ 50C°) and 4 packages of cleaning agent (KAY DELIMER, 56.7g/package) into a cleaning solution (the amount of cleaning solution needs to be adjusted appropriately for the amount of cleaning parts).
7. Soak the parts in the cleaning solution for more than 5 minutes (in the case of heavy scale, it is

recommended to soak for more than 10 minutes).



8. While soaking the parts, use a nylon brush or soft cloth dipped in cleaning fluid to wipe the surface of the parts that are in contact with water and ice, such as evaporator ice trays, ice shields, ice storage buckets, etc. The damp cloth wrapped disposable chopsticks to clean up). Then rinse with clean water (rinse 5 times).



Scrubbing the ice guard



Scrubbing the ice bin



Brush the water pipe core rod



Brush the bottom of the water pump



Brush the plastic parts around the evaporator



Brush evaporator



Brush water tank



Flush the evaporator



Rinse the sprinkler pipe and core rod

9. Take out the soaked parts and rinse them with clean water (rinse 5 times).

### 14.2 Disinfection process

1. Mix 8 warming water (45 ~ 50C°) and 2 packages of disinfectant (**KAY5, 28.4/package**) into a disinfectant (the amount of disinfectant is adjusted according to the amount of parts that need to be cleaned).

2. Soak the cleaned parts in the prepared disinfectant.





While soaking the parts, use a spray can to evenly and completely spray the disinfectant on the surface of the parts that are in contact with the ice, such as the evaporator ice tray, ice shield, ice storage bucket, etc. (the dead corners can be wetted with disinfectant Disposable chopsticks wrapped in a rag to clean)



After 20 minutes, take out the soaked parts and rinse the sterilized parts with clean water. Install the removed parts back to their original positions (**refer to 15.3 Parts removal/installation process for installation methods**) and perform this step strictly as required.

3. Use 1 liter of water and 1/2 package of disinfectant (**KAY5, 28.4/package**) to make a disinfectant.



4. Plug in the power plug, and then press the  key to put the ice maker in a standby state, the screen displays "OFF"; press the "

the screen displays "OFF"; press the "

the ice maker enters the cleaning phase, the water inlet valve opens, and the screen displays Start timing. When water starts to flow on the evaporator, add the disinfectant that has been prepared into the sink of the ice maker. At the same time, use a watering can with disinfectant to spray the outer surface of the tank to the evaporator. Minutes later, the cleaning stops and the drainage starts,



Flushing evaporator



5. Drainage is completed after 30s



6. Enter the automatic rinsing phase, first clean for 3 minutes, then drain for 30 seconds, after the tap water rinsing process cycle 2 times, and then rinse with pure water 3 times, the entire cleaning process ends, the screen displays "OFF", about 37 minutes later the entire cleaning process After the end, the screen displays "OFF", enter the standby state, and then unplug the power plug.

**7.Note:** Ice making starts after cleaning and disinfection. The first 5 plates of ice are discarded and do not eat.

### 14.3 Parts removal/installation process

a . When removing the water pipe, please remove the "pull out the "clamp" and the "up water pipe" (as shown in the picture)):

**Unplug the water pipe**



**Unplug the water pipe**



b . **Remove the two screws**



Unscrew the plastic cover and take out the plastic core rod



**Note:** When assembling the flow pipe, the hole position of the flow pipe must be opposite to the direction of the mandrel hole position, and the direction must not be the same.



■ Disassembly and assembly of the water baffle: grasp the middle position of the water baffle, use a flat-head screwdriver to apply force from one side to the other, until one side of the water baffle comes out of the pin hole.

### 15. Deactivation/overwintering of ice machine

If the ice machine is out of service for a long time or is exposed to an environment of 0°C or

#### Note

In an environment below 0°C, if water is left in the machine, it may cause serious damage to the machine parts. Failures caused by this reason are not covered by the warranty.

below, special protective measures are required. Please follow the steps below:

- Disconnect the power supply of the ice maker.
- Disconnect the water source of the ice maker.
- Drain the water in the sink.
- Disconnect the water inlet pipe from the back of the ice machine to empty the water in the water inlet pipe.
- Ensure that no water remains in the water inlet pipe, drain pipe, and water distribution pipe.

#### ! Warning

Danger-There is a risk of fire or explosion. The refrigerant is a flammable refrigerant. Do not use mechanical equipment to disassemble the ice maker, and do not damage the refrigeration pipelines.

### 16.Maintenance

#### ! Warning

Danger-There is a risk of fire or explosion. The refrigerant is a flammable refrigerant. Only trained service personnel can carry out repair work. Do not damage the refrigeration piping.

#### ! Warning

Danger-There is a risk of fire or explosion. The refrigerant is a flammable refrigerant. Please read the service manual before using this product. All safety measures must be taken.

#### ! Warning

Warning-there is a risk of fire or explosion. Properly dispose of in accordance with federal or local regulations. The refrigerant is a flammable refrigerant.

#### ! Warning

Warning-There is a risk of fire or explosion if the pipeline is damaged. Follow the instructions carefully. The refrigerant is a flammable refrigerant.

## Maintenance

Before reporting for repairs, please consider the following aspects in order to quickly determine and improve the efficiency of machine recovery.

- a) . Whether the water supply is normal, including whether the faucet is open, whether the inlet valve is blocked, and whether the water pressure is too low or too high.
- b) . Whether the power supply is normal, including whether the voltage is too low, whether the switch is turned on, whether the fuse is burned out, and whether the plug is pulled out.
- c) . Whether the ambient temperature is too high or too low (the working environment temperature range of the ice maker is 10°C ~ 38°C), and whether the water temperature is too high or too low (the water temperature range is 5°C ~ 32°C).
- d). Whether the storage refrigerator is full and whether it can work after cleaning. Write down the machine number and computer board number, and call the toll-free number on the service label.

### 17. Circuit diagram

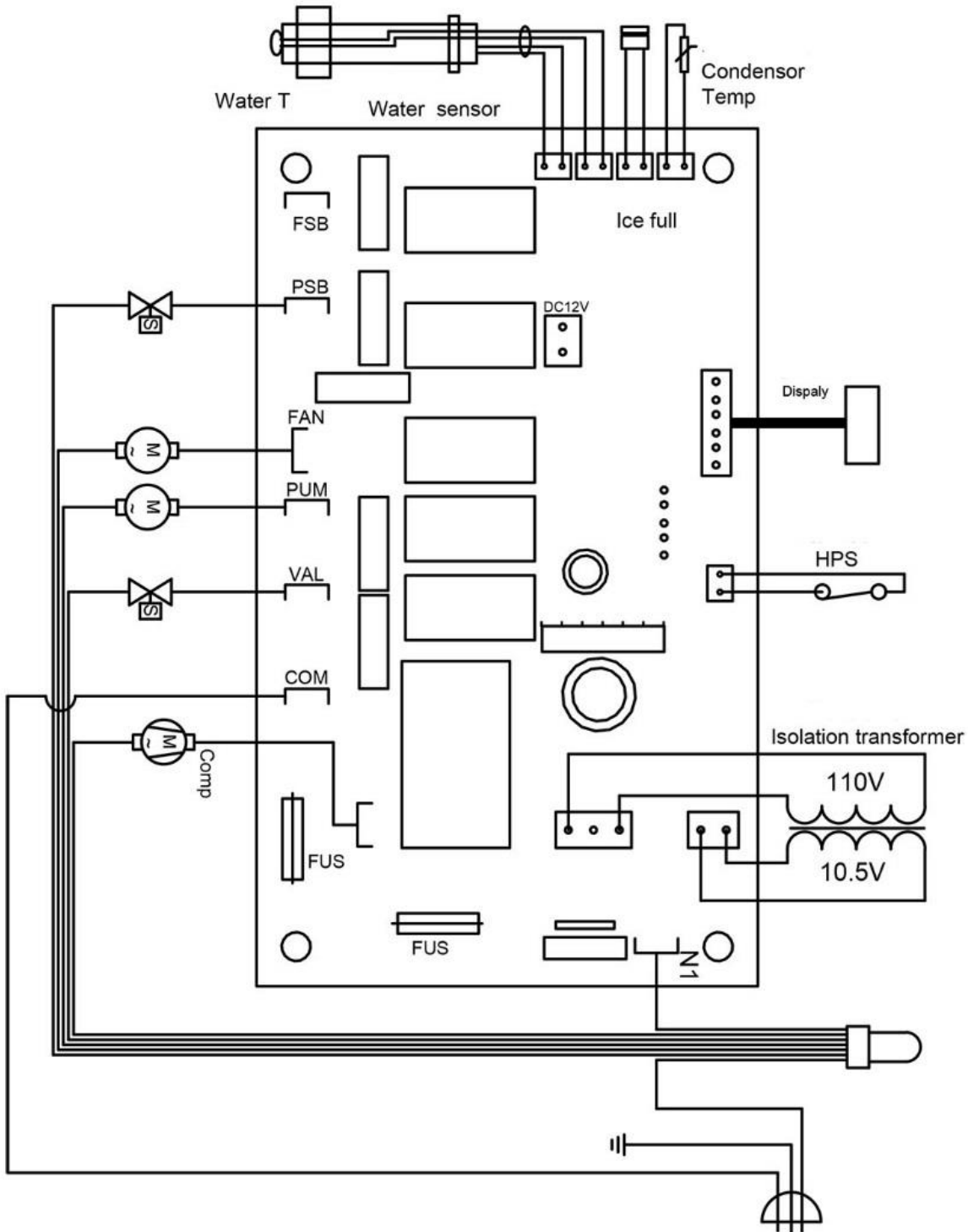

### 18. Explosive view

#### Structural Explosive view

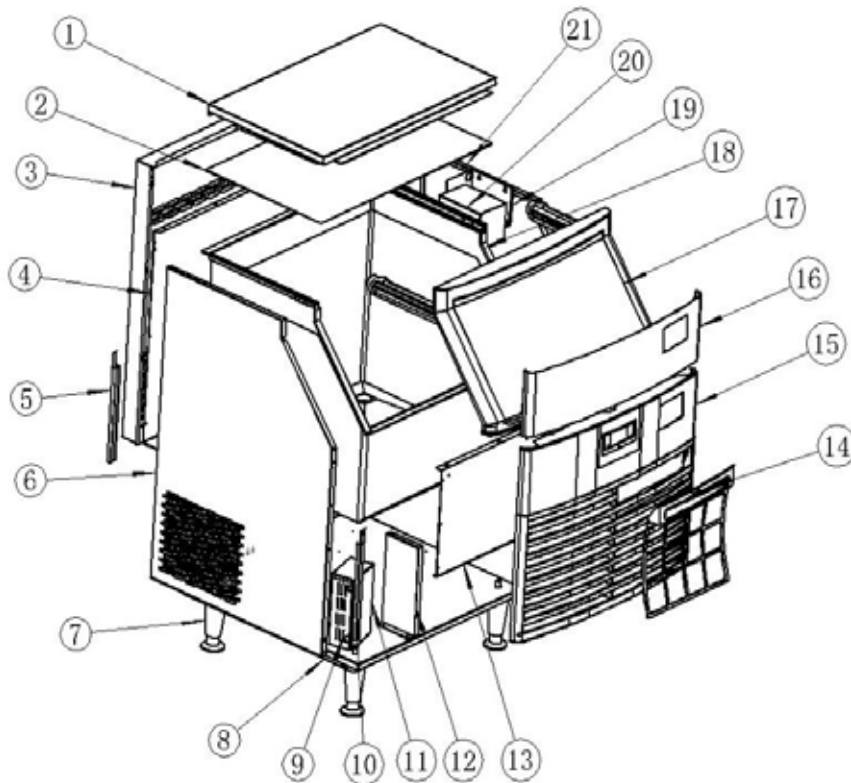

Serial	Figure	E-UCF160 E-UCF160	E-UCF210 E-UCH210	E-UCF280 E-UCH280	E-UCF310 E-UCH310	Serial	Figure	E-UCF160 E-UCF160	E-UCF210 E-UCH210	E-UCF280 E-UCH280	E-UCF310 E-UCH310
1	Top cover plate	1	1	1	1	12	Wind screen	1	1	1	1
2	PP sheets	1	1	1	1	13	The guard B	1	1	1	1
3	Postnotum	1	1	1	1	14	Filter net	1	1	1	1
4	The guard A	1	1	1	1	15	Ventlight	1	1	1	1
5	After poppet	2	2	2	2	16	Decorative	1	1	1	1
6	Left side plate	1	1	1	1	17	Door frame	1	1	1	1
7	Adjustable foot	4	4	4	4	18	Ice pail	1	1	1	1
8	Baseplate	1	1	1	1	19	Water pump	1	1	1	1
9	Electrical box	1	1	1	1	20	Water pump	1	1	1	1
10	Front bracket	2	2	2	2	21	Right side plate	1	1	1	1
11	Box cover	1	1	1	1	22		1	1	1	1

### Explosion diagram of refrigeration system

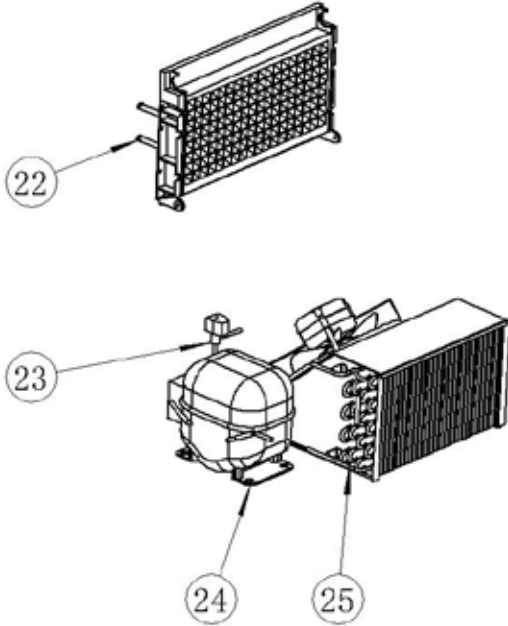

### Water system explosion diagram

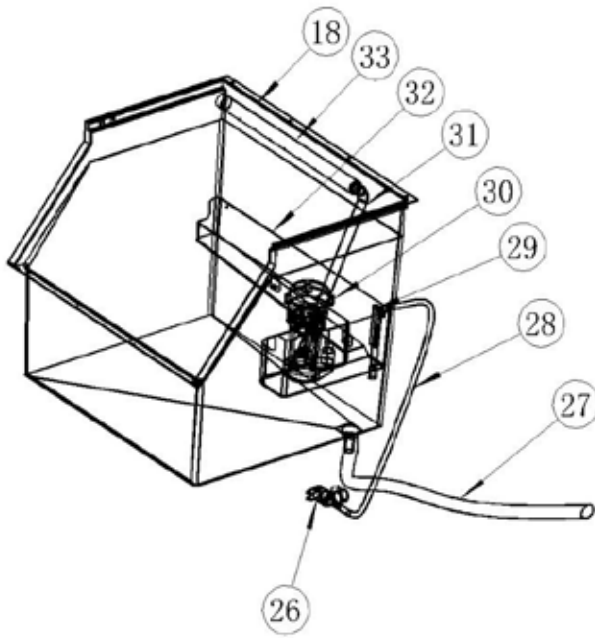

Serial	Figure	E-UCF160 E-UCF160	E-UCF210 E-UCH210	E-UCF280 E-UCH280	E-UCF310 E-UCH310
18	Ice pail	1	1	1	1
26	Intet valve	1	1	1	1
27	Drain-pipe	1	1	1	1
28	Intet pipe	1	1	1	1
29	Intake pipe ioint	1	1	1	1
30	Water pump	1	1	1	1
31	Water supply pipe	1	1	1	1
32	Water tank	1	1	1	1
33	Water pipe	1	1	1	1



### Explosion diagram of electrical control system

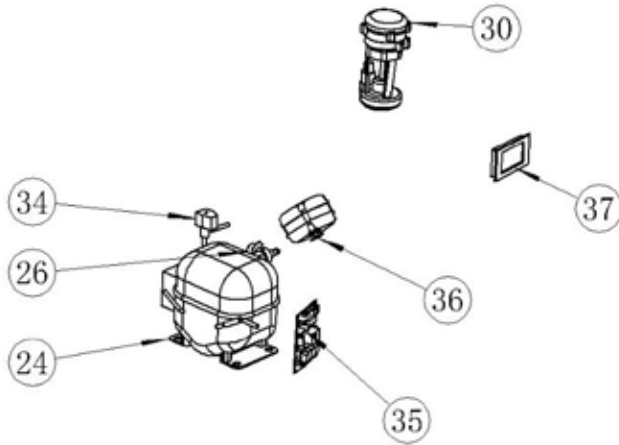

Serial	Figure	E-UCF160	E-UCF210	E-UCF280	E-UCF310
		E-UCF160	E-UCH210	E-UCH280	E-UCH310
24	Compressor	1	1	1	1
26	Intet valve	1	1	1	1
30	Water pump	1	1	1	1
34	Solenoid Valve Winding	1	1	1	1
35	Circuit board	1	1	1	1
36	Fan	1	1	1	1
37	Dispaly	1	1	1	1