

17" Countertop Refrigerated Showcase with Four Sided Glass and Stainless Steel Base 2.75cu.ft. / 78L- 110V, 180W

ITEM: 39551

MODEL: RS-CN-0078



Attractively display food merchandise and increase impulse sale.

Display your products brilliantly with the 17-inch Countertop Refrigerated Showcase with Four-Sided Glass and Stainless Steel Base. The glass display makes sure that your customers have all round view of your refrigerated products.

This unit has a large capacity that let's you store and display many products at once, and this especially helpful for busy stores.

It uses the environment friendly R290 refrigerant. The digital temperature controller lets you control the product temperature and also allows light control of the LED lamp that illuminates the interior to highlight your products.

FEATURES:

- Eye catching internal LED lighting
- Stainless steel exterior and interior
- Digital temperature controller and display
- Adjustable PVC coated shelves
- Maintenance free controller
- Single access

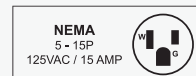

TECHNICAL DRAWING

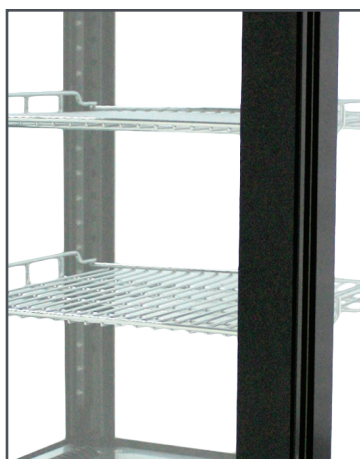
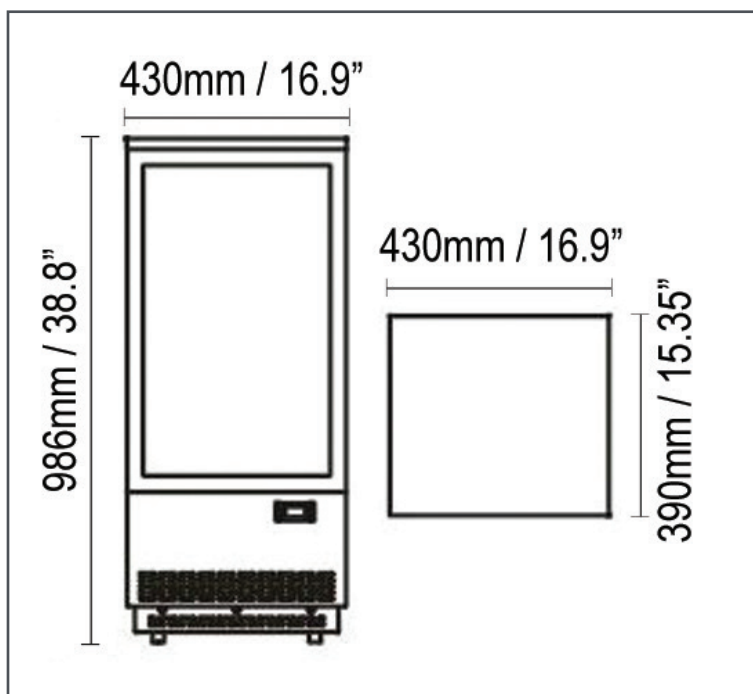

TECHNICAL SPECIFICATION

Item	39551
Model	RS-CN-0078
Capacity	2.75cu.ft. / 78L
Maximum Load	33lb. / 15kg.
Number of Doors	1 Swing Door
Number of Shelves	3
Shelf Size	12.5" x 12" / 317 x 305 mm
Shelf Material	Chrome
Interior Material	Plastic + Metal
Exterior Material	Metal
Number of Casters	n/a
Power	180W
Lamp Power	5.76W
Amps	1.6 A
Electrical	110V / 60Hz / 1Ph
Temperature Controller	Digital
Temperature Range	12 to 0°C / 54 to 32°F
Refrigerant	R290
Injection	40g
Type of Climate	4
Insulation Material	NA
Defrosting	Automatic
Cooling System	Forced Air
Interior Dimensions (WDH)	13.8" x 15.7" x 25.3" / 351 x 399 x 643 mm
Net Weight	74.5 lb. / 33.8 kg.
Net Dimensions (WDH)	15.35" x 17" x 39" / 390 x 432 x 991 mm
Gross Weight	80.25 lb. / 36.4 kg.
Gross Dimensions (WDH)	15.35" x 19" x 41" / 390 x 483 x 1041 mm