



Project _____
 AIA # _____ SIS # _____
 Item # _____ Quantity _____ C.S.I. Section 114000



HWS-4-ES

Energy Smart Hand-Wrap Station



HTsP/HTiP
 Hand-Wrap System with Color Touch Screen



Access Scale
 Hand-Wrap System with Color Touch Screen

SPECIFIER STATEMENT

The Hobart hand wrapping system is designed for the operator to manually weigh and wrap a package, then place the wrapped package on the heated sealing pad. A separate remote printer (HTsP, HTiP, HTxP, EPCP-5i, EPCP-6x, EPP-3) will compute the price and print the label for the operator to manually apply to the package. This unit is proven to significantly reduce energy costs by up to 80%. The Hobart HWS-4-ES is an on-demand hand wrap machine, where the seal plate only consumes energy when you need to seal a package. The photo eye sees the product and actuates the seal cycle.

MODEL

- HWS-4-ES** Energy smart hand-wrap station

STANDARD FEATURES

- + Film cradle mount for quick and easy film changeover
- + Fingertip film selection
- + Self-regulating square rod for increased transversal rigidity and consistent cutting
- + On-demand heated seal plate that significantly reduces power consumption by up to 80%
- + Thermistor controlled circuit that reduces power consumption as residual heat increases in seal plate
- + Dual outlet accessory plug in with GFCI for improved circuit integrity and protection
- + All stainless steel construction
- + 20" maximum roll width, 8" maximum roll diameter
- + Supplied with a replaceable non-stick cover to maintain a hygienic seal surface
- + Adjustable, oversized stainless steel foot pads for easy leveling on uneven floors
- + Rounded stainless steel front plate for easy wipe down
- + 2 stainless steel side shelves
- + Operates in all ambient temperatures
- + Convenient outlet provided for scale/printer power

ACCESSORIES (Available at extra cost)

- ACCESS-ESKIT – HWS post assembly plate for printer, USB cable and power cable for control panel (to be used with EPP and EPCP configurations)
- HT-ESKIT – HWS single printer post, bracket and scale support (to be used with a HTiP or HTsP)

HWS-4-ES ENERGY SMART HAND-WRAP STATION

Approved by _____ Date _____ Approved by _____ Date _____



HWS-4-ES

Energy Smart Hand-Wrap Station

SPECIFICATIONS

Construction: Heavy-duty stainless steel frame.
39" H x 25"W x 28.5"D. Shelf 14"W x 22"D.

Hot Plate: 15" W x 6"D.

Film Holders: Two roll film selector.
Capacity 8" diameter x 20" maximum.

Electrical: 115 Volts, 60 Hertz, 132 Watts.

Shipping Weight: Approximately 100-125 lbs. depending on options

NOTE: CONSOLE, PRINTER AND POST MUST BE ORDERED SEPARATELY.

DETAILS AND DIMENSIONS

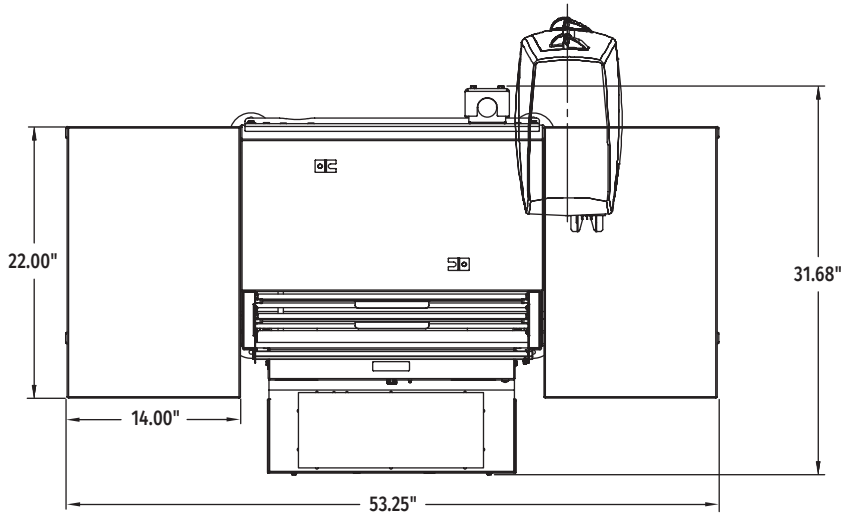

Access Hand-Wrap System

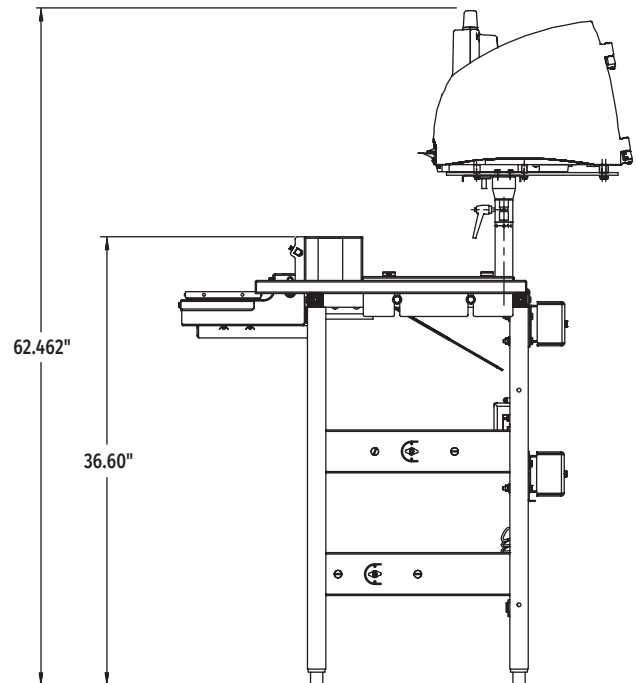
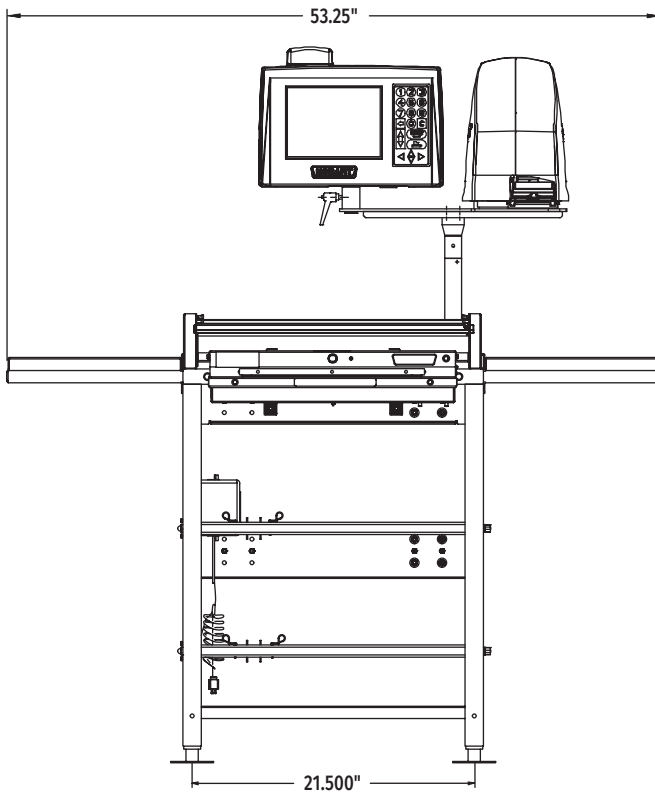



REMOTE SCALE OPTION SPECIFICATIONS

MODEL	CONSOLE	PRINTER	WEIGHER	CAPACITY
Access Hand-wrap System	EPCP-5i or EPCP-6x	EPP-3	EPSA-1	50 x 0.01 lb
Access Hand-wrap System	EPCP-5i or EPCP-6x	EPP-3	EPSA-2	30 x 0.01 lb
HT Hand-wrap System	HTsP, HTiP, or HTxP		SASCALE-2	12 x 0.005 lb, 30 x 0.01 lb

DETAILS AND DIMENSIONS

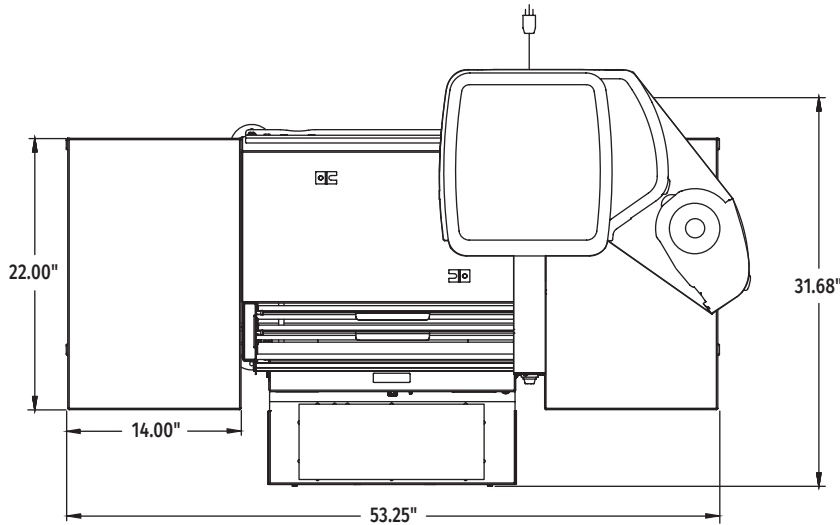

HTsP/HTiP Hand-Wrap System

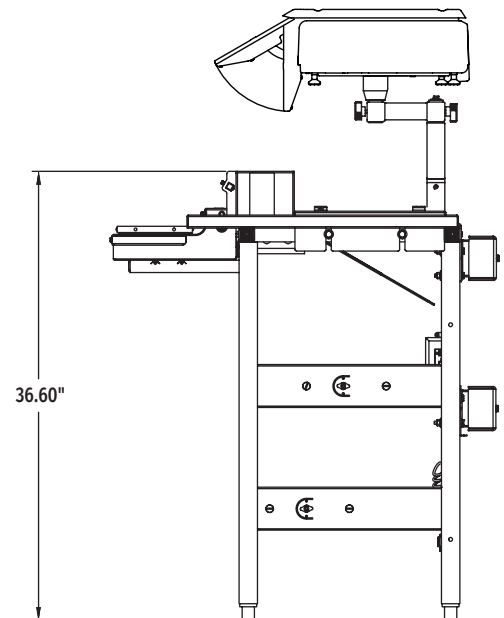
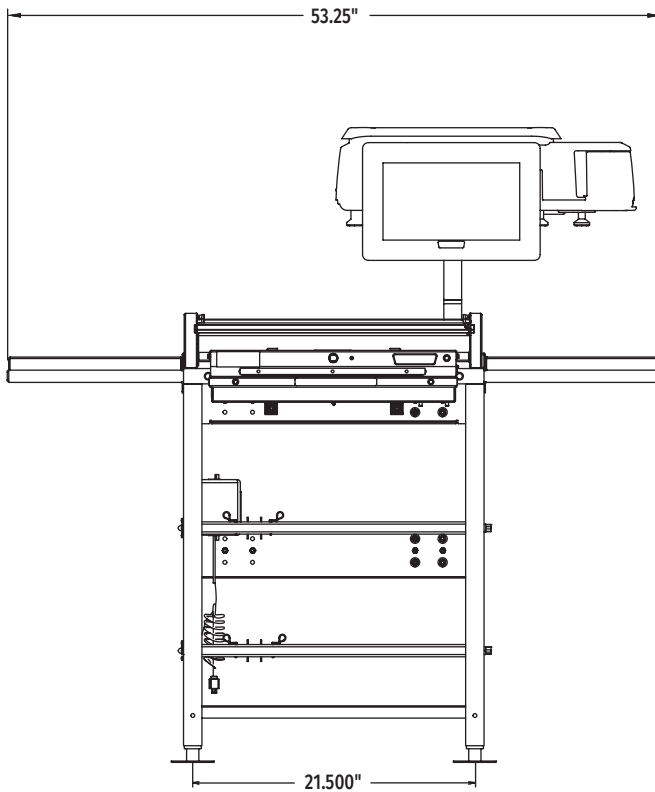

As continued product improvement is a policy of Hobart, specifications are subject to change without notice.