

Constructive Features

- cooking vessel in stainless steel AISI 304 (bottom thickness 12 mm and wall thickness 3 mm). Vessel with electric tilting on front part
- insulated lid with double cover in stainless steel AISI 304, with ergonomic handle, balanced by means of gas springs
- self-supporting frame in stainless steel AISI 304 (thickness 30-40/10)
- outer cover in stainless steel AISI 304, fine satin finish (thickness 12-15/10)
- adjustable feet in stainless steel AISI 304 to ensure levelling, with removable cover for cleaning operations
- fast accessibility to the main functional parts (electronic card, fuses, thermostats...) only removing the frontal panels
- protection level IPX4

Functional Features General

- heating by means of high efficiency stainless steel tube burners
- automatic ignition and flame control system without pilot burner
- heating controlled by electronic board
- temperature control by system with two probes (product/bottom)
- automatic mixing device with three arms and PTFE scrapers, completely removable to make cleaning easier, with regulation directly from the control panel according to the product to be processed
- electronic control by means of multifunctional keyboard with Touch Screen 7" and easy and clear messages
- USB connection to download HACCP data, update the software and load cooking programs
- ability to interrogate the machine using communication protocol MODBUS over RS485 serial interface

Panel Board Functions

- ON/OFF switch
- resistive 7" touch screen
- keys to turn on/off the mixer and move basin
- selection of 3 different cooking modes, with working temperature setting
- cooking type and time setting
- cooking in "Manual" mode
- cooking in "Program" mode
- creating and editing multiphase cooking programs, setting for each phase: cooking type; cooking parameters (temperature and time); mixer settings and possibility to insert text messages
- speed setting/adjustment (clockwise and counterclockwise) rotation times and mixer pause times
- possibility to activate mixer at minimum speed during tank tilting to facilitate product pouring
- tank water load setting (hot up to 140° F/cold) with automatic liter measurements
- control for tilting and return of cooking tank from Touch Screen or keyboard
- delayed cooking setting with date, time, and programming cycle
- language settings touch Screen
- input of different units of measurement (° C/° F; Liters/gallons; etc)

Display/Signal

- display type of cooking, temperature probes used and set temperature
- heating operating visual alarm
- time to end of cycle display
- display tank out of position for cooking
- audible/visible warning of mixer program start
- signaling tap position, managing water in the tank
- signal of lid and cock position during vat tilting
- signalling and blocking heat in case there is no gas
- gas control unit "RESET" message
- thermostat intervention safety signaling
- self-diagnostics

Safety System

- emergency button
- blocking of heating for excess of temperature with manual resettable safety thermostat
- heating interruption during vat tilting



Optionals

- CADE0010 - CLEANING SHOWER FOR CBT/PR
- D150 - KIT WHEELS PR/CBT/DBR
- DAPF0010 - SET FEET FOR DBR/CBT/PR
- PAF2050 - TRI-CLOVER SANITARY FITTINGS 2"
- PAF2060 - TRI-CLOVER SANITARY FITTINGS 3"

Accessories

- CAGM132 - EXTRA GRID FOR MIXER CBT.130
- CAPV2040 - EXTRA SCRAPER VERTICAL MIXER CBT130
- PAF0701 - STRAINER FOR CBT.090-130

Certificates



Planner

.....

.....

.....

.....

.....

.....

.....

.....

.....

.....

* REG. 0 ; + 1 $\frac{5}{8}$ "

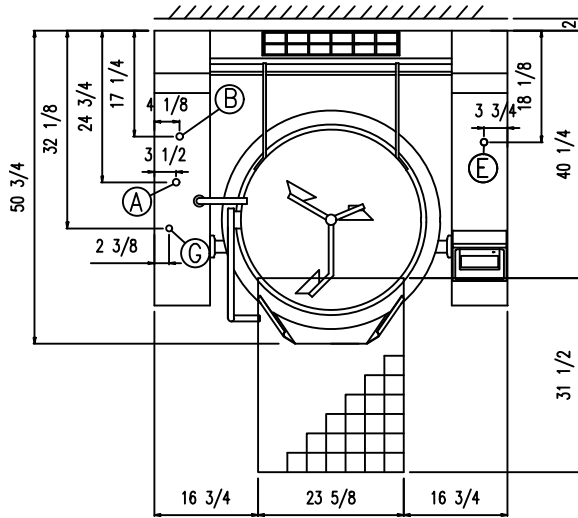
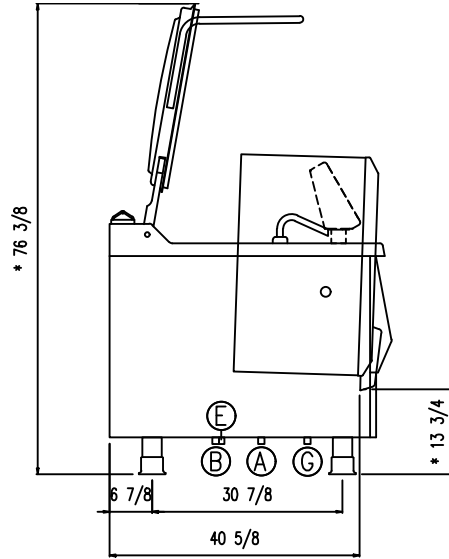
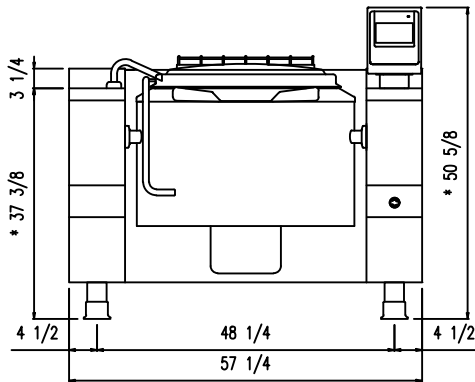

Dimensions weights and capacities

Width	57 1/4 inch	Vessel diameter	50 3/4 inch	Cooking vessel surface	589 inch ²
Depth	50 3/4 inch	Vessel height	15 3/4 inch	Weight	1025 lb
Height	50 5/8 inch	Capacity	34 gal		

Mixer

Mixer torque	191 Nm	Mixer power	0.37 kW	Mixing speed	6-18 Rpm
--------------	--------	-------------	---------	--------------	----------

Water connection

Water pressure	25±50 KPa	Cold water inlet (B)	3/4"	Hot water inlet (A)	3/4"
----------------	-----------	----------------------	------	---------------------	------

Gas connection

Gas connection (G)	3/4"	Gas power	95.500 BTU/h		
--------------------	------	-----------	--------------	--	--

Electrical connection

STD Voltage (E)	2 PHASE 220-240V ~ 60Hz	Electric power	0.60 kW	Current	--- A
OPT Voltage (E)	2 PHASE 208V ~ 60Hz	Electric power	0.50 kW	Current	--- A