



# SPEC SHEET

## KoolMore 29 in. Commercial Stainless Steel Solid Half Door Reach-In Freezer 23 cu. ft.

SKU: RIF-1D-SSHD

### FEATURES

- Ideal for restaurants, cafes, hotels, and commercial kitchens. A bottom-mounted compressor and raised bottom shelf make for convenient loading, unloading, and maintenance. Features recessed handles for easy access, a self-closing feature that ensures food remains frozen and fresh and three deep adjustable shelves coated in epoxy for maximum corrosion resistance.
- This tall freezer can hold up to 23 cu. ft. of space, counts with external digital controls, and display to easily monitor and control temperature. The 4 casters make it highly portable for kitchen convenience.
- Highly certified: ETL Listed for Safety and Sanitation, making it NSF ANSI 7 Standard for Commercial refrigerators.



### CLOSE UP IMAGES



# TECHNICAL SPECS

## Dimensions

Depth	23.5
Width	24.8
Height	63.3
Interior Depth	18.7
Interior Width	21.1
Interior Height	44.5
Shelf Width	20.2
Shelf Depth	17.7
Depth Including Handles	23.5
Depth Excluding Handles	23.5
Depth Less Door	20.7
Depth With Door Open 90 Degrees	46.4
Power Cord Length	98.5

## Capacity

Gross Cubic Feet	11
Net Capacity Cu. Ft.	10.1
Individual Shelf Capacity	88l bs.

## Features & Material

Door Style	Swing
Number Of Doors	1
Number Of Shelves	3
Defrost Type	Automatic
Refrigerant Type	R-290
Temperature Control Type	External Digital
Ambient Temperature Range	100 F
Temperature Range	- 7 F~0 F
Casters	4
Light Type	Fluorescent Bulb
Shelf Material Type	Epoxy Coated
Interior Material	Stainless Steel 201
Exterior Material	Stainless Steel 304

## Electric Data & Certifications

Amps	4.7
Phase	1
Plug Type	NEMA 5-15P
Voltage	115
Certifications	ETL Listed for Safety and Sanitation

# Plan View

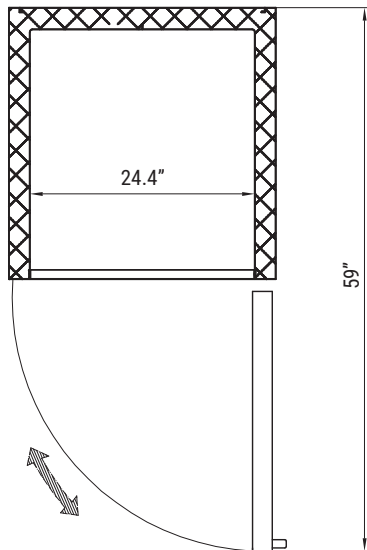
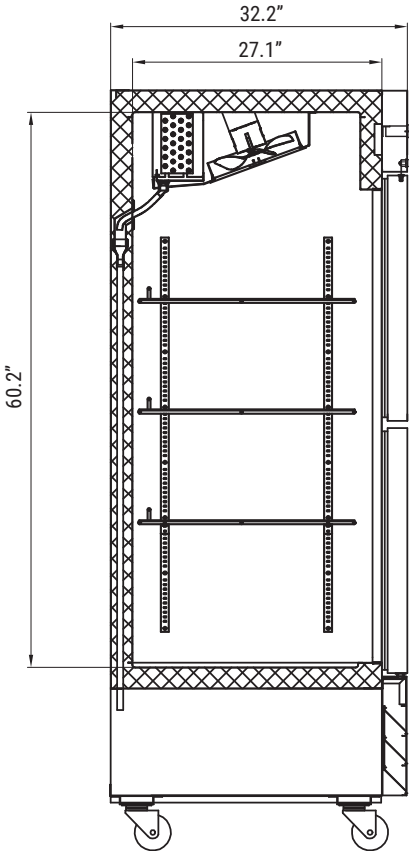
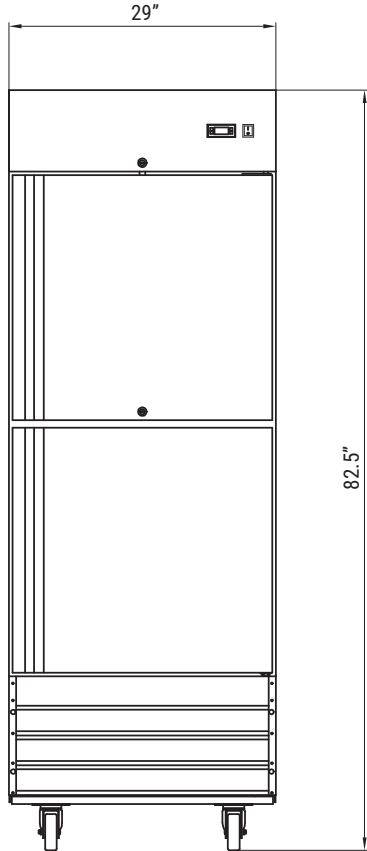

**CERTIFICATIONS**

ETL C-Listed US Intertek

ETL Certification Limited Intertek



706 Eastern Parkway STE 1G, Brooklyn NY 11213  
718-576-6342  
info@koolmore.com