



Profit from the Eagle Advantage®

# Specification Sheet

## Short Form Specifications

Eagle Divider Wall Extension Shields. Unit clamps onto standard divider wall to extend protection. Multiple size options available to accommodate a range of divider wall lengths. Custom sizes also available.



Item No.:	_____
Project No.:	_____
S.I.S. No.:	_____

## Divider Wall Extension Shields

### MODELS:

- BGDW-2424
- BGDW-2436
- BGDW-2448
- BGDW-2460
- BGDW-2472

### Design and Construction Features

- Clamps onto standard cubicle/divider wall to extend protection.
- Clamps provide customizable range to accommodate range of thicknesses.
- 7/32"-thick durable plexiglass.

### Options / Accessories

- Upgrade to polycarbonate
- Company logo added
- Custom edge banding
- Custom configurations

### EAGLE GROUP

100 Industrial Boulevard  
Clayton, DE 19938-8903 USA

Phone: 302-653-3000 • 800-441-8440

Fax: 302-653-2065

[www.eaglegrp.com](http://www.eaglegrp.com) • [www.eaglemhc.com](http://www.eaglemhc.com)

For custom configuration or fabrication needs, contact our **SpecFAB®** Division.

Phone: 302-653-3000 • Fax: 302-653-2065 • e-mail: [quotes@eaglegrp.com](mailto:quotes@eaglegrp.com)

### Certifications / Approvals



SEFA 8 Metal Casework

EG06.07 Rev. 10/20

**Spec sheets available for viewing, printing or downloading from our online literature library at [www.eaglegrp.com](http://www.eaglegrp.com)**

*Eagle Foodservice Equipment, Eagle MHC, and SpecFAB® are divisions of Eagle Group. ©2020 by the Eagle Group*



Item No.: \_\_\_\_\_  
 Project No.: \_\_\_\_\_  
 S.I.S. No.: \_\_\_\_\_

# Divider Wall Extension Shields

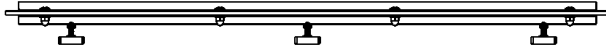

TOPVIEW

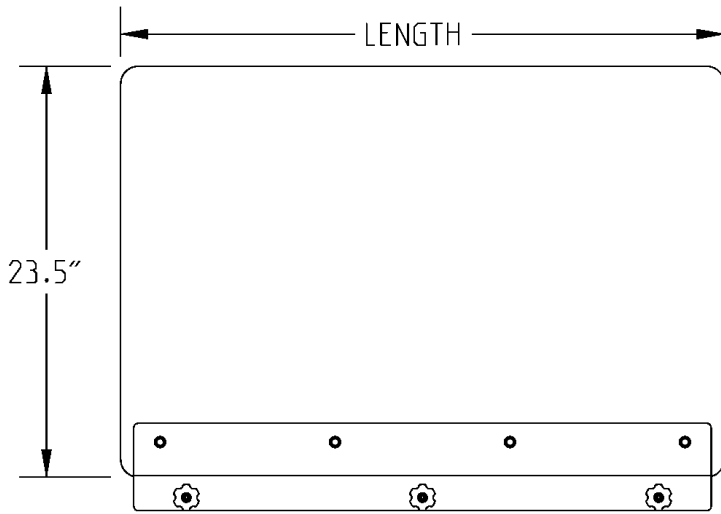

FRONT VIEW

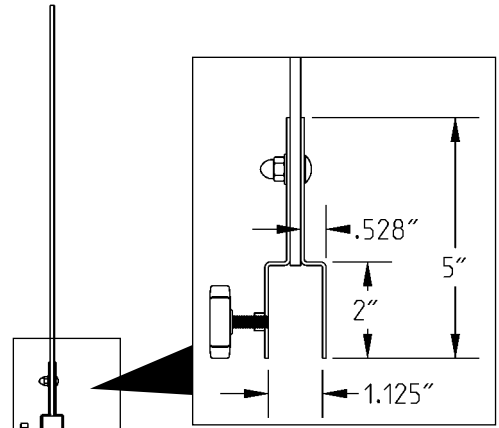

SIDE VIEW OF CLAMPS

SIDE VIEW

height		length		quantity per pack	model #
in	mm	in	mm		
24"	610	24"	610	1	<b>BGDW-2424</b>
24"	610	36"	914	1	<b>BGDW-2436</b>
24"	610	48"	1219	1	<b>BGDW-2448</b>
24"	610	60"	1524	1	<b>BGDW-2460</b>
24"	610	72"	1829	1	<b>BGDW-2472</b>

**EAGLE GROUP**  
 100 Industrial Boulevard, Clayton, DE 19938-8903 USA  
 Phone: 302-653-3000 or 800-441-8440 • Fax: 302-653-2065  
 www.eaglegrp.com • www.eaglehmc.com

Printed in U.S.A.  
 ©2020 by Eagle Group  
 Rev. 10/20

Spec sheets available for viewing, printing or downloading from our online literature library at [www.eaglegrp.com](http://www.eaglegrp.com)

Although every attempt has been made to ensure the accuracy of the information provided, we cannot be held responsible for typographical or printing errors. Information and specifications are subject to change without notice. Please confirm at time of order.