



Profit from the Eagle Advantage®

# Specification Sheet

## Short Form Specifications

Eagle Director's Choice® Hot Food Service Counter, model \_\_\_\_\_ . Top to be 16/304 stainless steel turned down on all sides. Fully welded 1½" square stainless steel tubular frame with type 304 aprons on all sides. Sealed wells accept 12" x 20" food pans, and feature individual thermostatic controls. Single or three phase, wired to a 10' cord and plug. Fully mobile with 5" poly tread casters, half with brake.



"U" shaped unit



"L" shaped unit

## Options / Accessories

- End panels (in lieu of aprons)
- Front panels (in lieu of aprons)
- Stainless steel tray slide\*
- Work shelf\*\*
- Plate shelves
- Convenience outlets
- Bullet feet (in lieu of casters)
- Removable undershelves

\* Available in solid ribbed, square tubular or round tubular. For front, rear, or ends. See spec sheet #EG33.07

\*\* Available in hardwood, stainless steel, poly, or Richlite®. For front, rear, or ends. See spec sheet #EG33.07

**EAGLE GROUP**  
 100 Industrial Boulevard, Clayton, DE 19938-8903 USA  
 Phone: 302-653-3000 • Fax: 302-653-2065  
 www.eaglegrp.com

**Foodservice Division: Phone 800-441-8440**  
**MHC/Retail Display Divisions: Phone 800-637-5100**

For custom configuration or fabrication needs, contact our **SpecFAB® Division**.  
 Phone: 302-653-3000 • Fax: 302-653-3091 • e-mail: specfab@eaglegrp.com

Item No.: \_\_\_\_\_  
 Project No.: \_\_\_\_\_  
 S.I.S. No.: \_\_\_\_\_

## Director's Choice® Hot Food Service Counters

### MODELS:

- DCS3-TMU-A
- DCS3-TMU-B
- DCS3-TMU-B-3
- DCS3-TMU-C
- DCS3-TMU-C-3
- DCS4-TMU-B
- DCS4-TMU-B-3
- DCS4-TMU-C
- DCS4-TMU-C-3
- DCS5-TMU-B
- DCS5-TMU-B-3
- DCS5-TMU-C
- DCS5-TMU-C-3
- DCS6-TMU-B
- DCS6-TMU-B-3
- DCS6-TMU-C
- DCS6-TMU-C-3
- DCS4-TMLL-B
- DCS4-TMLL-B-3
- DCS4-TMLL-C
- DCS4-TMLL-C-3
- DCS4-TMLR-B
- DCS4-TMLR-B-3
- DCS4-TMLR-C
- DCS4-TMLR-C-3

### Design and Construction Features—All Models

- Top is constructed of 16 gauge type 304 stainless steel, welded and polished.
- Welded 1½" (38mm) type 304 stainless steel square tubular base construction.
- Fully-insulated heat wells are sealed, accept 12" x 20" (305 x 508mm) food pans, and feature individual thermostat controls.
- Single or three phase, wired to a 10' (3048mm) cord and plug.
- Fully mobile - standard 5" (127mm) poly tread casters.
- ¾" (19mm) drain.

### "U"-Shaped Models

- Includes eight 5" (127mm)-diameter casters, four with brake.

### "L"-Shaped Models

- Includes five 5" (127mm)-diameter casters, three with brake.

### Certifications / Approvals



### AUTOQUOTES



EG33.20 Rev. 08/12

**Spec sheets available for viewing, printing or downloading from our online literature library at [www.eaglegrp.com](http://www.eaglegrp.com)**

Eagle Foodservice Equipment, Eagle MHC, SpecFAB®, and Retail Display are divisions of Eagle Group. ©2012 by the Eagle Group



Profit from the Eagle Advantage®

Item No.: \_\_\_\_\_  
 Project No.: \_\_\_\_\_  
 S.I.S. No.: \_\_\_\_\_

## Director's Choice® Hot Food Service Counters

Model number with suffix **-A** = 120V unit with 1200W per well.  
 Model number with suffix **-B** = 208V/240V unit with 900W/1200W per well.  
 Model number with suffix **-C** = 208V/240V unit with 1200W/1600W per well.

### "U" Shaped Units

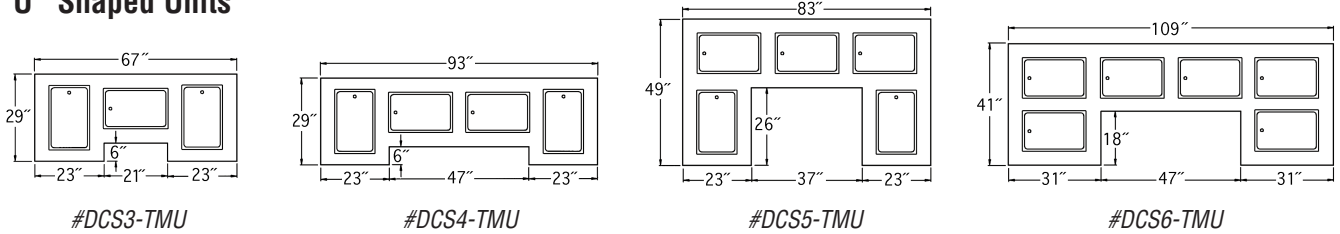

# of wells	volts	watts	SINGLE-PHASE			THREE-PHASE		
			amps	NEMA plug	model #	amps	NEMA plug	model #
3	120V	3600W	30.0A	5-50P	<b>DCS3-TMU-A</b>	-	-	n/a
3	208/240V	2700/3600W	13.0/15.0A	5-20P	<b>DCS3-TMU-B</b>	7.5/8.7A	15-20P	<b>DCS3-TMU-B-3</b>
3	208/240V	3600/4800W	17.3/20.0A	5-30P	<b>DCS3-TMU-C</b>	10.0/11.6A	15-20P	<b>DCS3-TMU-C-3</b>
4	208/240V	3600/4800W	17.3/20.0A	5-30P	<b>DCS4-TMU-B</b>	11.5/13.2A	15-20P	<b>DCS4-TMU-B-3</b>
4	208/240V	4800/6400W	23.1/26.7A	5-30P/5-50P	<b>DCS4-TMU-C</b>	15.3/17.7A	15-20P/15-30P	<b>DCS4-TMU-C-3</b>
5	208/240V	4500/6000W	21.6/25.0A	5-30P/5-50P	<b>DCS5-TMU-B</b>	15.0/17.3A	15-20P/15-30P	<b>DCS5-TMU-B-3</b>
5	208/240V	6000/8000W	28.8/33.3A	5-50P	<b>DCS5-TMU-C</b>	20.0/23.1A	15-30P/15-30P	<b>DCS5-TMU-C-3</b>
6	208/240V	5400/7200W	26.0/30.0A	5-50P	<b>DCS6-TMU-B</b>	15.0/17.3A	15-20P/15-30P	<b>DCS6-TMU-B-3</b>
6	208/240V	7200/9600W	34.6/40.0A	5-50P	<b>DCS6-TMU-C</b>	20.0/23.1A	15-30P/15-30P	<b>DCS6-TMU-C-3</b>

### "L" Shaped Units

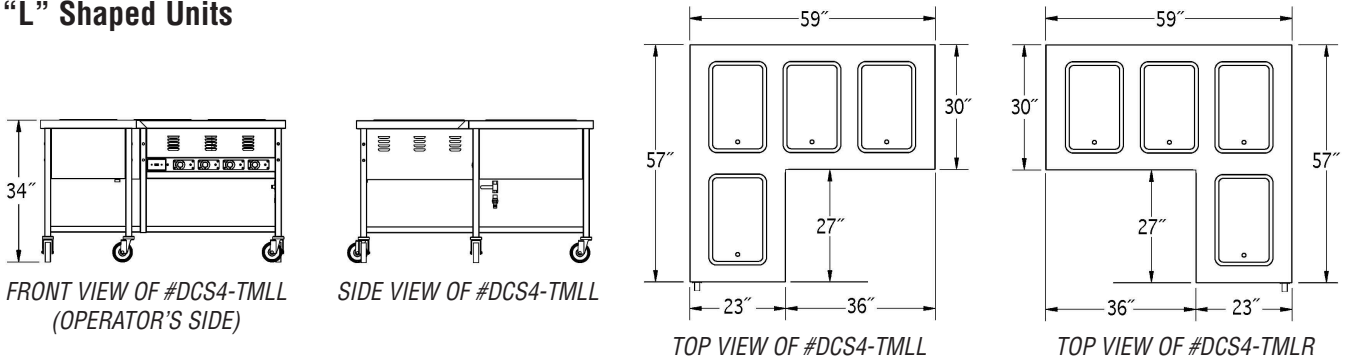

# of wells	volts	watts	SINGLE-PHASE			THREE-PHASE		
			amps	NEMA plug	model #	amps	NEMA plug	model #
4	208/240V	3600/4800W	17.3/20.0A	5-30P	<b>DCS4-TMLL-B</b>	11.5/13.2A	15-20P	<b>DCS4-TMLL-B-3</b>
4	208/240V	4800/6400W	23.1/26.7A	5-30P/5-50P	<b>DCS4-TMLL-C</b>	15.3/17.7A	15-20P/15-30P	<b>DCS4-TMLL-C-3</b>
4	208/240V	3600/4800W	17.3/20.0A	5-30P	<b>DCS4-TMLR-B</b>	11.5/13.2A	15-20P	<b>DCS4-TMLR-B-3</b>
4	208/240V	4800/6400W	23.1/26.7A	5-30P/5-50P	<b>DCS4-TMLR-C</b>	15.3/17.7A	15-20P/15-30P	<b>DCS4-TMLR-C-3</b>

"TMLL" indicates fourth well at left, standing at operator's side of unit.  
 "TMLR" indicates fourth well at right, standing at operator's side of unit.

**EAGLE GROUP**  
 100 Industrial Boulevard, Clayton, DE 19938-8903 USA  
 Phone: 302-653-3000 • Fax: 302-653-2065  
 www.eaglegrp.com

Foodservice Division: Phone 800-441-8440  
 MHC/Retail Display Divisions: Phone 800-637-5100

Printed in U.S.A.  
 ©2012 by Eagle Group  
 Rev. 08/12

Spec sheets available for viewing, printing or downloading from our online literature library at [www.eaglegrp.com](http://www.eaglegrp.com)

Although every attempt has been made to ensure the accuracy of the information provided, we cannot be held responsible for typographical or printing errors. Information and specifications are subject to change without notice. Please confirm at time of order.