

SLIMLINE DROP-IN SEALED WELL ELECTRIC UNIT



DISLSW-2-120 Shown

Item #:	_____	Qty #:	_____
Model #:	_____		
Project #:	_____		

FEATURES:

- Fiberglass insulation between each compartment
- 12" x 20" die stamped openings
- Full stainless steel construction inside and out.
- Remote control panel
- Units are supplied with drains for wet or dry application
- Includes 1" I.P.S. Drain(s) with Gate Valve

MATERIAL:

- TOP:** 18 gauge #304 stainless steel with die stamped pan openings and self rimmed. (12" x 20" opening)
- BODY:** 20 gauge galvanized



ELECTRICAL:

- 120V units yield 1100 Watts
- 208V/240V dual voltage units yield 825 Watts at 208V and 1100 Watts at 240V
- Infinite control knobs
- Indicator lights
- Unit to be hard wired in the field. Optional cord sets available, please consult the factory for more information**

Model #	O.A. Length	O.A. Width	# of Wells	Cut-Out Size	Volts	Amps	Watts	Approx. Wt.	Cu. Ft.
DISLSW-2-120	47-9/16"	16-7/16"	2	15-1/8" x 45-7/8"	120	18.33	2200	125 lbs.	12.8
DISLSW-3-120	70-3/8"	16-7/16"	3	15-1/8" x 68-3/4"	120	27.51	3300	150 lbs.	18.6
DISLSW-2-240	47-9/16"	16-7/16"	2	15-1/8" x 45-7/8"	208/240	3.94/9.16	1600/2200	125 lbs.	12.8
DISLSW-3-240	70-3/8"	16-7/16"	3	15-1/8" x 68-3/4"	208/240	11.90/13.34	2475/3300	150 lbs.	18.6
DISLSW-4-240	93-3/16"	16-7/16"	4	15-1/8" x 91-1/2"	208/240	15.88/18.32	3300/4400	174 lbs.	24.5

NOTE: Units are not designed to cook or heat frozen or refrigerated foods. Food placed in tables should already be hot, and the table will maintain the proper temperatures

Optional Accessories:

Visit our website for additional Food Table Accessories



Manifold Drains (Per Well)
Add The Suffix **-M** To The Model Number.

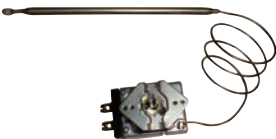

Thermostatic Controls
Add The Suffix **-T** To The Model Number.



SU-45A



Adapter Bars
SU-45A 12" x 1" Adapter Bar.

3-Phase Upgrade
SU-72 Upgrade to 240 volt units to 3 Phase Wiring.

Cord with NEMA Plugs

SU-P-230	6' Cord & NEMA 5-20P plug for 2 or 3 well, 120v Units	 NEMA 5-20P
SU-P-232	6' Cord & NEMA 6-20P plug for 2 or 3 well, 240v Units	 NEMA 6-20P
SU-P-233	6' Cord & NEMA L6-30P plug, for 4 well, 240v Unit	 NEMA L6-30P

DIMENSIONS and SPECIFICATIONS

TOL ± .125"

ALL DIMENSIONS ARE TYPICAL

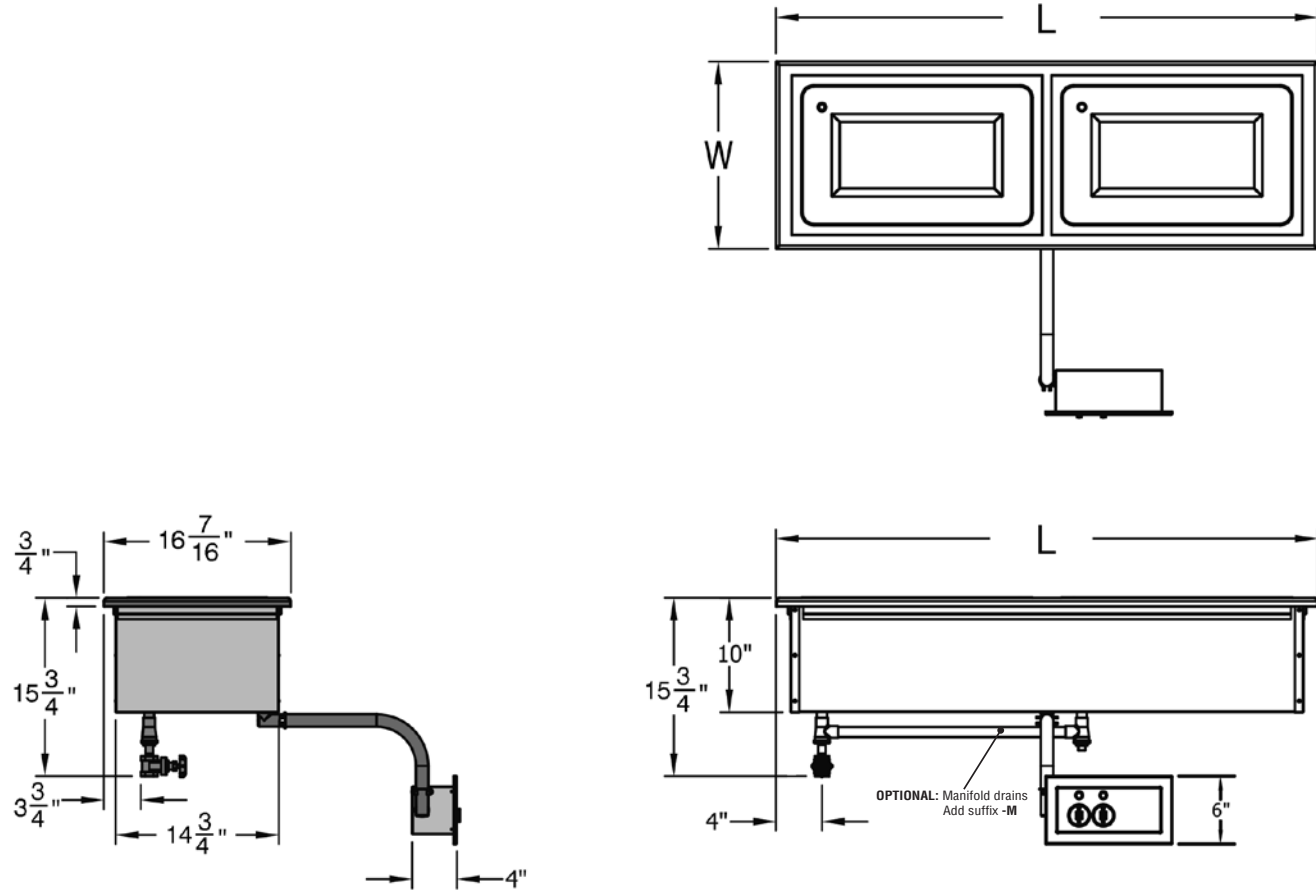

CONTROL PANEL SPECS

Model #	Cut-Out Size Length (A)	Cut-Out Size Height (B)	Front Panel Length (C)
DISLSW-2	9 -1/2"	4 -5/16"	11 -1/8"
DISLSW-3	15 -3/8"	4 -5/16"	17"
DISLSW-4	15 -3/8"	4 -5/16"	17"

Unit to be hard wired in the field. See Accessories for optional Cords.
Please consult the factory for more information.

