

# heatXpress

## Heated Display Cases

Model No.  
**DXP-DW18 &  
DXP-DW25**

Increase impulse sales with a DXP-DW18 & DXP-DW25 Heated Display Case. Ideal for convenience stores, concession stands, kiosks, and snack stations, display your food while keeping them at food safe temperatures.



### Features:

- Stainless steel construction
- 3 adjustable chrome plated shelves with a load capacity of 22lb each
- Back doors
- Water pan to add humidity
- Manual temperature control that ranges from 85-190°F
- External temperature display
- Internal top light
- Front top light box with decal
- Available in 18" (DXP-DW18) & 25" (DXP-DW25) widths



Model DXP-DW18



Water Pan



Manual Temperature Control



Temperature Display



Model BMCBF25

\*\*Due to continuous product improvement, specifications are subject to change without notice.



**doughXpress**

HIX Corporation Food Division

Product improvement may require us to change specifications without notice.  
Revised January 2020

**DOUGHXPRESS**

1201 E. 27th Terrace  
Pittsburg, KS 66762 USA

Toll Free: (800) 835-0606

Tel: (620) 231-8568

Fax: (620) 231-1598

[doughxpress@hixcorp.com](mailto:doughxpress@hixcorp.com) or visit [www.doughxpress.com](http://www.doughxpress.com)

# heatXpress

## Heated Display Cases

## Model No. DXP-DW18 & DXP-DW25

### Technical Specifications:

#### Model DXP-DW18

- Exterior Dimensions (WDH) 18" x 17.8" x 30.9"
- Shelf Size: 15.4" W x 13.3" D
- Net Weight 48.5 lb / 22 kg
- 120v / 7.2 Amps / 786W / 60Hz / 1Ph
- Nema 5-15P Plug

#### Model DXP-DW25

- Exterior Dimensions (WDH) 25.5" x 19" x 30.9"
- Shelf Size: 22.6" W x 13.3" D
- Net Weight 59.5 lb / 27 kg
- 120v / 9.5 Amps / 1050 W / 60Hz / 1Ph
- Nema 5-15P Plug

### Shipping Specifications:

#### Model DXP-DW18

- Packaged Dimensions (WDH) 21" x 21.1" x 32.8"
- Packaged Weight 50.5 lb / 22.9 kg

#### Model DXP-DW25

- Packaged Dimensions (WDH) 28.3" x 21.1" x 32.8"
- Packaged Weight 61.5 lb / 27.9 kg

Model DXP-DW18

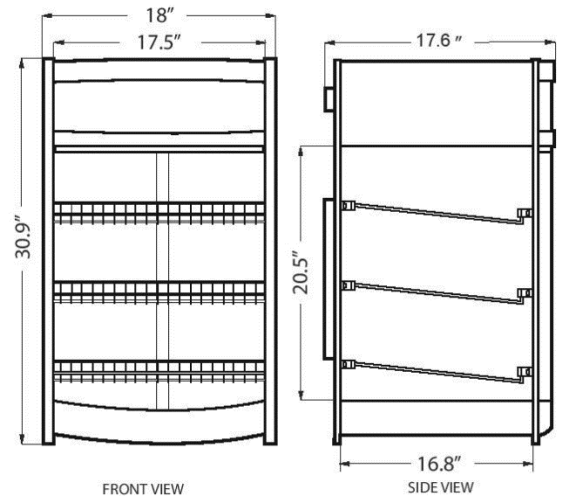

Model DXP-DW25

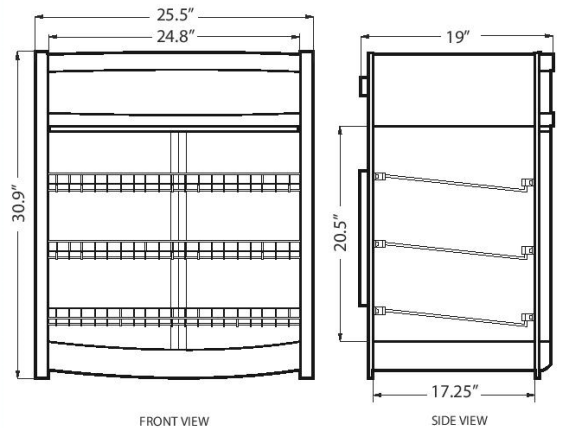

Model DXP-DW18



Model DXP-DW25

\*\*Due to continuous product improvement, specifications are subject to change without notice.



**doughXpress**

**HIX Corporation Food Division**

Product improvement may require us to change specifications without notice.  
Revised January 2020

**DOUGHXPRESS**

1201 E. 27th Terrace  
Pittsburg, KS 66762 USA

Toll Free: (800) 835-0606

Tel: (620) 231-8568

Fax: (620) 231-1598

[doughxpress@hixcorp.com](mailto:doughxpress@hixcorp.com) or visit [www.doughxpress.com](http://www.doughxpress.com)