

# TITAN STAINLESS CUSTOM FOODSERVICE FABRICATION

502 Usher Street · Pageland, SC · 704-243-8717 · [www.titan-stainless.com](http://www.titan-stainless.com)



## POLY TOP WORKTABLE WITH FLAT TOP AND UNDERSHELF

TITAN STAINLESS Poly Top worktables are made using 1/2" thick white polyboard and all-welded heavy gauge stainless steel construction. Assembly is not required. Polyboard rests on a stainless steel tubular frame below. 1-5/8" diameter tubing is welded to tubular frame; legs are furnished with adjustable stainless steel bullet feet. Full-length stainless steel undershelf is welded to the table legs. All welds are ground and polished to a smooth finish.



## MODEL NUMBER SELECTION / INFORMATION

(Example #: 5PTSU-30)

Poly top worktables are available in standard lengths from 3'-0" to 10'-0", in 1-foot increments. Standard widths (front-to-back) are available in 24" and 30". Units over 6'-0" long will be furnished with an additional set of legs.

- See **AutoQuotes™** for full list of model numbers and pricing, along with all additional accessories
- Custom sizes and configurations are available upon request

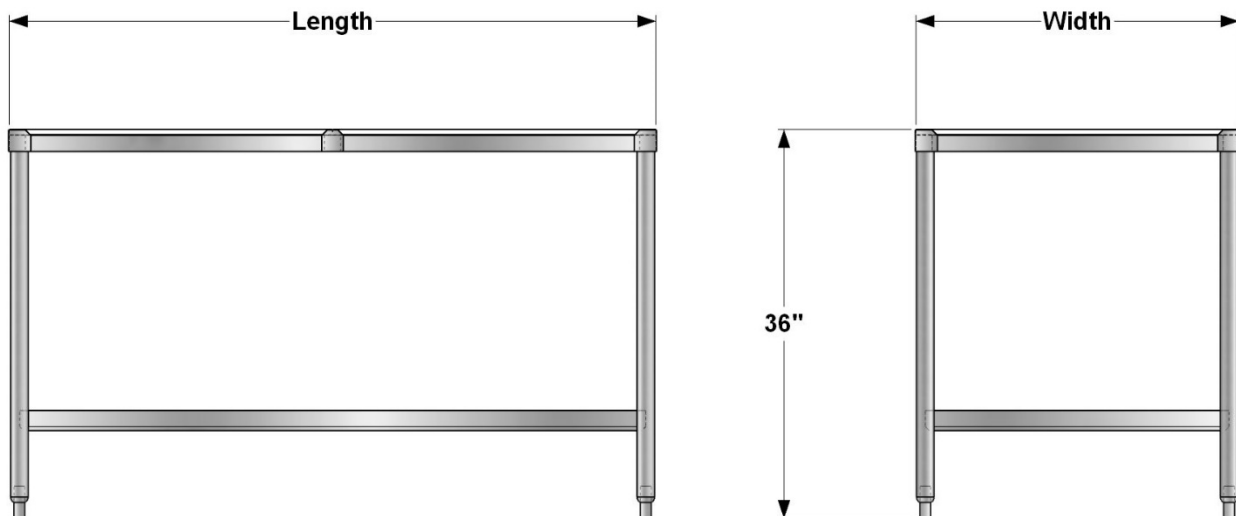

**TITAN STAINLESS**  
502 Usher Street · PO Box 8 · Pageland, SC 29728  
Contact: 704-243-8717 · [quotes@titan-stainless.com](mailto:quotes@titan-stainless.com) · [www.titan-stainless.com](http://www.titan-stainless.com)

