

ELTEK™ WATER BLOCK

DISTRIBUTED BY PENTAIR

OFFICE FLOOD PROTECTION AND PEACE OF MIND FOR ABOUT THE COST OF AN AIRPOT

Water Block:
EV9503-00 200 PK
EV9503-05 25 PK



Wall Mount Clip:
EV3118-40



Optional Water Block Reset Device:
EV9503-20 200 PK
EV9503-25 25 PK



APPLICATIONS

Coffee Brewers
Espresso Machines
Iced Tea Machines
Small Ice Machines
Boiler Steam
Point-of-Use (POU) Coolers
Undercounter Chillers
Undercounter Instant Hot Water Heaters
Vending Machines

Note: not recommended for use prior to reverse osmosis systems or with Flaker/Nugget ice machines. See Installation Tips below.

INSTALLATION TIPS

Vertical assembly preferred

Not recommended for reverse osmosis (RO) installation as an RO system by nature can produce permeate water for long periods of time which will unnecessarily trip the Water Block

Use of the optional Water Block External Reset Device (EV9503-20) is recommended. Internal reset can be used instead, however, this does require disconnecting the water line

Use of an optional EV3138-61 GHT Adaptor (not shown) is recommended for installation with garden hose type (GHT) connectors

Optional clip (part number EV3118-40) can be used for mounting during installation

BENEFITS • FEATURES

Overflow safety device controls the maximum consumption of water between 1.3 and 13.2 gallons (4.9 and 49.97 L)

Device measures the number of gallons of water that have passed through it; if this quantity exceeds the set value, the Eltek Water Block stops the flow and maintains this safety condition until user intervention

If the water volume does not exceed the set value, the Eltek Water Block mechanically and automatically resets the measured volume and is ready to restart a new measurement cycle

No external energy source required – water simply flows through device

Resistant to chlorine and chloramines damage

OPERATION TIPS

Maximum volume established by 10 setting notches

Every notch increases the set volume by 1.5 +/- gallons (5 +/- liters)

ELTEK™ WATER BLOCK

DISTRIBUTED BY PENTAIR

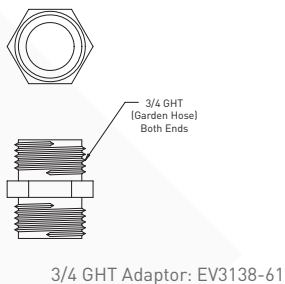
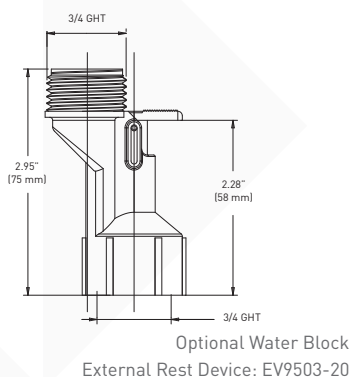
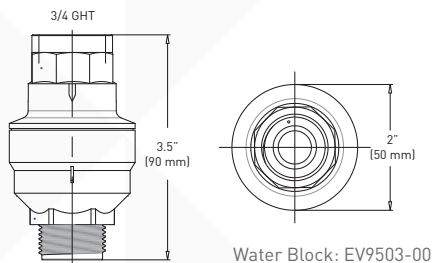

SPECIFICATIONS

Dimensions

3/4" threaded female connection
(North America GHT)

3/4" threaded male connection
(North America GHT)

Pressure Requirements

10 - 125 PSI (0.7 - 8.6 bar)

Ambient Temperature

35 - 140°F (2 - 60°C)

Fluid Temperature

35 - 158°F (2 - 70°C)

Flow Rate

0.53 - 7.9 GPM (2 - 30 Lpm)

Resistance to Bursting

725.19 PSI at 77°F (>50 bar at 25°C)

Related Lifespan

> 79,000 gal (300,000 L)

Electrical Connection

None required

WARRANTY

Eltek warrants that the WATER BLOCK device will be free of defects in materials and workmanship for a period of ninety (90) days from proof of purchase. If a device malfunctions, it must be returned to Eltek for evaluation. If the unit is found to be defective, it will be replaced at no charge. Eltek's warranty does not apply to defects resulting from any action of the purchaser, including but not limited to mishandling, improper adjustment or installation, operation outside recommended design limits, improper repair or maintenance or unauthorized modification. This WARRANTY is VOID if the device shows evidence of having been tampered with or shows evidence of being damaged by the purchaser in any way.

For more information contact Pentair Everpure Technical Service.
Tel: 800.942.1153 (US Only) • 630.307.3000 Main
Email: servicespecialist@pentair.com

FILTRATION & PROCESSING SOLUTIONS

EVERPURE-SHURFLO WORLD HEADQUARTERS, 1040 MUIRFIELD DRIVE, HANOVER PARK, IL 60133 USA • WWW.EVERPURE.COM
800.942.1153 (US ONLY) • 630.307.3000 MAIN • 630.307.3030 FAX • CSEVERPURE@PENTAIR.COM EMAIL

EVERPURE-SHURFLO AUSTRALIA, 1-21 MONASH DRIVE, DANDENONG SOUTH, VIC 3175, AUSTRALIA
011.1300.576.190 TEL • 011.61.39.562.7237 FAX • AU.EVERPURE@PENTAIR.COM EMAIL

EVERPURE-SHURFLO CHINA, 21F CLOUD 9 PLAZA, NO 1118, SHANGHAI, 200052, CHINA
86.21.3211.4588 TEL • 86.21.3211.4580 FAX • CHINA.WATER@PENTAIR.COM EMAIL

EVERPURE-SHURFLO INDIA, GREEN BOULEVARD, B-9/A, 7TH FLOOR - TOWER B SECTOR 62, NOIDA - 201301
91.120.419.9444 TEL • 91.120.419.9400 FAX • INDIACUSTOMER@PENTAIR.COM EMAIL

EVERPURE-SHURFLO EUROPE, PENTAIR WATER BELGIUM BVBA, INDUSTRIEPARK WOLFSTEE, TOEKOMSTLAAN, 30 B-2200 HERENTALS, BELGIUM
+32.(0).14.283.500 TEL • +32.(0).14.283.505 FAX • SALES@EVERPURE-EUROPE.COM EMAIL

EVERPURE-SHURFLO JAPAN INC., HASHIMOTO MN BLDG. 7F, 3-25-1 HASHIMOTO, MIDORI-KU, SAGAMIHARA-SHI KANAGAWA 252-0143, JAPAN
81.(0)42.775.3011 TEL • 81.(0)42.775.3015 FAX • INFO@EVERPURE.CO.JP EMAIL

EVERPURE-SHURFLO SOUTHEAST ASIA, SOUTHEAST ASIA, 390 HAVELOCK ROAD, #04-01 KING'S CENTRE, SINGAPORE 169662
65.6768.5800 TEL • FAX: 65.6737.5149 FAX • CSEVERPURE@PENTAIR.COM EMAIL

All Pentair trademarks and logos are owned by Pentair, Inc. or its affiliates. All other registered and unregistered trademarks and logos are the property of their respective owners. Because we are continuously improving our products and services, Pentair reserves the right to change specifications without prior notice. Pentair is an equal opportunity employer.