



# Prep-Tables with Handsink

## Stainless Steel Prep-Tables



Use your smart phone to scan the above QR code to visit our website:  
[www.bk-resources.com](http://www.bk-resources.com)

### Certifications:

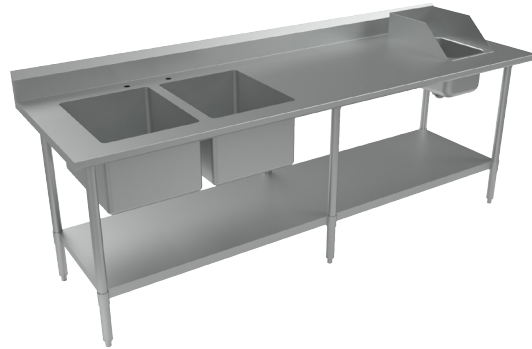

### Features:

- T-304 16 Ga Stainless Steel
- Bowl Size: (2) 16" x 20" x 10"(d) Bowls
- 8" O.C. Deck Mount Faucet Holes
- Handsink Bowl size: 10" x 14" x 10"(d)
- 4" O.C. Deck Mount Faucet Holes
- Stainless Steel Top, Base, and Legs
- 3-10 Day Lead time

### Material:

- T-304 16 ga. Stainless Steel Top & Bowls

Length	Model	Double Sink Side
84"	BKPT-2-3084S-L	Left
84"	BKPT-2-3084S-R	Right
96"	BKPT-2-3096S-L	Left
96"	BKPT-2-3096S-R	Right

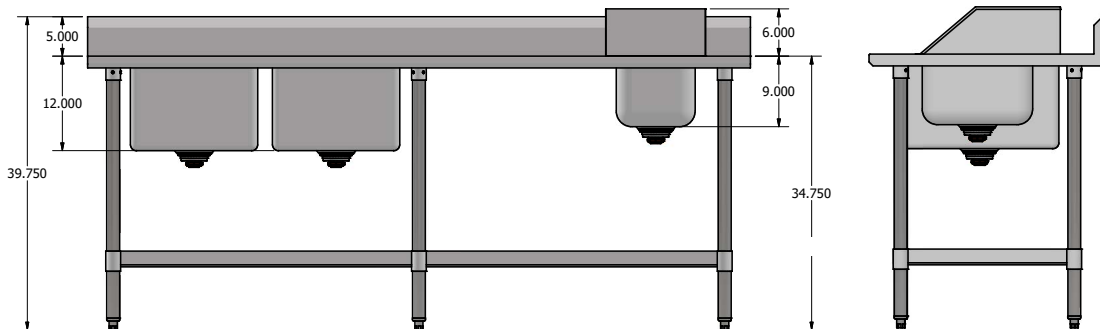
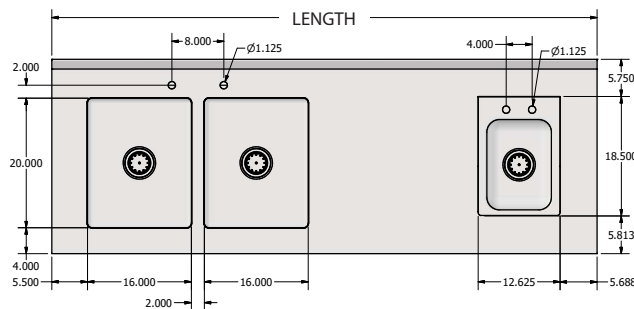

PRODUCT DATA SHEET

BK RESOURCES





# Prep-Tables with Handsink

## Stainless Steel Prep-Tables



Use your smart phone to scan the above QR code to visit our website:  
[www.bk-resources.com](http://www.bk-resources.com)

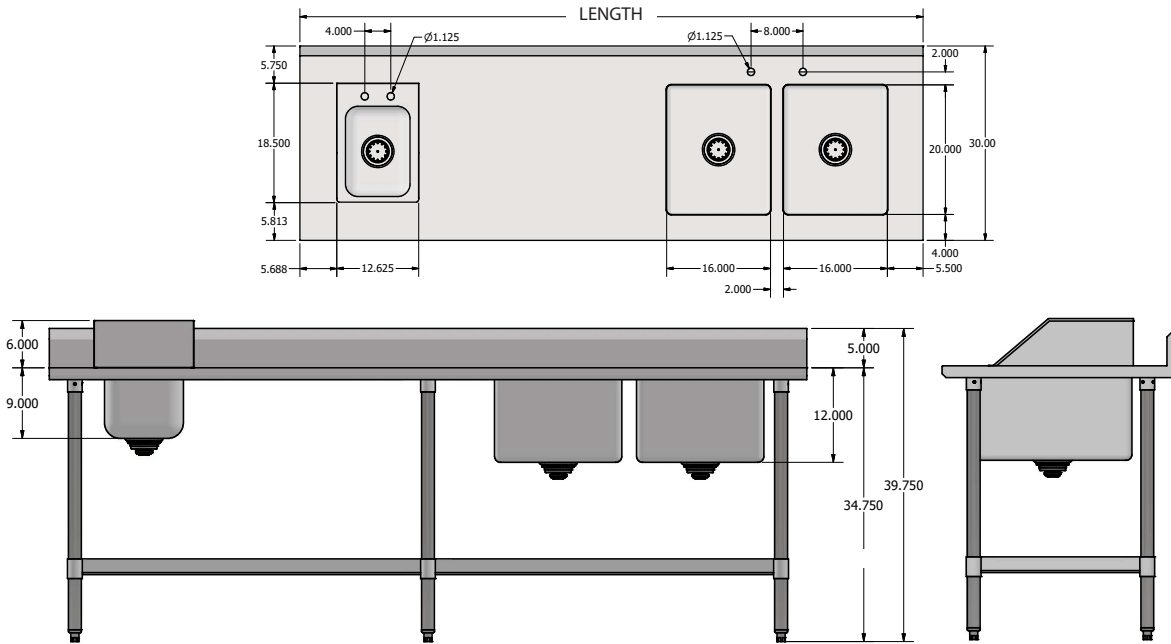

PRODUCT DATA SHEET

BK RESOURCES

