

"EBSS4" ENCLOSED BASE WORK TABLES

14GA Stainless Steel Top w/5" Riser - Sliding Doors

FEATURES:

- 14GA Stainless Steel Flat Top
- Sliding Door Style
- Type 300 Stainless Steel With #4 Polish, Satin Finish
- Top Is Sound Deadened
- Reinforced With 1"x2" Channel Running Entire Length Of Table
- 1-1/2" Stallion Edge On Front And Rear With Side Edges 90 Degree Bend Down For Table Line-Up
- Stainless Steel Base And Undershelf
- Undershelf Is Secured In A Fixed Position, 10" Above Floor
- Shipped Standard Welded Set-Up

SPECIFICATIONS:

- Top: Stainless Steel Tops Are TIG Welded, Exposed Welds Are Polished To Match Adjacent Surface
- Top: 14GA Stainless Steel Type 300 Stainless Steel With #4 Polish, Satin Finish
- Shelf: 18GA Type 300 Stainless Steel, #4 Polish With Satin Finish
- Legs: 1-1/2" Square O.D., 16GA Tubular Stainless Steel
- Panels: 20GA Type 300 Stainless Steel, #4 Polish With Satin Finish
- Feet: 1" Adjustable Stainless Steel Bullet Feet



EBSS4-3072

CERTIFICATIONS:



ACCESSORIES

MODEL	DESCRIPTION
EBRS	Welded Intermediate Shelf - All Sizes

"EBSS4" ENCLOSED BASE WORK TABLES

LENGTH	# OF LEGS	24" WIDTH	WEIGHT (LBS)	30" WIDTH	WEIGHT (LBS)
36"	4	EBSS4-2436	165	EBSS4-3036	180
48"	4	EBSS4-2448	178	EBSS4-3048	195
60"	4	EBSS4-2460	208	EBSS4-3060	227
72"	4	EBSS4-2472	237	EBSS4-3072	258
84"	6	EBSS4-2484	272	EBSS4-3084	296
96"	6	EBSS4-2496	307	EBSS4-3096	334
108"	6	EBSS4-24108	336	EBSS4-30108	366
120"	6	EBSS4-24120	365	EBSS4-30120	398
132"	6	EBSS4-24132	394	EBSS4-30132	430
144"	6	EBSS4-24144	423	EBSS4-30144	462

ALL DIMENSIONS ARE TYPICAL. TOLERANCE +/- .500". JOHN BOOS & CO. RESERVES THE RIGHT TO CHANGE SPECIFICATIONS WITHOUT NOTICE.

DETAILED SPECIFICATIONS

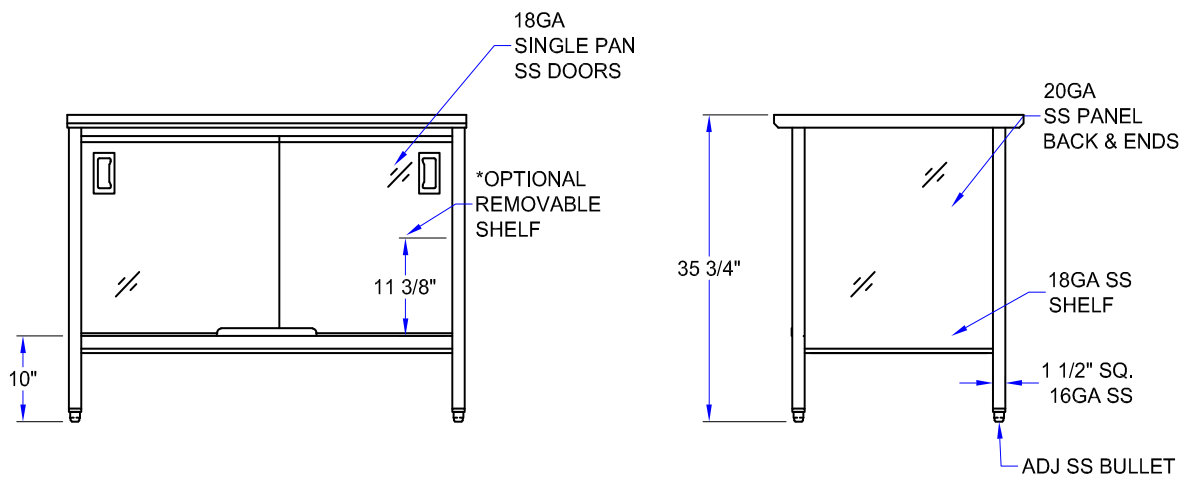
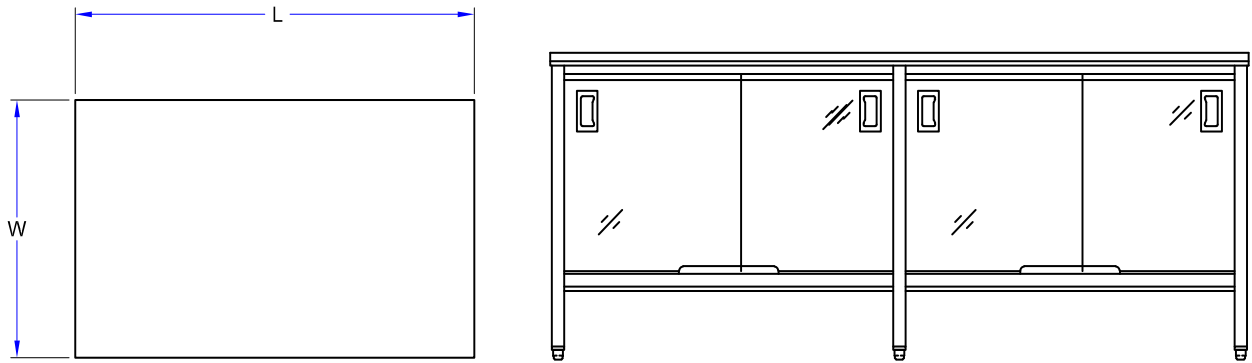

MODEL # STRUCTURE

S = Stainless Steel
 S = Sliding Doors
 EB = Enclosed Base



"EBSS4" ENCLOSED BASE WORK TABLES

LENGTH	# OF LEGS	24" WIDTH	WEIGHT (LBS)	30" WIDTH	WEIGHT (LBS)
36"	4	EBSS4-2436	165	EBSS4-3036	180
48"	4	EBSS4-2448	178	EBSS4-3048	195
60"	4	EBSS4-2460	208	EBSS4-3060	227
72"	4	EBSS4-2472	237	EBSS4-3072	258
84"	6	EBSS4-2484	272	EBSS4-3084	296
96"	6	EBSS4-2496	307	EBSS4-3096	334
108"	6	EBSS4-24108	336	EBSS4-30108	366
120"	6	EBSS4-24120	365	EBSS4-30120	398
132"	6	EBSS4-24132	394	EBSS4-30132	430
144"	6	EBSS4-24144	423	EBSS4-30144	462

ALL DIMENSIONS ARE TYPICAL. TOLERANCE +/- .500". JOHN BOOS & CO. RESERVES THE RIGHT TO CHANGE SPECIFICATIONS WITHOUT NOTICE.