



Data sheet UDBRE048A_V1

Constructive Features

- cooking vessel in stainless steel AISI 304 (bottom thickness 15 mm and wall thickness 2,5 mm) with rounded corner angles and anti-overflowing lip. Vessel with electric tilting on front part
- lid in stainless steel AISI 304 (thickness 20/10), with double cover, with ergonomic handle, reinforced with locking system at 4 points on sliding shafts and lever type control bolts with blocking of opening under pressure. Alimentary silicone gummy gasket with only one jointing point. Balanced by means of gas springs
- self-supporting frame in stainless steel AISI 304 (thickness 30-40/10)
- outer cover in stainless steel AISI 304, fine satin finish (thickness 12-15/10)
- adjustable feet in stainless steel AISI 304 to ensure levelling, with removable cover for cleaning operations
- fast accessibility to the main functional parts (electronic card, fuses, thermostats...) only removing the frontal panels
- protection level IPX5

Functional Features General

- heating by means of armoured elements INCOLOY-800 directly in contact with the steel thermodiffuser plate fixed on the vessel bottom
- temperature control by system with two probes (product/bottom)
- pressure cooking with automatic system for eliminating air from the cooking container (for cooking with saturated steam) and automatic steam condensation after cooking to allow fast and safe lid opening without steam dispersion in the room
- core probe, fixed at the lid, standard
- electronic control by means of multifunctional keyboard with Touch Screen 7" and easy and clear messages
- USB connection to download HACCP data, update the software and load cooking programs
- ability to interrogate the machine using communication protocol MODBUS over RS485 serial interface
- connection for power economizer

Panel Board Functions

- ON/OFF switch
- resistive 7" touch screen
- keys for moving basin
- selection of 7 different cooking modes, with working temperature setting
- cooking type and time setting
- cooking in "Manual" mode
- cooking in "Program" mode
- creating and editing multiphase cooking programs, setting for each phase: type of cooking; cooking parameters (temperature and time), and possibility to insert text messages
- tank water load setting (hot up to 140° F/cold) with automatic liter measurements
- control for tilting and return of cooking tank from Touch Screen or keyboard
- delayed cooking setting with date, time, and programming cycle
- language settings touch Screen
- input of different units of measurement (° C/° F; Liters/gallons; etc)

Display/Signal

- display type of cooking, temperature probes used and set temperature
- heating operating visual alarm
- time to end of cycle display
- tank pressure display
- reporting lid locking and condensing time during cooking under pressure
- display tank out of position for cooking
- signaling tap position, managing water in the tank
- signal of lid and cock position during vat tilting
- thermostat intervention safety signaling
- self-diagnostics

Safety System

- emergency button
- blocking of heating for excess of temperature with manual resettable safety thermostat
- mechanical lid opening lock with tank under pressure
- lid safety valve
- heating interruption during vat tilting

Optionals

- D150 - KIT WHEELS PR/CBT/DBR
- DADE0010 - CLEANING SHOWER DBR...-C
- DAF0180 - STRAINER FOR DBR.180
- DAPF0010 - SET FEET FOR DBR/CBT/PR

Accessories

- DAP01000 - SPATULA FOR OMELETTE

Certificates



Planner

.....

.....

.....

.....

.....

.....

.....

.....

.....

.....

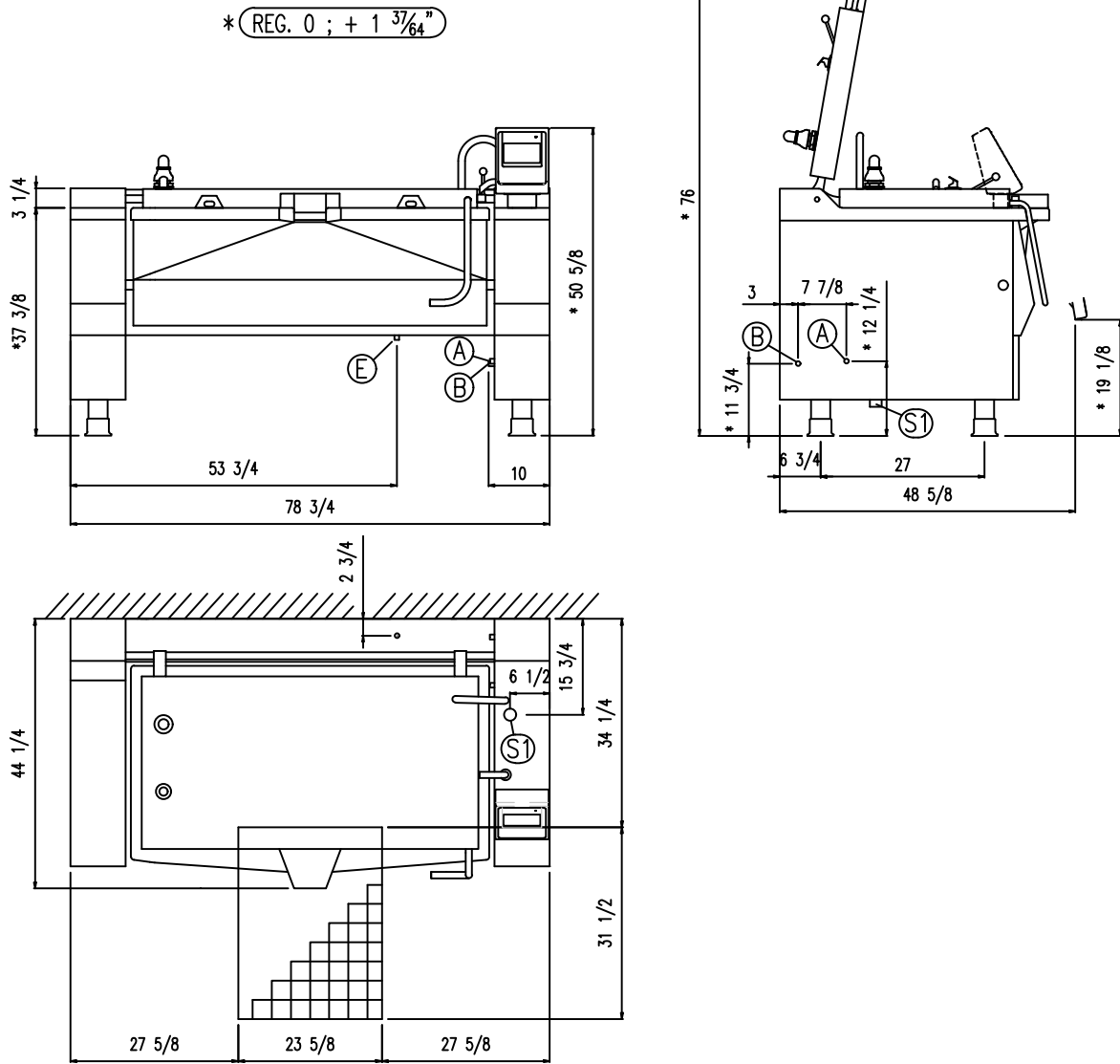

Dimensions weights and capacities

Width	78 3/4 inch	Vessel width	55 1/2 inch	Capacity	48 gal
Depth	44 1/4 inch	Vessel depth	25 5/8 inch	Cooking vessel surface	1348 inch ²
Height	50 5/8 inch	Vessel height	16 1/2 inch	Weight	1268 lb

Water connection

Water pressure	25-50 PSI	Cold water inlet (B)	3/4"	Hot water inlet (A)	3/4"
Condensate drain pressure (S1)	1"				

Electrical connection

STD Voltage (E)	3 PHASE 220-240 V~ 60Hz	Electric power	26.40 kW	Current	71.5 A
OPT Voltage (E)	3 PHASE 208V 3 ~ 60Hz	Electric power	26.40 kW	Current	82.5 A