

E-20 PREFILTER SYSTEM

PREFILTER SYSTEM FOR FOODSERVICE APPLICATIONS

E-20 Prefilter System: EV9795-90
EC210 Prefilter Cartridge: EV9534-26



APPLICATIONS

- ◆ Foodservice Applications Requiring Prefiltration
- ◆ High Sediment Areas

FEATURES • BENEFITS

- ◆ Filters out larger dirt and rust particles
- ◆ Durable slim bowl design makes cartridge change outs easy to handle
- ◆ Extends the life of primary filter cartridges
- ◆ 20" bowl design accepts most 20" drop in cartridges
- ◆ Tightly spun Pentair[®] Everpure[®] EC210 sediment cartridge delivers 10-micron nominal filtration

INSTALLATION TIPS

- ◆ Choose a mounting location suitable to support the full weight of the system when operating.
- ◆ Make sure to properly lubricate o-ring prior to use.
- ◆ Use 3/4" water line (optional reducer bushings included).
- ◆ Install vertically with bowl hanging down.
- ◆ Allow 2 1/2" (6.35 cm) clearance below the cartridge for easy cartridge replacement.

OPERATION TIPS

- ◆ Inspect EC210 cartridge periodically to determine dirt load.
- ◆ Replace EC210 cartridge when dirt has penetrated through to the inner core of the cartridge.
- ◆ Do not exceed service flow rate.
- ◆ Inspect o-ring during each cartridge change. Lubricate and/or replace if necessary.

SIZING

- ◆ Service Flow Rate:
Maximum 8.0 gpm (30.3 Lpm)

E-20 PREFILTER SYSTEM

EV9795-90

E-20 Prefilter System: EV9795-90
EC210 Prefilter Cartridge: EV9534-26

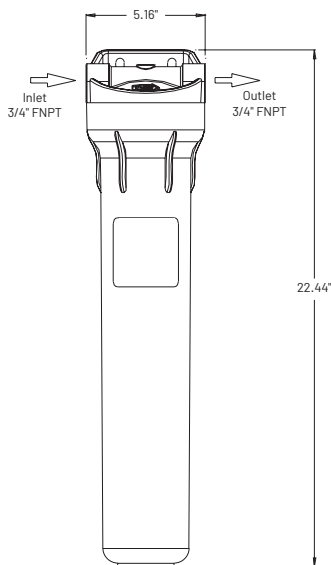

SPECIFICATIONS

- ◆ **Service Flow Rate**
Maximum 8.0 gpm (30.3 Lpm)
- ◆ **Pressure Requirements**
10 - 125 psi (0.7 - 8.6 bar), non-shock
- ◆ **Temperature**
35 - 100°F (2 - 38°C)
- ◆ **Overall Dimensions**
22.44" H x 5.16" W x 5.5" D
(56.9 cm x 13.1 cm x 13.9 cm)
- ◆ **Inlet Connection** 3/4"
- ◆ **Outlet Connection** 3/4"
- ◆ **Operating Weight**
8 lbs (3.6 kgs)
- ◆ **Shipping Weight:**
6 lbs (2.7 kgs)
- ◆ **Electrical Connection**
None required



WARRANTY

Everpure water treatment systems by Pentair (excluding replaceable elements) are covered by a limited warranty against defects in material and workmanship for a period of five years after date of purchase. Everpure replaceable elements (filter cartridges and water treatment cartridges) are covered by a limited warranty against defects in material and workmanship for a period of one year after date of purchase. See printed warranty for details. Pentair will provide a copy of the warranty upon request.

The contaminants or other substances removed or reduced by this drinking water system are not necessarily in your water. Do not use with water that is microbiologically unsafe or of unknown quality without adequate disinfection before or after the system.

Since the conditions under which our products may be used are beyond our control, we cannot accept any liability with respect to the improper installation, application and/or use of our products.



World Headquarters
1040 Muirfield Drive
Hanover Park, IL 60133
United States
800.942.1153 (US Only)
630.307.3000 Main
cseverpure@pentair.com

Australia
1-21 Monash Drive
Dandenong South, Vic 3175
Australia
011.1300 576 190 Tel
au.everpure@pentair.com

China
21F Cloud 9 Plaza, NO 1118
Shanghai, 200052
China
86.21.3211.4588 Tel
china.water@pentair.com

India
Boulevard, B-9/A,
7th Floor - Tower B Sector 62
Noida - 201301
91.120.419.9444 Tel
indiacustomer@pentair.com

Europe
Pentair Water Belgium BVBA
Industriepark Wolfstee,
Toekomstlaan 30,
B-2200 Herentals
Belgium
+32.(0)14.283.504 Tel
sales@everpure-europe.com

Japan Inc.
Hashimoto MN Bldg. 7F,
3-25-1 Hashimoto, Midori-ku,
Sagamihara-shi
Kanagawa 252-0143
Japan
81.(0)42.775.3011 Tel
info@everpure.co.jp

Southeast Asia
390 Havelock Road,
#04-01 King's Centre
Singapore 169662
65.6768.5800 Tel
cseverpure@pentair.com

§ Pentair trademarks and logos are owned by Pentair plc or its affiliates. For a detailed list of where Pentair trademarks are registered, please visit www.pentair.com/en/registrations.html. Third party registered and unregistered trademarks and logos are the property of their respective owners. Because we are continuously improving our products and services, Pentair reserves the right to change specifications without prior notice. Pentair is an equal opportunity employer.