



EV9608-10

# 2JT Flushing/Sanitizing

Ultimate flushing tool for Everpure systems



4JT Cartridge: EV9608-00

2JT Cartridge: EV9608-10

## BENEFITS

The preferred way to introduce ScaleKleen™ scale remover or other sanitizing agents, such as bleach into all water-using appliances and vending machines

Fits into existing Everpure filter heads

Eliminates the need for difficult component disassembly

It's an easy and convenient tool to help you clean and maintain your equipment

Approved by NAMA

## INSTALLATION TIPS

This cartridge must be installed and used according to the Installation and Use instructions provided with the product

## OPERATION TIPS

For use in Everpure quick change filter heads

## APPLICATION/SIZING

Model 4JT can size is 16 inches in length

Model 2JT can size is 10 inches in length

## 2JT Flushing/Sanitizing

### SPECIFICATIONS

Overall Dimensions:  
10"H x 4"W x 4"D

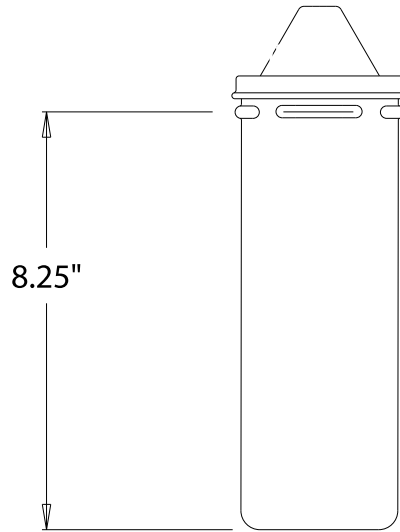

### WARRANTY

Everpure water treatment systems (excluding replaceable elements) are covered by a limited warranty against defects in material and workmanship for a period of five years after date of purchase. Everpure replaceable elements (filter cartridges and water treatment cartridges) are covered by a limited warranty against defects in material and workmanship for a period of one year after date of purchase. See printed warranty for details. Everpure will provide a copy of the warranty upon request.

**EVERPURE®**

EVERPURE, INC.  
2375 Sanders Road  
Northbrook, IL 60062  
Toll Free (800) 323-7873  
Tel (847) 205-6000  
Fax (800) 942-0081  
<http://www.everpure.com>

*In Europe:*  
N.V. EVERPURE (EUROPE) S.A.  
Geldenaaksebaan 478  
B-3001 Heverlee  
Belgium  
Tel 32-16-401191  
FAX 32-16-402691

*In Japan:*  
EVERPURE JAPAN, INC.  
1-8-19, Tsumada Kita,  
1-Chome, Atsugi City  
Kanagawa Ken 243-0812  
Japan  
Tel 81-462-23-6563  
FAX 81-462-21-6775

Everpure, Inc.  
2375 Sanders Road  
Northbrook, IL 60062  
Phone: 800-323-7873 Fax: 800-942-0081