

# Specification Sheet

## Short Form Specifications

BlendPort<sup>®</sup> Glass Froster, model \_\_\_\_\_.  
 Foamed-in-place high density polyurethane insulation. Stainless steel countertop with 1/2" edge. Lockable stainless steel sliding cover(s) with extruded pull handles. Cabinet exterior features wear-resistant black vinyl. User-friendly well design allows easy reach to interior base. Painted aluminum interior with stainless steel floor. Removable interior shelving. Forced-air cooling. Factory balanced refrigeration system holds at 0°F. Automatic defrost system. Condensing system slides out for ease of maintenance. Split shelf design. 33 1/2" overall height.



model #BPR-GF-25 glass froster

Item No.:	_____
Project No.:	_____
S.I.S. No.:	_____

## Glass Frosters

### MODELS:

- BPR-GF-25
- BPR-GF-50

### Design & Construction Features

- Stainless steel countertop with 1/2" upturn and lockable stainless steel sliding cover.
- Black vinyl-clad cabinet.
- Easy-to-reach large-capacity well with painted aluminum sides and stainless steel floor.
- Removable perforated shelving inside cabinet.
- 1" extruded bumpers on rear of cabinet.
- Condenser unit slides out from behind front grill.
- 120-volt, 60-cycle, single-phase electricity
- 90" cord with NEMA 5-15P plug.
- Self-contained refrigeration holds temperature at 0°F.
- One year parts and labor warranty and five year compressor warranty.

Item No.:	_____
Project No.:	_____
S.I.S. No.:	_____

# Glass Frosters

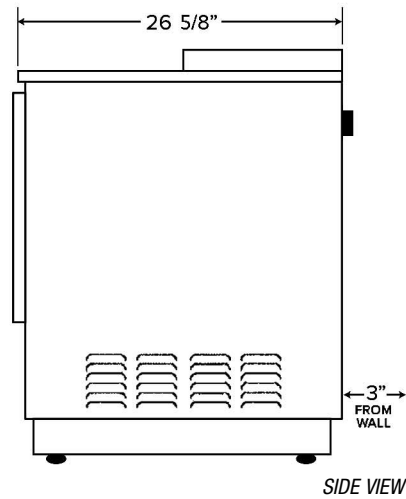
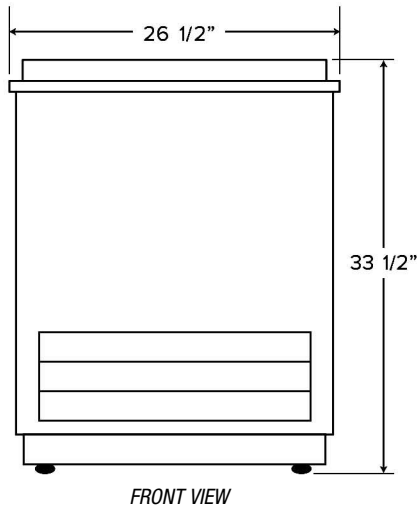
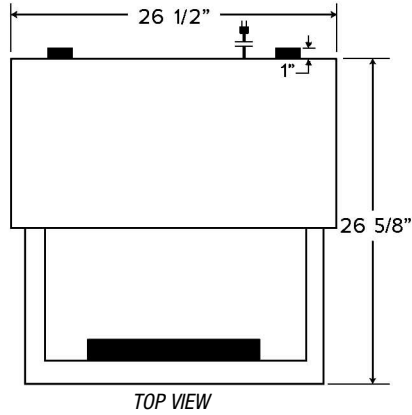

(model #BPR-GF-25 shown)

width		length		height		# of sliding covers	capacities		electrical data*	weight	model #
in.	mm	in.	mm	in.	mm		8" mugs	10" Steins			
26 5/8"	676	26 1/2"	673	33 1/2"	851	1	90	85	1/3-HP, 120V	196 lbs.	<b>BPR-GF-25</b>
26 5/8"	676	49 1/2"	1257	33 1/2"	851	2	250	240	1/3-HP, 120V	323 lbs.	<b>BPR-GF-50</b>

\* Units are 60-cycle single-phase.

All units feature one-year parts and labor warranty and five-year compressor warranty.

## BlendPort<sup>®</sup>

An Eagle Group Company  
100 Industrial Boulevard, Clayton, DE 19938-8903 USA  
Phone: 800-441-8440 • Fax: 302-653-2065

Printed in U.S.A.  
©2023 by Eagle Group  
Rev. 03/23

Although every attempt has been made to ensure the accuracy of the information provided, we cannot be held responsible for typographical or printing errors. Information and specifications are subject to change without notice. Please confirm at time of order.