

# BIZERBA

## Food Service

### MARINE VESSEL MEAT SLICER

... GSP HD USPH-VSP-220V - automatic safety slicer ...

**Heavy Duty Marine Meat Slicer - Safety illuminated dial!** U.S. Patented Safety Illumination US 9,827,689 B2

- USPH Standard for Vessel Sanitation Program - 2011 Construction Guidelines
- Marine Fasteners, low profile, non-slotted, non-corroding easy to clean fasteners on food-contact surfaces and in splash zones
- Marine Vessel Voltage: 220Volt / 60 Hz / 1-Phase, 6' foot cord, **Euro power plug**
- Variable 3-Speed, automatic drive system
- 3 Stroke Lengths, easily adapts to changing menu
- Energy Efficiency: Emotion intelligent motor control, motor adapts its performance to the resistance of the product, 255 r.p.m.
- High Yield: Operating time, designed for permanent operation
- High Yield: Unique carriage-shifting design allows for the smallest end pieces, increased product yield
- High Yield: Food fence holds product in place during automatic slicing, included
- High Yield: Widest product carriage for increased capacity
- High Yield: Heavy-duty, 3 lb. blade knife cover
- High Yield: Debris deflector, permanently mounted, included
- High Yield: Precision machined pencil-point-groves on gauge plate, blade cover and carriage to reduce friction, better looking product
- Safety Interlock: No-volt release
- Safety Interlock: Shut off in slice thickness knob
- Safety Interlock: Adjustable blade shut off settings: 15, 30, 45 seconds or off
- Safety Interlock: Carriage and gauge plate lock during the cleaning process
- Safety Interlock: Forced start with slice thickness knob below zero
- Operator Safety: Slicer installation, start-up and training, included
- Operator Safety: Illuminated index slicing dial, at-a-glance machine status:
  - 1) green - safe for cleaning
  - 2) flashing red - blade exposed, close gauge plate before cleaning
  - 3) solid red - proceed with caution, ready to slice
- Operator Safety: Green push-handle on carriage, safe slicing
- Operator Safety: Red lift arm handle, reminds operator to use caution
- Operator Safety: 3.5"W (90mm) x 9.13"H x 2.6"D thumb guard wall for maximum protection
- Operator Safety: 360° blade enclosure, no top-gaps in blade ring-guard
- Operator Safety: Zero blade exposure during the cleaning process
- Operator Safety: Front mounted controls
- Operator Safety: Rear mounted lift arm with largest and easiest to use remnant holder with 306 holding points, removable for cleaning, dish-machine safe
- Operator Safety: The ability to adjust both the speed and the stroke of the carriage "on-the-fly" will speed up your operation
- Operator Safety: Servo-motor provides assistance to operator by decreasing slicing effort, reduces operator fatigue during manual slicing mode
- Operator Safety: Low profile carriage for easy loading of heavy product
- Operator Safety: Side lift-arm for easy cleaning under slicer
- Food Safety: One piece anodized aluminum construction
- Food Safety: Non-removable carriage system for faster cleaning and sanitizing
- Food Safety: Double-sided seal between blade knife and housing, no gap for food to collect, better hygiene
- Food Safety: UL157 dairy grade seals and gaskets used to seal against water and food debris, no silicone used under seals, better hygiene
- Food Safety: Liquid and debris diversion from all control surfaces
- Food Safety: Remote blade sharpener does not collect food debris during operation and is dishwasher safe for improved safety and hygiene
- Food Safety: One piece carriage with seamless thumb guard for highest hygiene standards, no slotted-screw heads on thumb guard
- Food Safety: Enclosed base and under carriage, easy to clean, best hygiene
- One Year Warranty: On-site, labor and parts

#### Best blade in the industry

The unique design of our blade produces clean and consistent slices. The hardness results in a long lasting sharp edge. The life of the blade is dramatically longer than the competition. Our standard blade is the hardest, thinnest, largest, straightest blade in the industry.

- 13" diameter, chromium coated hard alloy
- 60-62 Rockwell hardness at the edge
- Accurate slicing on meats and even the most demanding cheese products over a wide temperature range



Gauge plate closed, safe for cleaning - green.



Gauge plate open and motor running, ready to slice - solid red.



Model #: GSP HD USPH-VSP-220V |

C.S.I. Division 11 | Section 4000

Project Name: \_\_\_\_\_ AIA # \_\_\_\_\_

Location: \_\_\_\_\_ SIS # \_\_\_\_\_

Item Number: \_\_\_\_\_

Quantity: \_\_\_\_\_

# BIZERBA

## Food Service

### Emotion<sup>(R)</sup> Technology - Variable Frequency Drive Motor

- 220V, with Euro power plug
- 60 Hz | 1-phase AC current
- Frequency of nominal current 1.4 A
- Power consumption 0.240 kW
- Energy savings up to 60%
- Idle-running requires 45% less energy
- Stand-by mode 0.0 kW energy usage
- Cutting performance adapts to cutting resistance of the product
- Less heating of machine, cooler food-zone surface

#### Blade diameter

- 13" (330 mm)

#### Blade speed

- 255 r.p.m.

#### Max. produce size

- Round: 7.95" (202 mm)
- Height: 4.96" (126 mm)
- Width: 11.42" (290 mm)

#### Strokes per minute

- Full: 30-40-50
- Mid: 35-48-58
- Short: 60-68-75

#### Slice thickness

- 0-0.94" (0-24 mm), infinitely variable

#### Thumb-guard rear wall

- 3.5"W x 11.13"H x 2.6"D (90 x 235 x 67 mm)

#### Gravity-feed slicing carriage

- 40° inclined gravity feed

#### H - Carriage inclination

- Carriage inclined 25° towards operator
- Carriage height positioned towards center of blade

#### Noise control drive system

- ~68.5 dB level - a 20% reduction in decibel pollution

#### Installation area

- (L x W) 20.94" x 17.48" ( 532 x 444 mm)

#### External dimensions

- (L x W x H) 28.5" x 22.48" x 24.67" ( 724 x 571 x 627 mm)

#### Operating area

- (L x W) 31.73" x 35.39" ( 806 x 899 mm)

#### Food Safety - Ingress Protection type

- IP Solids level 3 | Liquids level 3

#### Weight of machine

- 122 lbs, 55 kg

#### Shipping Details & Dimensions

- Total Shipping Dimensions (L x W x H): 32.5" x 27.8" x 32" (826 x 706 x 813 mm)
- Total Shipping Weight: 150 lbs, 68 kg
- Cubic: Ft. 16.89, 0.48 m
- Density: 8.88 lb/cubic ft, 142.6 kg/cubic m

#### Additional equipment

- Vegetable chute 7" dia x 12"L (178 x 350 mm), 3 lb ( 1.36 kg) easy-gliding stomper
- 2"H ( 51 mm) Product fence
- Equipment Stand
- Extended Warranty
- 13" (330 mm) Grooved Cheese Blade



USPH Marine Standard. Fasteners: low profile, non-slotted, NON-CORRODING, and easy-to-clean fasteners on FOOD CONTACT SURFACES and in splash zones



#### Remote sharpener



#### Warranty

The GSP HD Safety Slicer carries a one-year, on-site parts and labor warranty against any flaws in materials and workmanship. This period begins with the date of purchase and, provided the unit is used properly in accordance with our instructions, is in full effect for one year from that date. Any work to be performed under this warranty must be performed between the hours of 8:00 a.m. and 4:30 p.m. local time, Monday to Friday. Bizerba will not pay overtime charges for work performed other than during normal business hours. Accessories have a 30-day replacement or repair warranty for the period beginning on the date of purchase. Damages incurred in transit or from installation error, accident, alteration or misuse are not covered. Transit damages should be reported to the carrier immediately. Bizerba shall not be liable for any consequential, compensatory, incidental, or special damages. All warranty work must be performed by a factory authorized Bizerba Representative.

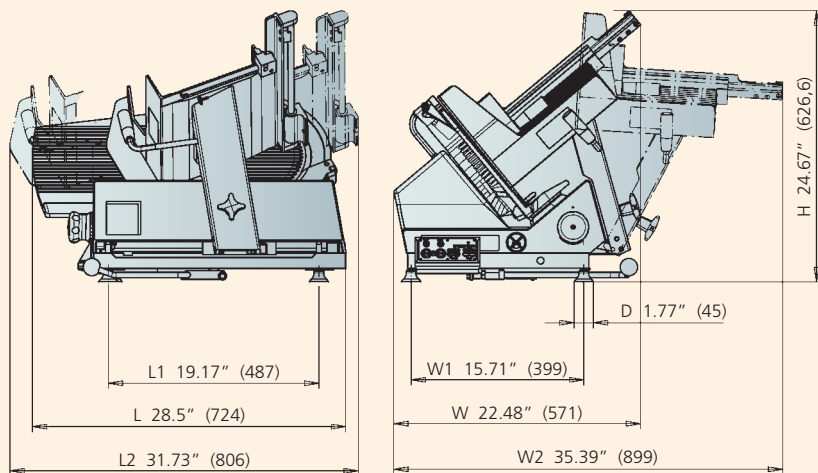

### Members of the Bizerba Group

Bizerba GmbH & Co. KG  
 Wilhelm-Kraut-Straße 65  
 72336 Balingen  
 Germany  
 Tel. +49 7433 12-0  
 Fax +49 7433 12-2696  
 marketing@bizerba.de  
 www.bizerba.com

Bizerba USA Inc.  
 1804 Fashion Court  
 Joppa, MD 21085  
 USA  
 Tel. Office +1 732 565-6000  
 Tel. Service +1 732 565-6001  
 Fax +1 732 819-0429  
 us.foodservice@bizerba.com  
 www.bizerba.com

Bizerba Canada Inc.  
 6411 Edwards Blvd.  
 Mississauga, Ontario L5T2PT  
 Canada  
 Tel. +1 888 240-3722  
 French Tel. +1 877 699-2199  
 Fax +1 905 816-0497  
 ca.info@bizerba.com  
 www.bizerba.ca

Bizerba de México, S.A. de  
 C.V. Av. Rio Mixcoac No. 157  
 Colonia Florida  
 01030 México, D.F.  
 México  
 Tel. +52 55 5663-1397  
 Fax +52 55 5663-1296  
 contacto@bizerba.com.mx  
 www.bizerba.com.mx

