

JOB:
ITEM:
QTY:

BULK CART – FRAME & TUBS

APPLICATION:

These multi-use carts are ideal for food preparation, pack out, storage and ice. They are available in three different sizes. Removable tubs are constructed of sanitary, non-rusting, washable, and steam cleanable polyethylene.

MATERIAL:

Framework is constructed out of 1"x1"x.070" wall tubing. Uprights are reinforced with a channel to help prevent breakage from the stem type casters.

CASTERS:

These carts come equipped with four 5" stem type swivel casters.

GUARANTEE:

These carts carry a **Lifetime Guarantee** against rust and corrosion and also carry a **Five-Year Guarantee** against workmanship and material defects.



Model #1275

Model #96699



Phone: 800-255-0104
Fax: 877-877-7687
www.newageindustrial.com
sales@newageindustrial.com

New Age Industrial reserves the right to modify or make changes at any time without notice to materials and specifications.

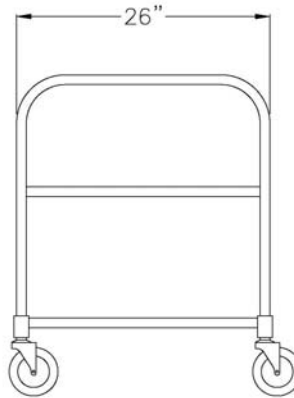
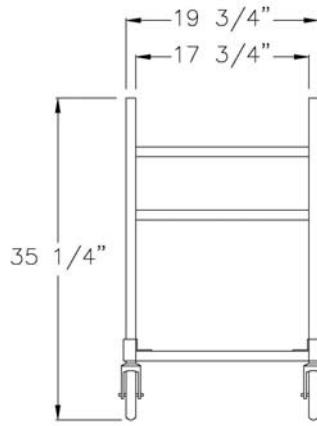

Model #1275

Model No.	Size-W	Size-H	Size-D	Bushel Cap.
1275	19 3/4"	35 1/4"	26"	2 1/4
96699	20"	36"	30"	6
96936	22"	32"	39 1/2"	8
Replacement Tubs (Above Units Come W/Tubs)				
0300	19 1/4"	13 3/4"	26"	2 1/4
0363	20"	21"	30"	6
0360	21 1/2"	21"	40"	8



Phone: 800-255-0104
 Fax: 877-877-7687
www.newageindustrial.com
sales@newageindustrial.com

New Age Industrial reserves the right to modify or make changes at any time without notice to materials and specifications.