

- Secure thru-the-wall shanks from loosening and rotating
- SpinStop™ D shanks lock into the patented D-hole strip
- Effective way to eliminate a loose shank service call
- Pair with corresponding wall mount drip tray

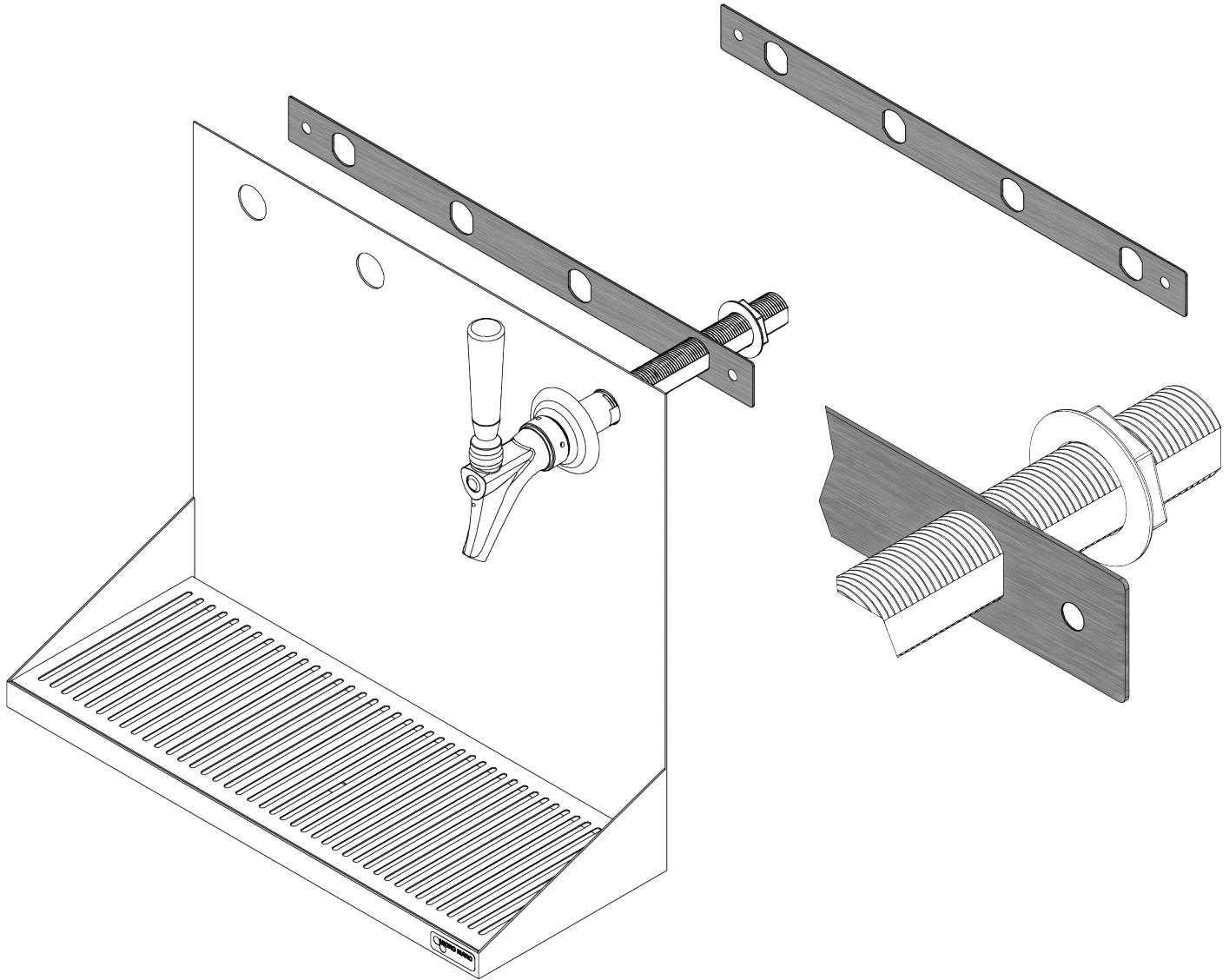

Part No.	LENGTH	SHANK HOLES	HOLE CENTERS
<input type="checkbox"/> DP-WM-MS4-3	11 3/4"	4	3"
<input type="checkbox"/> DP-WM-MS4-3.5	13 3/4"	4	3 1/2"
<input type="checkbox"/> DP-WM-MS4-4	15 3/4"	4	4"

Dimensions

