

REMOTE POWER PACK - AIR COOLED



PREMIUM - 1 PUMP - 3,600 BTUs

- Engineered by beer-industry experts for performance and value.
- Digital thermostat for accurate glycol bath temperature.
- Expanded urethane foam insulates cabinet to maintain glycol temperature and minimize condensation.
- Exterior sight glass to verify glycol bath level.
- Anti-vibration pads reduce motor noise.
- Remote condenser for accessibility.
- Fan control switch and crank case heater included.
- Pump down refrigeration system.



Glycol Bath, Pump & Motor
(cover included)



Remote Condenser Unit
(cover included)

MMPP4302-R

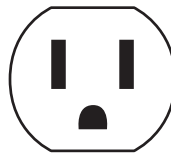

5-15P



Part No.	Description	Shipping Weight
 MMPP4302-R	Remote condenser, air cooled power pack, 1 pump and motor	80 kg 175 lbs

Operating Performance

Compressor	1/2 HP
BTU per hour	3,600
Plug Type (NEMA #)	5-15P
Voltage	115
Running Amps*	15.4A
Refrigerant	R-134a

Charge	TBD
Refrigerant Running Pressure	18 (low) 140 (high)
Bath Capacity	43.5 litre (11.5 gallons)
Pump Type	Rotary Vane
Push In Connector	12.7mm (1/2") O.D.

*Two circuits – one for the condensing unit and one for the bath.

Dimensions

REMOTE CONDENSING UNIT

Remote Power Packs must be installed by a qualified refrigeration technician, copper line set, drier, sight glass and refrigerant must be provided by installer. The condensing unit needs to be hard wired and the bath has a cord and plug.

Maximum distance from bath to compressor is 50 ft.

DIMENSIONS IN INCHES			
L	W	H	CH
24.0	19.4	16.2	15.6

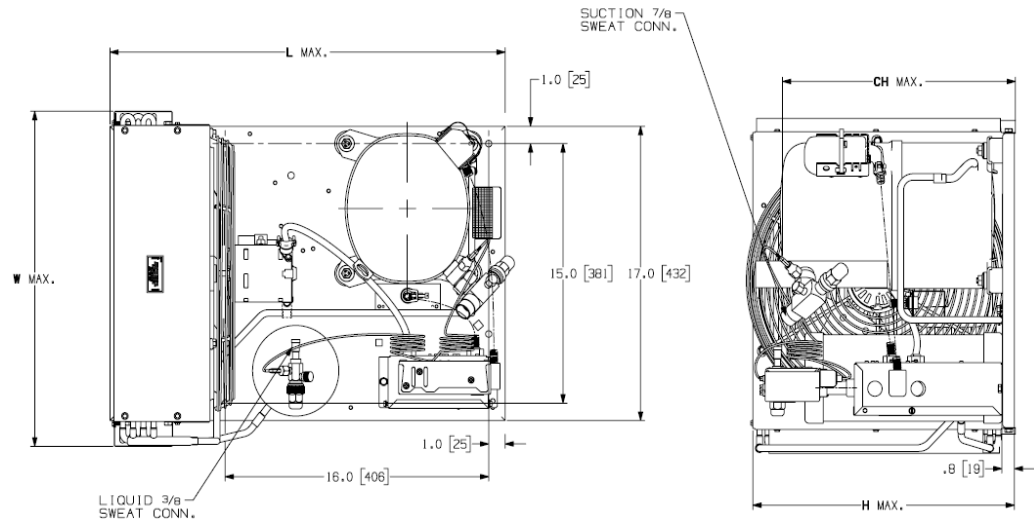

GLYCOL BATH, PUMP & MOTOR

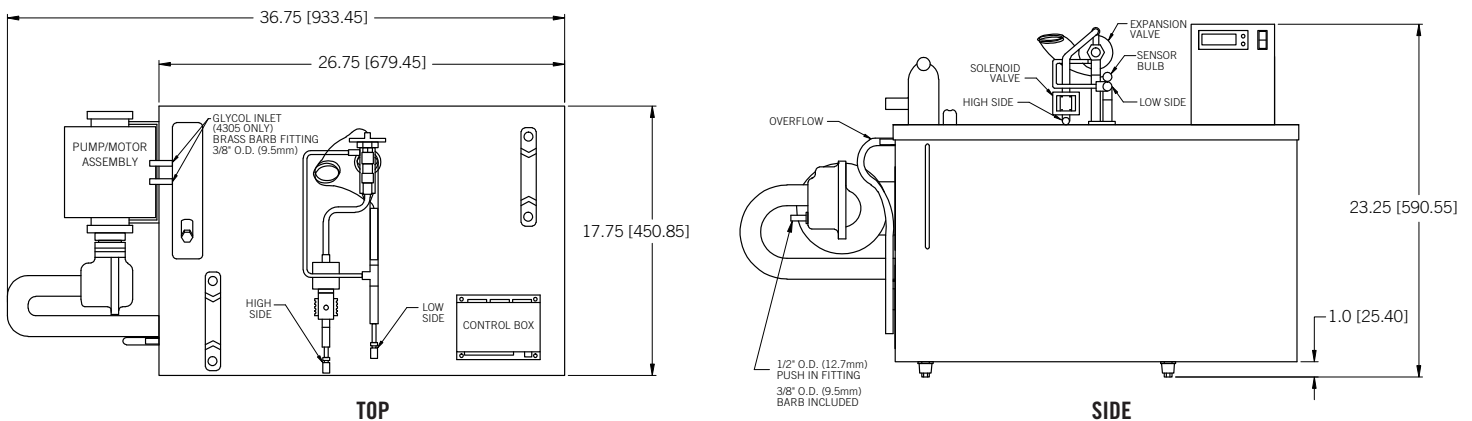

Toll-Free: 1-866-327-4159
www.micromatic.com

West
 19791 Bahama St.
 Northridge, CA 91324
 Tel. (818) 701-9765
 Fax. (818) 701-9844

Central
 10726 North Second St.
 Machesney Park, IL 61115
 Tel. (815) 968-7557
 Fax. (815) 968-0363

Southeast
 15111 Dispense Ln.
 Brooksville, FL 34604
 Tel. (352) 799-6331
 Fax. (352) 796-2429

Northeast
 4601 Saucon Creek Rd.
 Center Valley, PA 18034
 Tel. (610) 625-4464
 Fax. (610) 625-4466