

# "ABPR-S-Z" ALUMINUM MOBILE PAN RACKS

## *Side Load - Nesting Rack Design*

**FEATURES:**

- 6063 Aluminum 1" Square Tubing
- Bolted Diagonal Cross Rails
- Nest Multiple Racks Together
- 3" Spacing - 20 Pan Capacity
- 5" Casters
- Knock Down - Bolt Together Construction

**SPECIFICATIONS:**

- Rack: 6063 Aluminum - MIG Welded

**CERTIFICATIONS:**



NESTING RACKS



ABPR-1820-ZNS

### "ABPR-S-Z" ALUMINUM MOBILE PAN RACKS

MODEL	SIZE (L X W X H)	WT. LIMIT/RACK (LBS)	WT. LIMIT/PAN (LBS)	WEIGHT (LBS)
ABPR-1820-ZNS	28-1/2"x18"x71"	300	10	30

ALL DIMENSIONS ARE TYPICAL. TOLERANCE +/- .500". JOHN BOOS & CO. RESERVES THE RIGHT TO CHANGE SPECIFICATIONS WITHOUT NOTICE.

# DETAILED SPECIFICATIONS

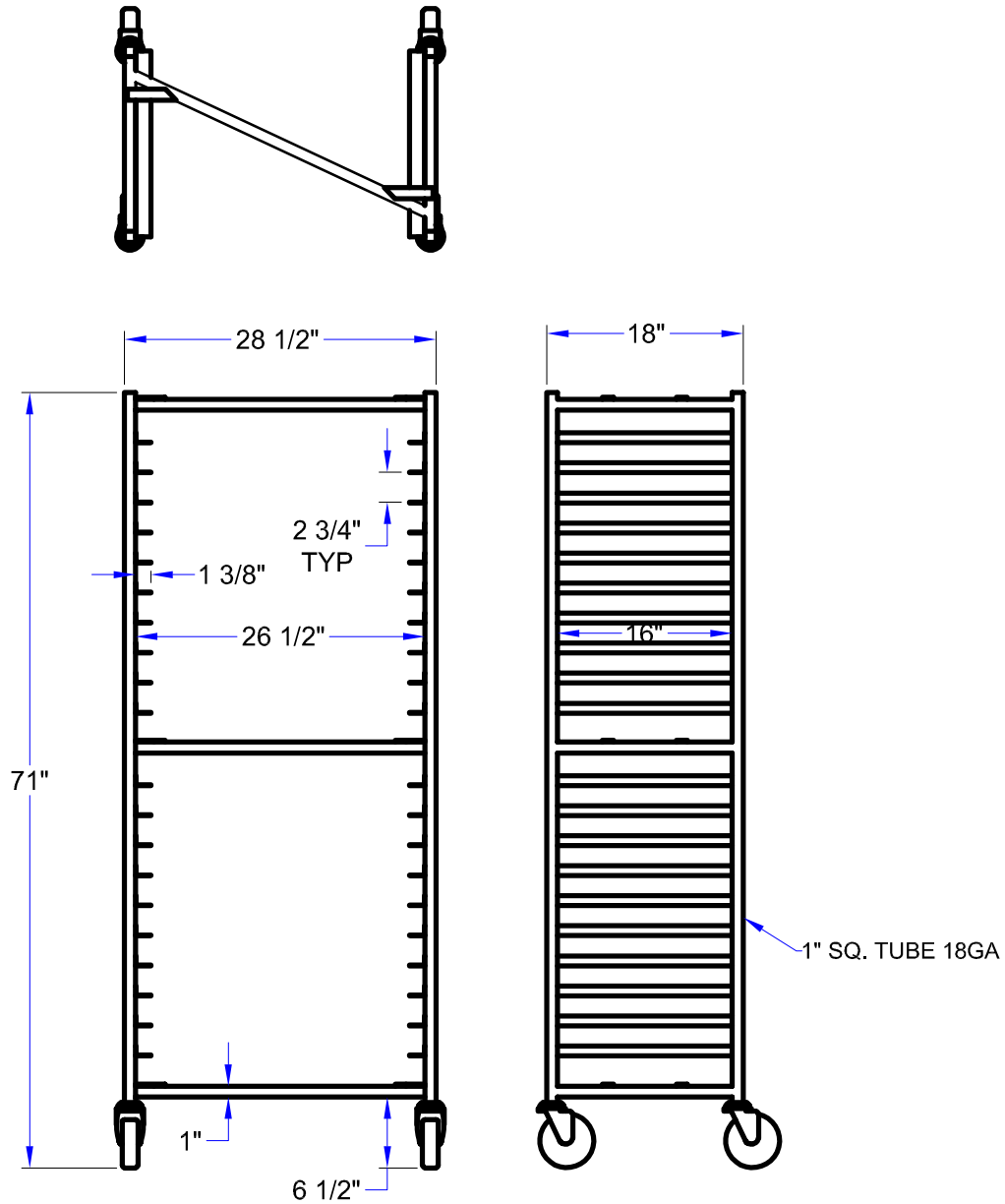

## "ABPR-S-Z" ALUMINUM MOBILE PAN RACKS

MODEL	SIZE (L X W X H)	WT. LIMIT/RACK (LBS)	WT. LIMIT/PAN (LBS)	WEIGHT (LBS)
ABPR-1820-ZNS	28-1/2"x18"x71"	300	10	30

ALL DIMENSIONS ARE TYPICAL. TOLERANCE +/- .500". JOHN BOOS & CO. RESERVES THE RIGHT TO CHANGE SPECIFICATIONS WITHOUT NOTICE.