

**BLOOMFIELD INDUSTRIES**

10 Sunnen Drive  
St. Louis, MO 63143  
telephone: 314-678-6336  
fax: 314-781-2714  
www.wellsbloomfield.com



*Model 8740 Brewer*

**OWNERS MANUAL  
for**

**ICED TEA  
BREWING SYSTEM**

**MODEL**

**8740**

**Includes:**

- Installation**
- Operation**
- Use & Care**
- Servicing Instructions**

## WARRANTY STATEMENT

All electrical equipment manufactured by WELLS BLOOMFIELD, LLC is warranted against defects in materials and workmanship for a period of one year from the date of original installation or eighteen (18) months from the date of shipment from our factory, whichever comes first, and is for the benefit of the original purchaser, except that:

- a. airpots carry a 30 day parts warranty only.
- b. dispensers; i.e., tea and coffee carry a 90 days parts warranty only, excludes decanters.

THE FOREGOING OBLIGATION IS EXPRESSLY GIVEN IN LIEU OF ANY OTHER WARRANTIES, EXPRESSED OR IMPLIED, INCLUDING ANY IMPLIED WARRANTY OF MERCHANTABILITY OR FITNESS FOR A PARTICULAR PURPOSE, WHICH ARE HEREBY EXCLUDED.

WELLS BLOOMFIELD, LLC SHALL NOT BE LIABLE FOR INDIRECT, INCIDENTAL OR CONSEQUENTIAL DAMAGES OR LOSSES FROM ANY CAUSE WHATSOEVER.

This warranty is void if it is determined that upon inspection by an Authorized Service Agency that the equipment has been modified, misused, misapplied, improperly installed, or damaged in transit or by fire, flood or act of God.

It also does not apply if the serial nameplate has been removed or unauthorized service personnel perform service. The prices charged by Bloomfield Industries for its products are based upon the limitations in this warranty. Seller's obligation under this warranty is limited to the repair of defects without charge by a Bloomfield Authorized Service Agency or one of its sub-agencies. This service will be provided on customer's premises for non-portable models. Portable models (a device with a cord and plug) must be taken or shipped to the closest Authorized Service Agency, transportation charges prepaid, for services.

In addition to restrictions contained in this warranty, specific limitations are shown below (Additional Warranty Exclusions). Bloomfield Industries Authorized Service Agencies are located in principal cities.

This warranty is valid in the United States and void elsewhere. Please consult your classified telephone directory or your food service equipment dealer; or, for information and other details concerning warranty, write to:

Service Parts Department  
Wells Bloomfield, LLC

10 Sunnen Drive, St. Louis, MO 63143

Phone: (314) 678-6336... Fax: (314) 781-2714

## SERVICE POLICY AND PROCEDURE GUIDE ADDITIONAL WARRANTY EXCLUSIONS

1. Resetting of safety thermostats, circuit breakers, overload protectors, or fuse replacements unless warranted conditions are the cause.
2. All problems due to operation at voltages other than specified on equipment nameplates; conversion to correct voltage must be the customer's responsibility.
3. All problems due to electrical connections not made in accordance with electrical code requirements and wiring diagrams supplied with the equipment.
4. Replacement of items subject to normal wear, to include such items as knobs and light bulbs. Normal maintenance functions including adjustment of thermostats, microswitches, and replacement of fuses and indicating lights are not covered under warranty.
5. All problems due to inadequate water supply, such as fluctuating, or high or low water pressure.
6. All problems due to mineral/calcium deposits, or contamination from chlorides/chlorines. De-liming is considered a preventative maintenance function and is not covered by warranty.
7. Full use, care and maintenance instructions are supplied with each machine. Those miscellaneous adjustments noted are customer responsibility. Proper attention will prolong the life of the machine.
8. Travel mileage is limited to sixty (60) miles from an authorized Service Agency or one of its sub-agencies.
9. All labor shall be performed during normal working hours. Overtime premium shall be charged to the customer.
10. All genuine Bloomfield replacement parts are warranted for ninety (90) days from date of purchase on non-warranted equipment. **Any use of non-genuine Bloomfield parts completely voids any warranty.**
11. Installation, labor and job check-out are not considered warranty.
12. Charges incurred by delays, waiting time or operating restrictions that hinder the service technicians ability to perform services are not covered by warranty. This includes institutional and correctional facilities.

## SHIPPING DAMAGE CLAIMS PROCEDURE

NOTE: For your protection, please note that equipment in this shipment was carefully inspected and packaged by skilled personnel before leaving the factory.

Upon acceptance of this shipment, the transportation company assumes full responsibility for its safe delivery.

### IF SHIPMENT ARRIVES DAMAGED:

1. **VISIBLE LOSS OR DAMAGE:** Be certain that any visible loss or damage is noted on the freight bill or express receipt, and that the note of loss or damage is signed by the delivery person.
2. **FILE CLAIM FOR DAMAGE IMMEDIATELY:** Regardless of the extent of the damage.

3. **CONCEALED LOSS OR DAMAGE:** if damage is unnoticed until the merchandise is unpacked, notify the transportation company or carrier immediately, and file "CONCEALED DAMAGE" claim with them. This must be done within fifteen (15) days from the date the delivery was made to you. Be sure to retain the container for inspection.

Wells Bloomfield cannot assume liability for damage or loss incurred in transit. We will, however, at your request, supply you with the necessary documents to support your claim.

## TABLE OF CONTENTS

WARRANTY STATEMENT	xi
SPECIFICATIONS	1
FEATURES & OPERATING CONTROLS	2
PRECAUTIONS & GENERAL INFORMATION	3
AGENCY LISTING INFORMATION	3
INSTALLATION INSTRUCTIONS	4
OPERATION	6
BREWING TEA	8
CLEANING INSTRUCTIONS	9
TROUBLESHOOTING SUGGESTIONS	10
SERVICING INSTRUCTIONS	11
Deliming Instructions	15
EXPLODED VIEW & PARTS LIST	16
WIRING DIAGRAMS	19

## INTRODUCTION

Thank You for purchasing this Wells Bloomfield appliance.

Proper installation, professional operation and consistent maintenance of this appliance will ensure that it gives you the very best performance and a long, economical service life.

This manual contains the information needed to properly install this appliance, and to use, care for and maintain or repair the appliance in a manner which will ensure its optimum performance.

## SPECIFICATIONS

8740: 3 - 5 Gallon Ice Tea Brewers					
MODEL	DIMENSIONS	VOLTS	WATTS	AMPS 1ø	POWER SUPPLY CORD
8740	34-1/4" high,	120V	1515	13	NEMA 5-15P
8740-35G	11-1/4" wide,	220-240V	1800	7.83	CEE 7/VII
8740-35GUK	19-27/32" deep	220-240V	1800	7.83	CW 3100

## APPLICABILITY

This manual applies to the following Wells Bloomfield product:  
8740 3 - 5 Gallon Tea Brewer

# FEATURES AND OPERATING CONTROLS

## 3-5 GAL. TEA BREWER MODEL 8740

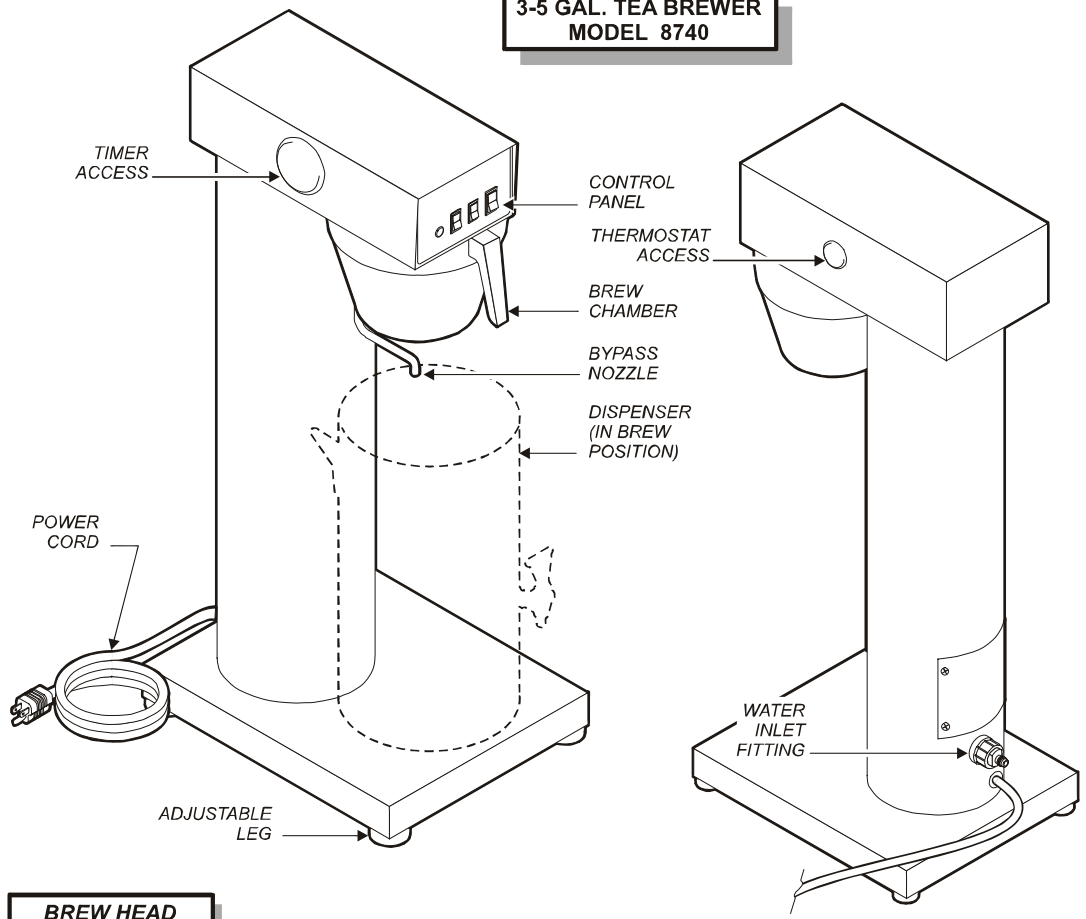

### BREW HEAD (BREW CHAMBER REMOVED)

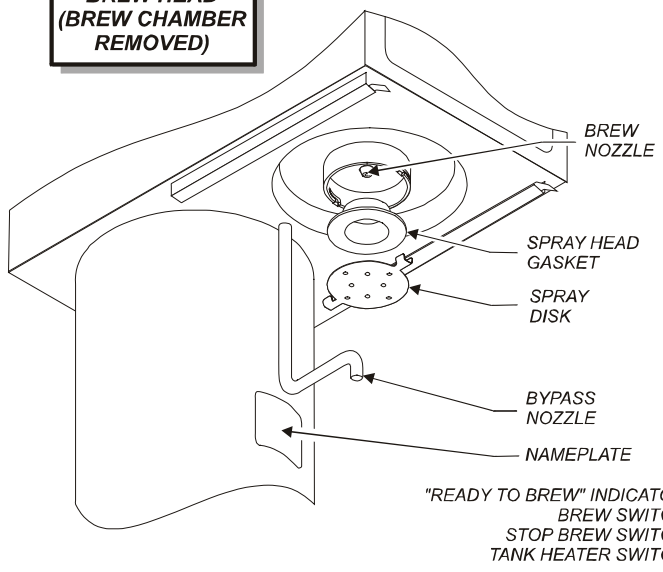

### CONTROL PANEL

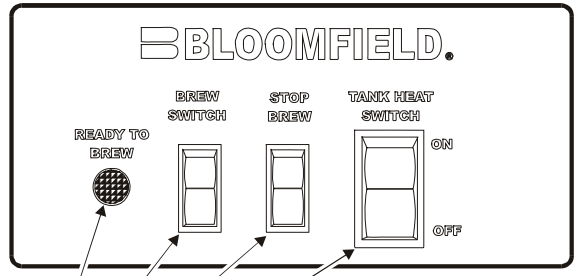

- "READY TO BREW" INDICATOR
- BREW SWITCH
- STOP BREW SWITCH
- TANK HEATER SWITCH

IL1684

Fig. 1 Model 8740 Features and Operating Controls

## PRECAUTIONS AND GENERAL INFORMATION



### WARNING: ELECTRIC SHOCK HAZARD

All servicing requiring access to non-insulated components must be performed by qualified service personnel. Do not open any access panels which require the use of tools. Failure to heed this warning can result in electrical shock.



### WARNING: INJURY HAZARD

All installation procedures must be performed by qualified personnel with full knowledge of all applicable electrical and plumbing codes. Failure could result in property damage and personal injury.



### WARNING: ELECTRIC SHOCK HAZARD

Brewer must be properly grounded to prevent possible shock hazard. DO NOT assume a plumbing line will provide such a ground. Electrical shock will cause death or serious Injury.



### WARNING: BURN HAZARD

This appliance dispenses very hot liquid. Serious bodily injury from scalding can occur from contact with dispensed liquids.

This appliance is intended for commercial use only.

This appliance is intended for use to brew beverage products for human consumption. No other use is recommended or authorized by the manufacturer or its agents.

This appliance is intended for use in commercial establishments, where all operators are familiar with the appliance use, limitations and associated hazards. Operating instructions and warnings must be read and understood by all operators and users.

Except as noted, this piece of equipment is made in the USA and has American sizes on hardware. All metric conversions are approximate and can vary in size.

The following trouble shooting, component views and parts lists are included for general reference, and are intended for use by qualified service personnel.

This manual should be considered a permanent part of this appliance. The manual must remain with the appliance if it is sold or moved to another location.



### CAUTION: EQUIPMENT DAMAGE

DO NOT plug in or energize this appliance until all *Installation Instructions* are read and followed. Damage to the Brewer will occur if these instructions are not followed.



### CAUTION: BURN HAZARD

Exposed surfaces of the appliance, brew chamber and dispenser may be HOT to the touch, and can cause serious burns.

## AGENCY LISTING INFORMATION

This brewer is  listed under UL file E9253.

This brewer meets  Standard 4 only when installed, operated and maintained in accordance with the enclosed instructions.



E9253



E9253



STD 4

## INSTALLATION

### READ THIS CAREFULLY BEFORE STARTING THE INSTALLATION

#### IMPORTANT:

To enable the installer to make a quality installation and to minimize installation time, the following suggestions and tests should be done before the actual unit installation is started:



#### CAUTION: EQUIPMENT DAMAGE

DO NOT plug in or energize this appliance until all Installation Instructions are read and followed. Damage to the Brewer will occur if these instructions are not followed.



#### CAUTION: UNSTABLE EQUIPMENT HAZARD

It is very important for safety and for proper operation that the brewer is level and stable when standing in its final operating position.

**NOTE:** Water supply inlet line must meet certain minimum criteria to insure successful operation of the brewer. Bloomfield recommends 1/4" copper tubing for installation of less than 12 feet and 3/8" for more than 12 feet from a 1/2" water supply line.

**NOTE:** This equipment must be installed to comply with applicable federal, state and local plumbing codes and ordinances.

Unpack the unit. Inspect all components for completeness and condition. Ensure that all packing materials have been removed from the unit.

Verify that the Spray Head Gasket and Spray Disk are properly installed.

#### PLUMBER'S INSTALLATION INSTRUCTIONS

Brewer must be connected to a **POTABLE WATER, COLD WATER** line. Flush water line before connecting to Brewer.

DO NOT use a saddle valve with a self-piercing tap for the water line connection. Such a tap can become restricted by waterline debris. For systems that must use a saddle tap, shut off the main water supply and drill a 3/16" (minimum) tap for the saddle connection, in order to insure an ample water supply. Remember to flush the line prior to installing the saddle.

The brewer must be installed on a water line with average pressure between 20 PSI and 90 PSI. If your water pressure exceeds 90 PSI at anytime, a pressure regulator must be installed in the water supply line to limit the pressure to not more than 90 PSI in order to avoid damage to lines and solenoid.

A water shut-off valve should be installed on the incoming water line in a convenient location (Use a low restriction type valve, such as a 1/4-turn ball valve, to avoid loss of water flow thru the valve).

NSF requires that the brewer be able to be moved for cleaning underneath. A flex line or loops of copper tubing will satisfy this requirement. See Figure 2 below.

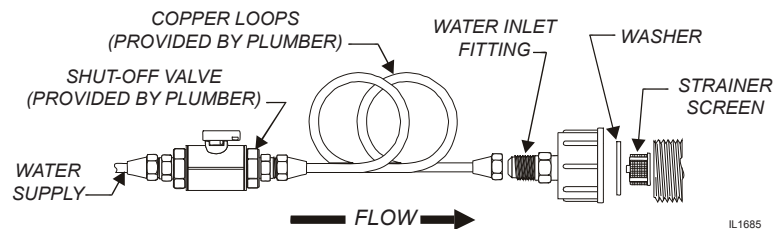

Fig. 2 Water Supply Installation

## INSTALLATION (continued)

### ELECTRICIAN'S INSTALLATION INSTRUCTIONS

REFER TO ELECTRICAL SPECIFICATIONS - Page 1  
Check the nameplate to determine correct electrical service required for the Brewer to be installed.

**IMPORTANT:** Before connecting to electricity, make sure automatic brewers are connected to the water supply.

**Model 8740** is equipped with a cord and plug.  
It requires a 115 - 125 volt 20 amp circuit (50/60 Hz, 2 wire plus ground, with NEMA 5-15R receptacle).

### PREPARATION

The water tank must be filled prior to operation. Slide an empty brew chamber in place under the brew head. Place an empty dispenser under the brew chamber.

Be sure the unit is connected to the water supply, the water supply is turned **ON** and the "TANK HEATER SWITCH" is **OFF**. Connect the unit to electric power.

Press the "START BREW" switch to initiate a brew cycle. The solenoid will open and begin filling the tank. Initiate consecutive brew cycles until water begins to flow from the brew head.

When all water stops dripping, discard all water generated. Press the "TANK HEATER SWITCH" to **ON**. The heating elements will begin heating the water in the tank. When the "READY TO BREW" light glows the unit is ready for use.



### WARNING SHOCK HAZARD

Brewer must be properly grounded to prevent possible shock hazard. **DO NOT** assume a plumbing line will provide such a ground. Electrical shock will cause death or serious injury.

### IMPORTANT:

Supply power must match nameplate for voltage and phase. Connecting to the wrong voltage will damage the brewer or result in decreased performance. Such damage is not covered by warranty.

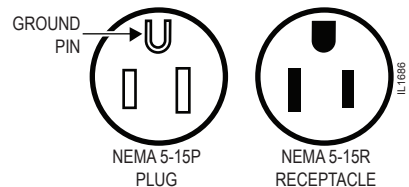

Fig. 3 Plug Configuration

**IMPORTANT:** The ground prong of the plug is part of a system designed to protect you from electrical shock in the event of internal damage. Never cut off the ground prong nor twist a blade to fit an existing receptacle. Contact a licensed electrician to install the proper circuit and receptacle.

**IMPORTANT:** Do not connect brewer to electrical power until you are ready to fill the tank. See instructions at left.



## OPERATION

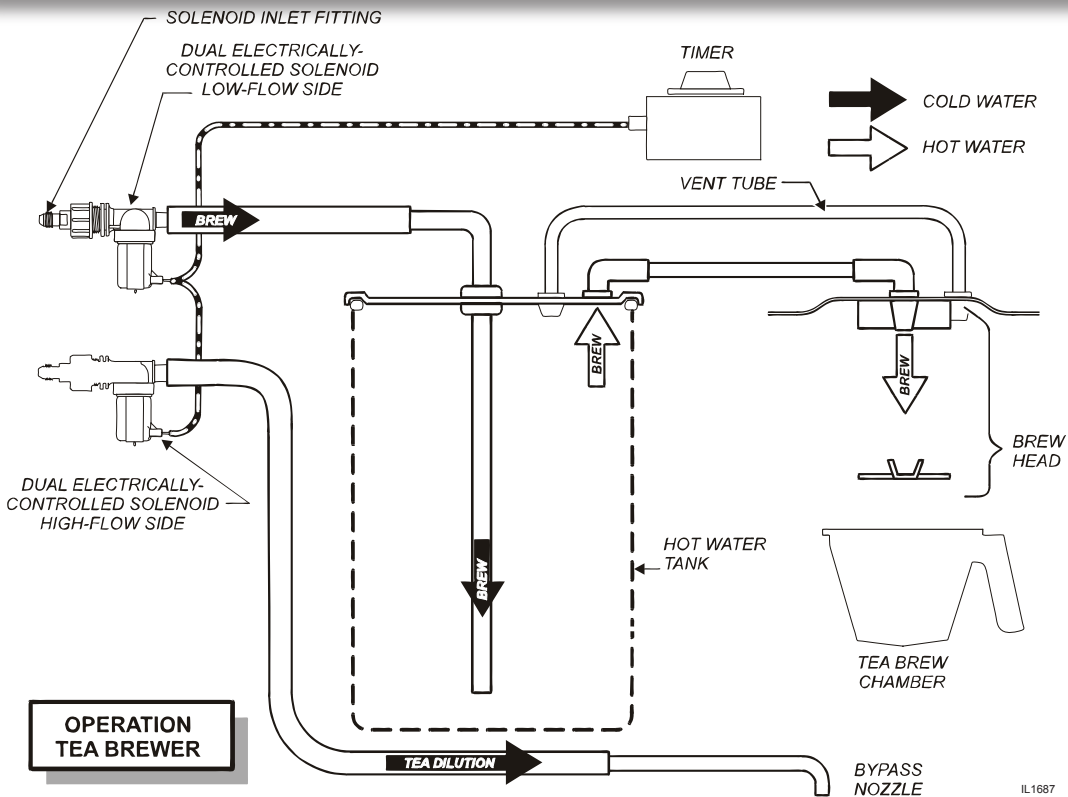

Fig. 4 Brewer Operation Diagram

### IMPORTANT:

Tank must be full of water before pressing TANK HEATER SWITCH "ON". Heating elements will be damaged if allowed to operate without being fully submerged in water. Damage caused by operating the brewer without water in the tank is **NOT COVERED BY WARRANTY**.

### A. START-UP

For initial start-up, or if the brewer has not been used for an extended period of time:

- Be sure spray disk and brew gasket are properly installed in the brew head.
- Be sure the water supply is properly connected and the water supply valve is turned ON.
- Be sure the WATER TANK IS FILLED.

**IMPORTANT:** Fill the water tank before energizing this unit:

1. Insert the brew chamber (empty) and place an empty dispenser in place under the brew chamber.
2. Be sure the TANK HEATER SWITCH is "OFF". Plug the unit into an appropriate receptacle.
3. Press The BREW switch. Water will start filling the tank. Run several consecutive brew cycles until water flows from the brew chamber.
4. When water stops dripping from the brew chamber, empty the dispenser, then press TANK HEAT switch "ON". The heating element will begin heating water in the tank. When the water has reached the proper brewing temperature, the "READY TO BREW" light will glow.



## OPERATION (continued)

### WATER HEATER

Water temperature is sensed by a thermobulb inserted into the water tank. This temperature signal is fed to the mechanical thermostat.

The temperature setpoint is adjustable. Heating element is energized by the thermostat.

Excessive temperature will trip the hi-limit safety switch. The hi-limit will automatically reset when the brewer cools.

### WATER FLOW

#### AUTOMATIC OPERATION

Pressing the BREW switch starts the timer, which in turn energizes the solenoid valves. This allows water from an external water supply to flow into the water tank. The incoming water forces heated water out of the tank to perform the brew. Additionally, a measured amount of unheated water is bypassed into the dispenser to dilute and cool the brew.

The solenoid uses a flow control device so that flow is consistent between 20 p.s.i. and 90 p.s.i.

The length of time the solenoid is open is controlled by the timer setting.

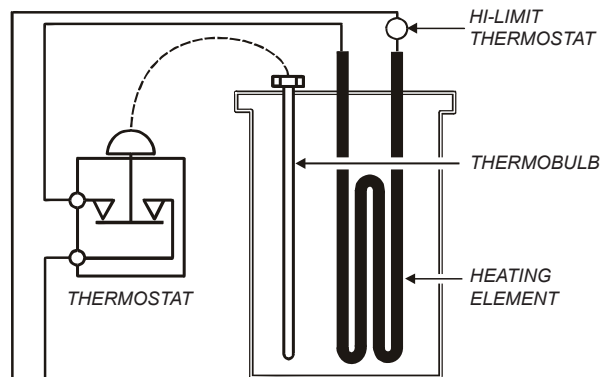

Fig. 5 Heat Control Diagram

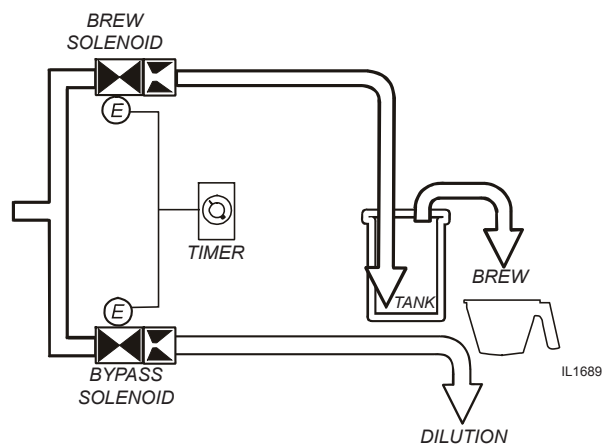

Fig. 6 Water Flow Diagram

## BREWING TEA



### CAUTION: BURN HAZARD

Exposed surfaces of the brewer, brew chamber and dispenser may be HOT to the touch, and can cause serious burns.



### CAUTION: BURN HAZARD

To avoid splashing or overflowing hot liquids, ALWAYS place an empty dispenser under the brew chamber before starting the brew cycle. Failure to comply can cause serious burns.



### CAUTION: BURN HAZARD

After a brew cycle, brew chamber contents are HOT. Remove the brew chamber and dispose of used tea leaves with care. Failure to comply can cause serious burns.

### A. PREPARATION

Place one (1) genuine Bloomfield paper filter into the brew chamber.

Add an amount of fresh tea leaves to the brew chamber appropriate to the brew volume.

NOTE: the brewer can brew any volume between 3 and 5 gallons, and is factory set for a 3 gallons brew volume. If other brew volumes are desired, refer to SOLENOID TIME ADJUSTMENT, page 13.

Gently shake the brew chamber to level the bed of tea leaves.  
Slide the brew chamber into place under the brew head.

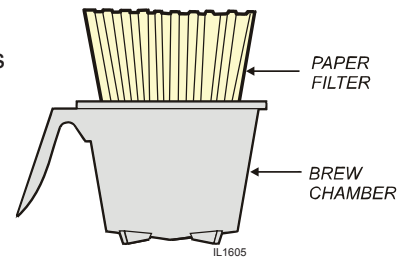

Fig. 7 Tea Brew Chamber

### B. AUTOMATIC OPERATION

BE sure "READY TO BREW" light is lit.

Place the appropriate *EMPTY* dispenser in place under the brew chamber. If a brew-thru lid is used, be sure the bypass opening in the lid is directly under the bypass nozzle.

Press the "BREW" switch. The brew solenoid will open for an amount of time determined by the timer setting, admitting a measured quantity of water into the tank.

Inlet water will displace a like amount of heated water from the tank. The hot water will be forced into the brew head where it will spray over the bed of grounds. Freshly brewed tea will begin to fill the dispenser. Additionally, a measured amount of cold dilution water will flow from the bypass nozzle into the dispenser.

When the flow and all dripping stops at the end of the brew cycle, the tea is ready to serve.

Discard the contents of the brew chamber and rinse it in a sink. When the "READY TO BREW" light glows, the brewer is ready for another brew cycle.

## CLEANING INSTRUCTIONS

### PROCEDURE: Clean Tea Brewer

**PRECAUTIONS:** Disconnect brewer from electric power.  
Allow brewer to cool.

**FREQUENCY:** Daily

**TOOLS:** Mild Detergent, Clean Soft Cloth or Sponge  
Bristle Brush, Bottle Brush

1. Disconnect brewer from electric power.  
Allow brewer to cool before cleaning.
2. Remove dispenser.
3. Remove and empty brew chamber.
4. Remove the spray disk from the brew head (See figure 8):  
Press up on the spray disk ears, then turn the disk to the left to unlatch. Remove the gasket from inside the brew head.
5. Wipe inside of brew head and area around the brew head with a soft clean cloth or sponge moistened with clean water.
6. Wash the spray disk in a sink using warm water and a mild detergent. A bristle brush may be used to clear clogged spray holes. Rinse the spray disk with clean water and allow to air dry.
7. Wash the brew chamber in a sink using warm water and a mild detergent. Rinse with clean water and allow to air dry.
8. Wipe the exterior of the brewer with a soft clean cloth or sponge moistened with clean water.
9. Reinstall the gasket **INSIDE** the brew head, and then reinstall the spray disk.
10. Clean dispensers by filling with warm soapy water. Empty and rinse with clean water. Wipe the exterior with a soft clean cloth or sponge moistened with clean water. Invert and allow to air dry.

Procedure is complete



### CAUTION: BURN HAZARD

Brewing and serving temperatures of tea are extremely hot.  
Hot tea will cause serious skin burns.



### CAUTION: SHOCK HAZARD

Do not submerge or immerse brewer in water.

### IMPORTANT:

DO NOT use steel wool, sharp objects, or caustic, abrasive or chlorinated cleansers to clean the brewer or dispensers.

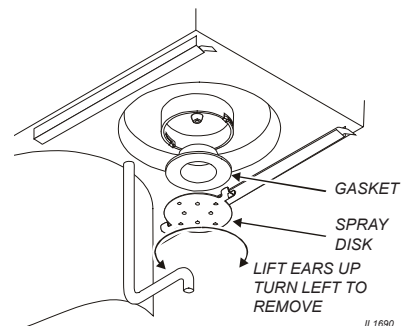

Fig. 8 Cleaning

## TROUBLESHOOTING SUGGESTIONS

SYMPTOM	POSSIBLE CAUSE	SUGGESTED REMEDY
Water won't heat	Brewer unplugged or circuit breaker tripped	Check power supply cord Check / reset circuit breaker
	Tank heater switch OFF	Press switch to ON
	Temperature setpoint too low	Set for desired temperature
	Hi-Limit safety switch tripped	Allow to cool hi-limit will self-reset
	Damaged internal component or wiring	Examine wiring & connectors, controller, power board and heating element, Repair/replace as needed
Tea level too high or low	Timer out of adjustment	Adjust timer
Brew chamber overflows	Too many filter papers or wrong filter paper	Use one (1) genuine Bloomfield filter per brew
	Brew chamber dispense hole plugged	Thoroughly clean brew chamber
	Too much tea leaves	Use correct amount of tea
Sprays water from brew head	Spray gasket improperly installed	Check/reinstall gasket on INSIDE of brew head
No brew	Spray disk plugged	Clean spray disk
	Damaged internal component or wiring	Check switches, timer and solenoid. Repair, replace as needed
	Water supply OFF	Turn water supply ON
	Solenoid inlet strainer plugged	Clean strainer
	Water filter (if used) plugged	Replace filter element
Poor coffee quality	Keep brewer and dispenser clean. Install a taste and odor filter in water supply, and replace cartridges regularly. Use a quality fresh supply of tea leaves. Use amount of tea leaves appropriate to brew volume.	

## SERVICING INSTRUCTIONS

### ACCESS PLUGS

Use a small flat-blade screwdriver or similar implement to pry the hole plug from the access hole in the top wrap.

### HOT WATER TEMPERATURE:

Remove right 7/8" hole plug to access temperature control.

### WATER DELIVERED VOLUME:

Remove left 2" hole plug to access water volume timer.

### ACCESS PANELS

#### TOP WRAP:

Remove top wrap to access hot water tank, thermostat, timer, switches and brew circuit tubing.

Top wrap is held by two screws at the front and two screws at the rear.

#### REAR PANEL:

Remove rear panel to access wiring and brew solenoid.

Rear panel is held by two screws and a retaining lip.



### CAUTION: SHOCK HAZARD

Opening access panels on this brew may expose uninsulated electrical components. Disconnect brewer from electrical power before removing any panel.

#### NOTE ;

Time and temperature controls may be accessed without removing cabinet panels by removing the appropriate hole plug from the top wrap.

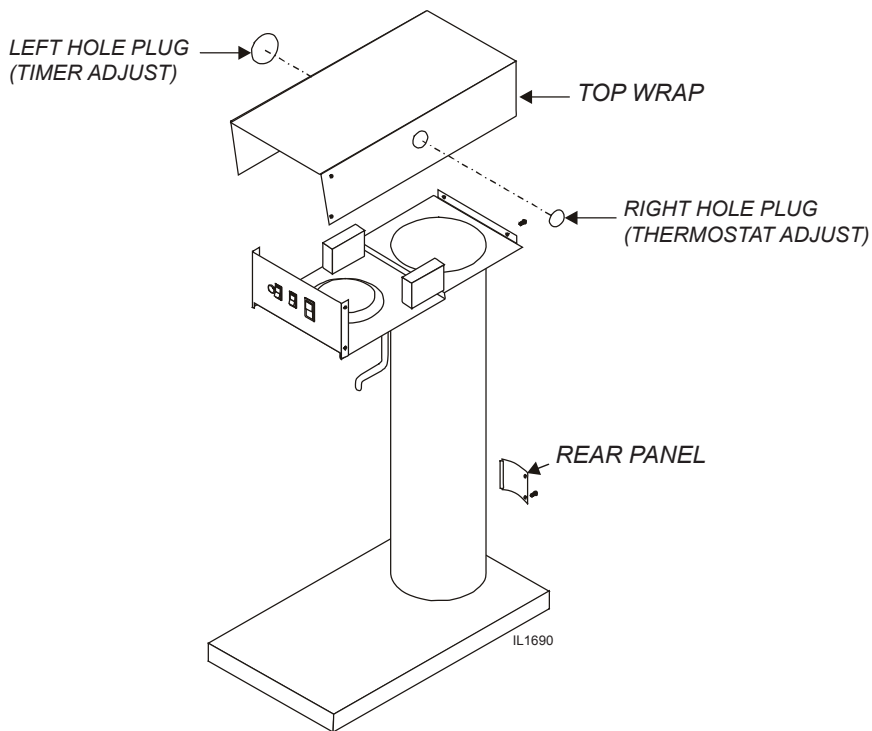

Fig. 8 Access Panels

## SERVICING INSTRUCTIONS (continued)



### CAUTION: SHOCK HAZARD

Live electrical circuits are exposed during this procedure. Use care to avoid uninsulated electrical connectors.

**NOTE:** Optimum brewing temperature is 195°F to 205°F (90°C to 96°C). Thermostat should be adjusted to a maximum temperature of 200°F (95°C).

### IMPORTANT:

A mechanical thermostat will maintain temperature within  $\pm 5^\circ\text{F}$ .

To prevent boiling water in the brewer, controller should be adjusted to a maximum temperature equal to the local boiling temperature minus 5°F, or 205°F (97°C), whichever is less.

**NOTE:** 1/8 turn = approximately 10°F (5.6°C).

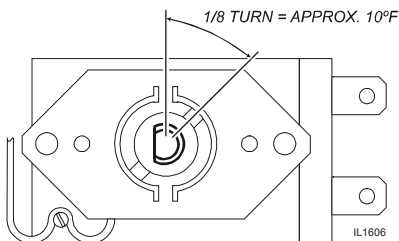

Fig. 10 Adjust Thermostat

### TEMPERATURE ADJUSTMENT

Energize brewer and allow unit to heat. When the READY TO BREW light first glows, read the temperature.

Thermostat may be adjusted by removing the right button plug. Carefully check the water temperature at the outlet of the brew chamber. The temperature at this location is approximately 5° F less than the actual brew temperature.

Adjust thermostat by turning shaft; clockwise increases temperature. 1/8 turn = approximately 10°F, or 5.6°C. Refer to Table 1 below for proper brewing temperature based on altitude.

Upon completion, remove thermometer and reinstall the vent line and top wrap.

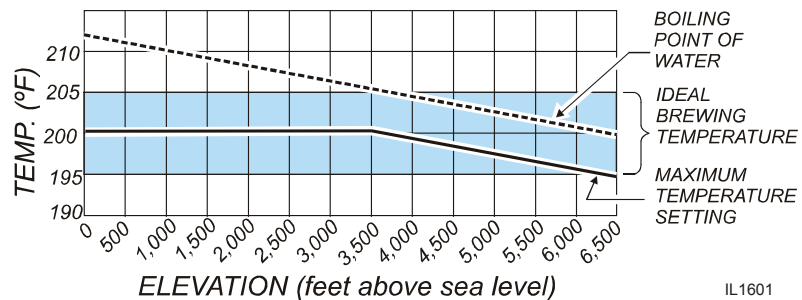

IL1601

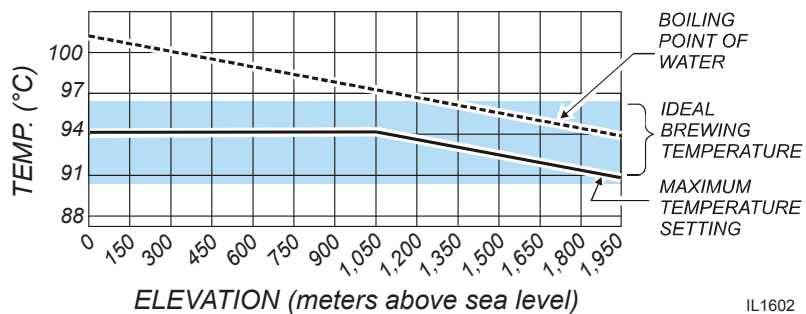

IL1602

Table 1 Boiling Temperature by Altitude

## SERVICING INSTRUCTIONS (continued)

### SOLENOID TIMER ADJUSTMENT

The amount of water dispensed automatically during a brew cycle is controlled by the SOLENOID TIMER.

Place empty dispenser under brew chamber. Press the BREW switch. Measure total amount of water delivered. To adjust amount:

Remove left button plug. Adjust timer; clockwise increases time. Run several cycles to check amount of water delivered. Reinstall button plug.

### REMOVE TANK LID ASSEMBLY

Unplug brewer or turn circuit breaker *OFF*. Turn *OFF* water supply. Remove top wrap.

Disconnect brew fill and outlet tubes from tank lid fittings.

Disconnect all wiring from thermostat, hi-limit and heating element.

Loosen the two nuts at the ends of the tank hold-down bracket. Remove hold-down bracket by sliding short slotted end off of locking stud and lifting it off. Remove cover assembly by lifting it straight up.

Reassemble in reverse order.

### REPLACE THERMOSTAT

Unplug brewer or turn circuit breaker *OFF*. Turn *OFF* water supply. Remove top panel.

Disconnect all wiring from thermostat only. Loosen and free jam nut from pass-thru fitting securing temperature sensing bulb. Remove two screws holding thermostat to bracket.

Lift out thermostat, sensing bulb and thermostat gasket.

Reassemble in reverse order.

### REPLACE HEATING ELEMENT

Remove tank lid assembly per above.

Remove two hex nuts holding element to cover. Pull element from mounting holes.

Reassemble in reverse order.

**IMPORTANT:** Water pressure must be between 20 p.s.i and 90 p.s.i. flowing pressure. If water pressure exceeds this value, or if water pressure varies greatly, a pressure regulator must be installed in the water supply line.

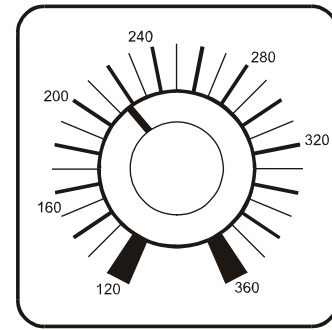

IL1679

Fig. 11 Adjust Solenoid Timer

**IMPORTANT:** Before setting assembly into tank, make sure tank lid gasket is properly seated on flange of lid.

**IMPORTANT:** When mounting thermostat, be sure a new seal washer is placed below the fitting on the capillary line. Push sensing bulb thru tank lid until fitting seats.

If replacing gray-bodied thermo with p/n 8512-51, be sure to remove tube from thermowell.

Tighten capillary lock nut only enough to ensure no water leakage. Excessive tightening is not necessary.

**IMPORTANT:** When replacing heating element, also replace seal gaskets.



## SERVICING INSTRUCTIONS (continued)

### REPLACE SOLENOID

Symptom: Automatic brewer will not flow water; or, automatic brewer drips continuously from brew head.

Unplug power cord or turn circuit breaker *OFF*. Turn *OFF* and disconnect water supply from brewer inlet fitting. Remove rear access panel.

Unscrew water inlet piping from solenoid.

Remove solenoid from brewer.

Note position of brew water and bypass water tubes on solenoid  
Remove tubes from solenoid.

Disconnect wiring from solenoid.

Reassemble in reverse order.

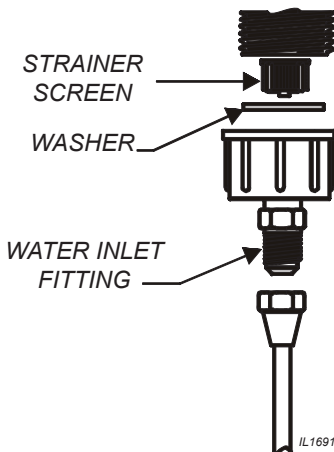

Fig. 12 Clean Strainer Screen

### CLEAN SOLENOID SCREEN

Symptom: Automatic brewer will not flow water.

Unplug power cord or turn circuit breaker *OFF*. Turn *OFF* and disconnect water supply from brewer inlet fitting.

Unscrew water inlet fitting from solenoid.

Using needle-nose pliers, withdraw strainer screen from solenoid. Clean screen under faucet. A stiff bristle brush may be used if necessary.

Reinsert screen in solenoid. Be careful to maintain correct orientation. (The *OPEN END* of the screen goes in *FIRST*.)

Reassemble in reverse order.

### REPLACE TIMER ASSEMBLY

Unplug power cord or turn circuit breaker *OFF*.

Remove top wrap. Remove knob and three screws holding timer to bracket. Disconnect wiring to timer.

Reassemble in reverse order.

Adjust timer as described on page 13

## SERVICING INSTRUCTIONS (continued)

### PROCEDURE: Delime the Water Tank

**PRECAUTIONS:** Disconnect brewer from electric power.  
Allow brewer to cool.

**FREQUENCY:** As required (Brewer slow to heat)

**TOOLS:** Deliming Solution  
Protective Gloves, Goggles & Apron  
Mild Detergent, Clean Soft Cloth or Sponge  
Bristle Brush, Bottle Brush  
Large Sink (or other appropriate work area)



### CAUTION: CHEMICAL BURN HAZARD

Deliming chemicals are caustic. Wear appropriate protective gloves and goggles during this procedure.

Never siphon deliming chemicals or solutions by mouth.

This operation should only be performed by qualified and experienced service personnel.

1. Unplug power cord. Turn off the water shut-off valve and disconnect the water supply line from the brewer inlet fitting.
2. Remove the tank lid assembly as described on page 13.
3. Remove the water tank from the brewer body by lifting straight up. Empty all water from the tank. Set the tank back into the brewer.
4. Mix 2 quarts of deliming solution according to the manufacturer's directions. Carefully pour the deliming solution into the water tank. Lower the lid assembly back onto the tank. Allow to sit for 30 minutes, or as directed by the manufacturer.
5. At end of soaking period, remove lid assembly from tank. Thoroughly rinse internal components of lid assembly with clear water. Using a stiff bristle brush, scrub the heating element and faucet water coil to remove lime and calcium build-up. Rinse with clean water. Store lid assembly in a safe location.
6. Remove the tank from the brewer and empty. Using a stiff bristle brush, scrub the interior of the water tank to remove lime and calcium build-up. Rinse with clean water.
7. Set the tank back into the brewer. Reassemble the tank lid to the water tank. Make sure the gasket is properly in place, and then reinstall lid clamps.
8. Reinstall wiring to heating element and thermostat.  
Reassemble piping for the faucet. Verify that all internal components are dry, then reinstall the top panel.
9. Reconnect brewer to electrical supply and reconnect water supply.
10. Install the brew chamber without filter paper or grounds. Run at least three full brew cycles and discard all water generated.
11. Brewer is ready to use.

**IMPORTANT:** DO NOT spill, splash or pour water or deliming solution into or over any internal component other than the inside of the water tank.

**IMPORTANT:** DO NOT allow any internal components to come into contact with the deliming solution. Take care to keep all internal components dry.

**NOTE:** Repeat steps 4 thru 5 as required to remove all scale and lime build-up.

**NOTE:** Normally, silicone hoses do not need to be delimed. Should deliming hoses become necessary, Bloomfield recommends replacing the hoses.

# EXPLODED VIEW: 8740 TEA BREWER

Model 8740

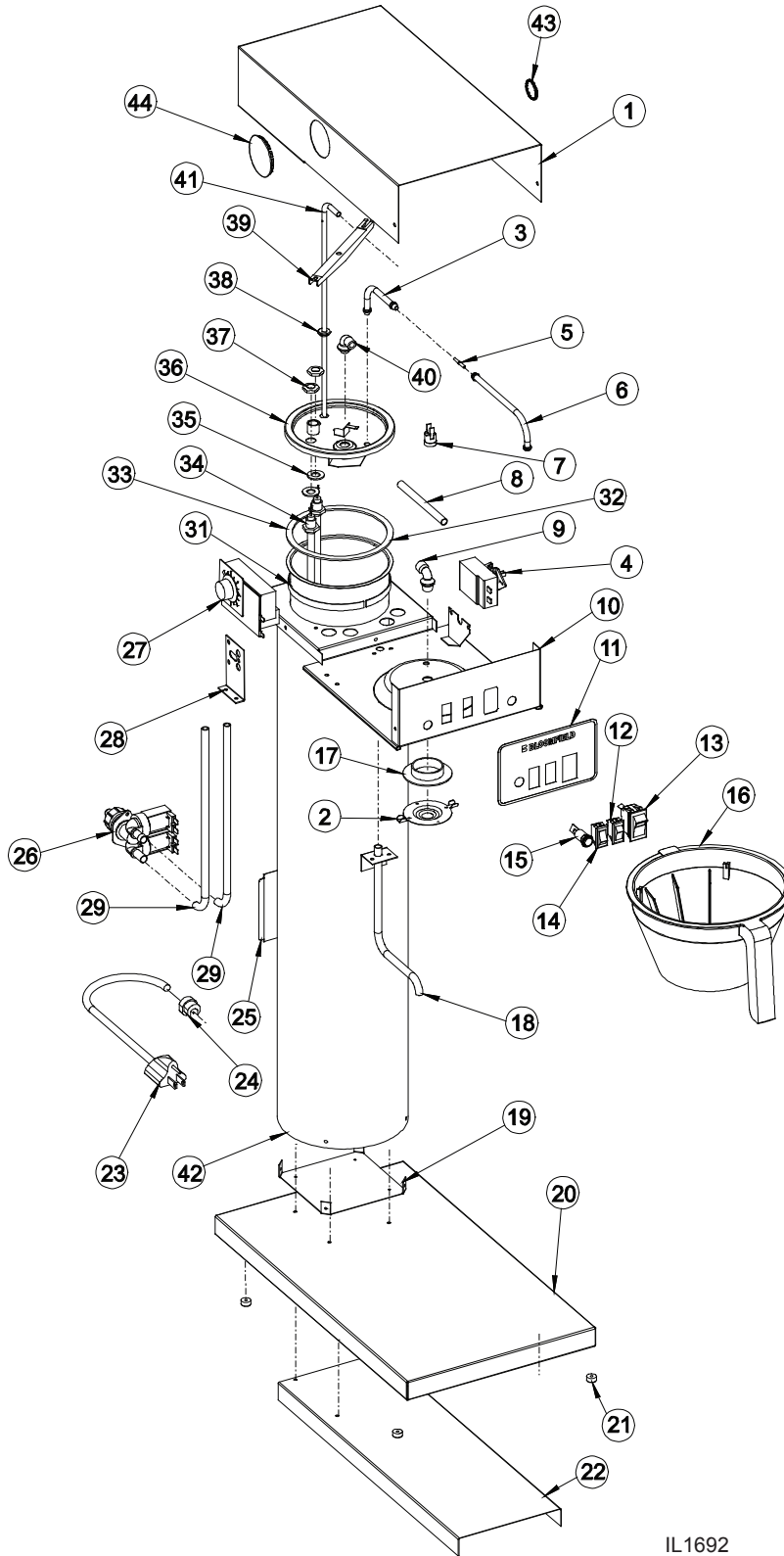

IL1692

## PARTS LIST: 8740 TEA BREWER

ITEM	PART #	DESCRIPTION	APPLICATION
1		WRAP, TOP COVER	
2	F4-72186	SPRAY DISK	
3	2V-70102	VENT, TUBE SHORT	
4	WS-8512-51	THERMOSTAT	
5	2K-72241	CONNECTOR	
6	2V-70398	VENT, TUBE LONG	
7	2T-47499	THERMO, HI-LIMIT	
8	2V-76439	TUBE, SPRAYHEAD	
9	2K-70130	ELBOW, SPRAYER	
10		PLATE, BASIN	
11	2M-76441	LABEL, BASIN	
12	2E-71259	SWITCH, STOP BREW	
13	2E-72214	SWITCH, TANK HEATER	
14	2E-70733	SWITCH, START BREW	
15	2J-70644	LIGHT PILOT GREEN 250V	230K, 230V
15	2J-72671	LIGHT, PILOT GREEN	
16	2D-73101	BREW CHAMBER	
17	2I-72215	GASKET, SPRAYHEAD	
18		SPOUT, BYPASS	
19		PLATE, BODY MOUNTING	
20		BASE	
21		STANDOFF	
22		SUPPORT, BASE	
23	2E-70353	CORD ASSY, 120V	120V
23	2E-72921	CORD & CAP ASSY UK (CE)	230K
23	F4-WL0143	CORD & EU PLUG MALE TERM	230V
24	2K-70215	STRAIN RELIEF	
24	2K-70648	STRAIN RELIEF SMALL	230K, 230V
25	F4-76479	DOOR, ACCESS SOLENOID	
26	2E-73282	SOLENOID DUAL 120V .60V/.19 GPM	
26	2E-Z14023	SOLENOID DUAL .6/.19 240V	230K, 230V
27	2P-70431	TIMER, 8 MIN	
27	2P-72478	TIMER 8-MIN 240V	230K
28		BRACKET, TIMER	
29		TUBE, .313 x 33" SILICONE	
31		SPACER, TANK	
32	2D-70110	TANK BODY	
33	2I-70147	GASKET, TANK	
34	2N-70143UL	ELEMENT, 120V 1500W	
34	2N-70173UL	ELEMENT, 240V 1800W TANK	230K, 230V
35	2I-70152	GASKET, HEAT ELEMENT	
36		LID, TANK	
37	2C-70175	NUT, HEAT ELEMENT	
38	2I-72390	GROMMET	
39	2C-70134	STRAP, TANK HOLD-DOWN	
40	2K-70103	ELBOW, OUTLET	
41	2V-73034	TUBE, FILL 90° BEND	
42		LOWER HOUSING	
43	2P-70714	BUTTON PLUG 7/8"	
44	2P-70053	BUTTON PLUG, 2"	
	2P-73318	PLUG, LID .510 (not shown)	
	2P-73320	PLUG, LID .687 (not shown)	

## SERVICE KITS

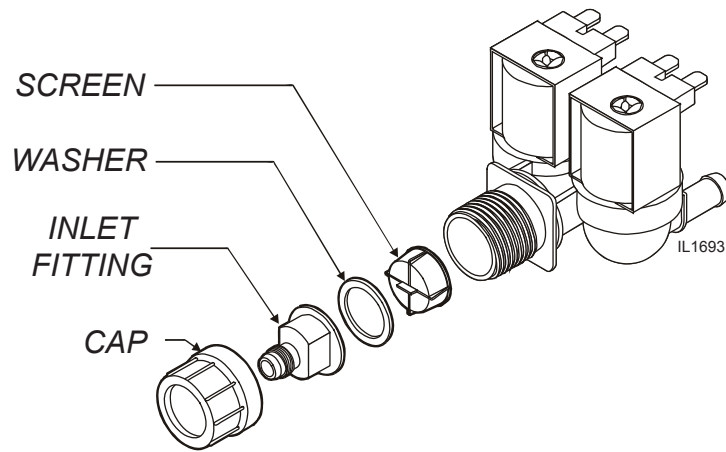

### SERVICE KITS

#### SOLENOID REPAIR KITS

- 2E-73282 Solenoid, Complete, Dual
- WS-85218 Inlet Fitting Kit (includes cap, inlet fitting, washer and screen)
- WS-85219 Inlet Strainer

# WIRING DIAGRAM

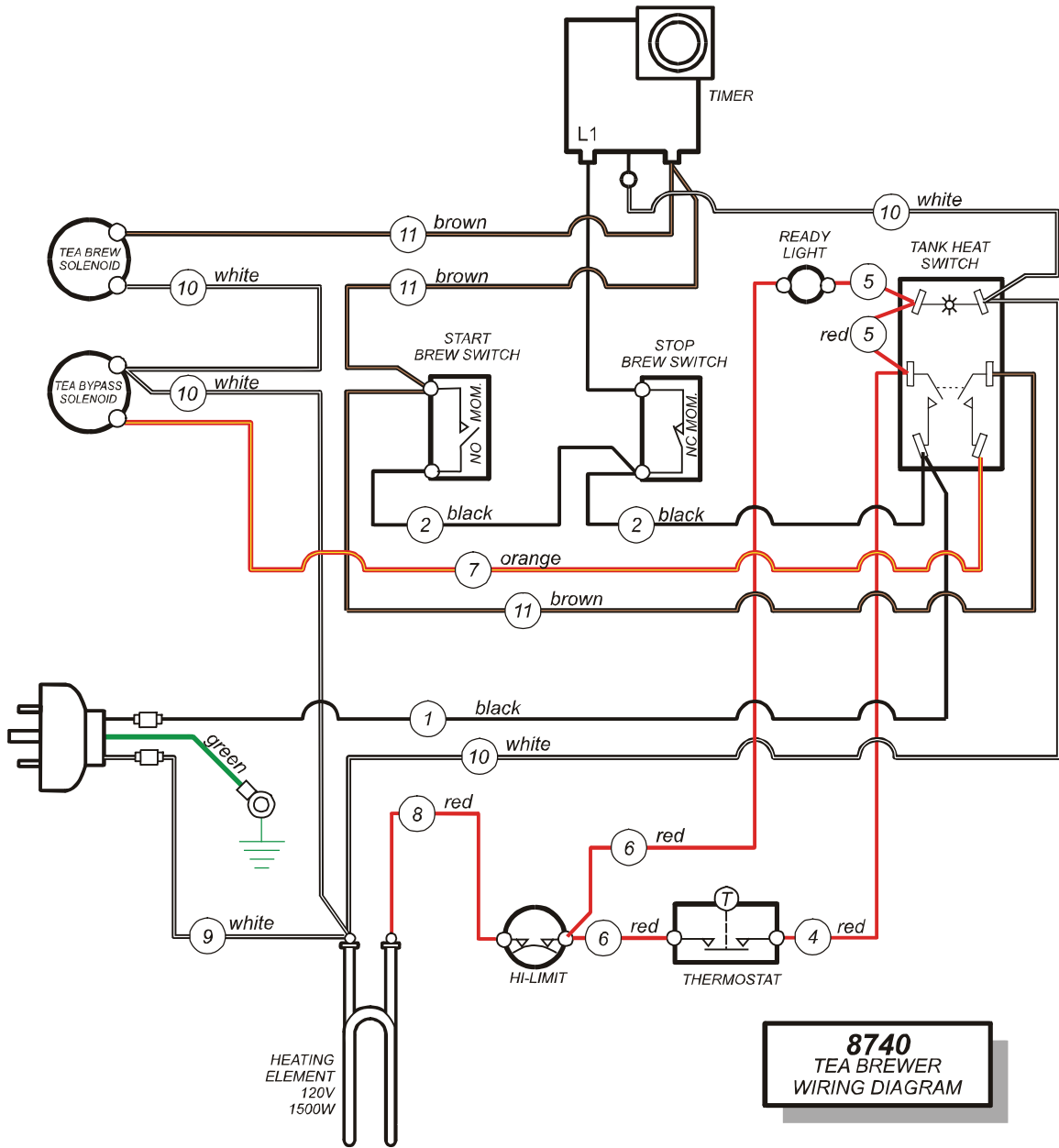

**8740**  
TEA BREWER  
WIRING DIAGRAM

## NOTES



## NOTES

**CFESA**

Commercial Food Equipment Service Association

Wells Bloomfield proudly supports CFESA  
Commercial Food Equipment Service Association

**SERVICE TRAINING - QUALITY SERVICE**



**CUSTOMER SATISFACTION**

**WELLS BLOOMFIELD**

**WELLS BLOOMFIELD, LLC**

10 Sunnen Drive, St. Louis, MO 63143  
telephone: 314-678-6336 fax: 314-781-2714  
[www.wellsbloomfield.com](http://www.wellsbloomfield.com)