

BLOOMFIELD INDUSTRIES
10 Sunnen Drive
St. Louis, MO 63143
telephone: 314-678-6336
fax: 314-781-2714
www.wellsbloomfield.com



Model 1222 Dispenser

**OWNERS MANUAL
for**

**HOT WATER
DISPENSER**

**2 GALLON MODELS:
1222
1222CA**

**5 GALLON MODELS:
1225
1226**

Includes:

**Installation
Operation
Use & Care
Servicing Instructions**

WARRANTY STATEMENT

All electrical equipment manufactured by WELLS BLOOMFIELD, LLC is warranted against defects in materials and workmanship for a period of one year from the date of original installation or eighteen (18) months from the date of shipment from our factory, whichever comes first, and is for the benefit of the original purchaser, except that:

- a. airpots carry a 30 day parts warranty only.
- b. dispensers; i.e., tea and coffee carry a 90 days parts warranty only, excludes decanters.

THE FOREGOING OBLIGATION IS EXPRESSLY GIVEN IN LIEU OF ANY OTHER WARRANTIES, EXPRESSED OR IMPLIED, INCLUDING ANY IMPLIED WARRANTY OF MERCHANTABILITY OR FITNESS FOR A PARTICULAR PURPOSE, WHICH ARE HEREBY EXCLUDED.

WELLS BLOOMFIELD, LLC SHALL NOT BE LIABLE FOR INDIRECT, INCIDENTAL OR CONSEQUENTIAL DAMAGES OR LOSSES FROM ANY CAUSE WHATSOEVER.

This warranty is void if it is determined that upon inspection by an Authorized Service Agency that the equipment has been modified, misused, misapplied, improperly installed, or damaged in transit or by fire, flood or act of God.

It also does not apply if the serial nameplate has been removed or unauthorized service personnel perform service. The prices charged by Bloomfield Industries for its products are based upon the limitations in this warranty. Seller's obligation under this warranty is limited to the repair of defects without charge by a Bloomfield Authorized Service Agency or one of its sub-agencies. This service will be provided on customer's premises for non-portable models. Portable models (a device with a cord and plug) must be taken or shipped to the closest Authorized Service Agency, transportation charges prepaid, for services.

In addition to restrictions contained in this warranty, specific limitations are shown below (Additional Warranty Exclusions). Bloomfield Industries Authorized Service Agencies are located in principal cities.

This warranty is valid in the United States and void elsewhere. Please consult your classified telephone directory or your food service equipment dealer; or, for information and other details concerning warranty, write to:

Service Parts Department
Wells Bloomfield, LLC
10 Sunnen Drive, St. Louis, MO 63143
Phone: (314) 678-6336... Fax: (314) 781-2714

SERVICE POLICY AND PROCEDURE GUIDE ADDITIONAL WARRANTY EXCLUSIONS

1. Resetting of safety thermostats, circuit breakers, overload protectors, or fuse replacements unless warranted conditions are the cause.
2. All problems due to operation at voltages other than specified on equipment nameplates; conversion to correct voltage must be the customer's responsibility.
3. All problems due to electrical connections not made in accordance with electrical code requirements and wiring diagrams supplied with the equipment.
4. Replacement of items subject to normal wear, to include such items as knobs and light bulbs. Normal maintenance functions including adjustment of thermostats, microswitches, and replacement of fuses and indicating lights are not covered under warranty.
5. All problems due to inadequate water supply, such as fluctuating, or high or low water pressure.
6. All problems due to mineral/calcium deposits, or contamination from chlorides/chlorines. De-liming is considered a preventative maintenance function and is not covered by warranty.
7. Full use, care and maintenance instructions are supplied with each machine. Those miscellaneous adjustments noted are customer responsibility. Proper attention will prolong the life of the machine.
8. Travel mileage is limited to sixty (60) miles from an authorized Service Agency or one of its sub-agencies.
9. All labor shall be performed during normal working hours. Overtime premium shall be charged to the customer.
10. All genuine Bloomfield replacement parts are warranted for ninety (90) days from date of purchase on non-warranted equipment. **Any use of non-genuine Bloomfield parts completely voids any warranty.**
11. Installation, labor and job check-out are not considered warranty.
12. Charges incurred by delays, waiting time or operating restrictions that hinder the service technicians ability to perform services are not covered by warranty. This includes institutional and correctional facilities.

SHIPPING DAMAGE CLAIMS PROCEDURE

NOTE: For your protection, please note that equipment in this shipment was carefully inspected and packaged by skilled personnel before leaving the factory. Upon acceptance of this shipment, the transportation company assumes full responsibility for its safe delivery.

IF SHIPMENT ARRIVES DAMAGED:

1. **VISIBLE LOSS OR DAMAGE:** Be certain that any visible loss or damage is noted on the freight bill or express receipt, and that the note of loss or damage is signed by the delivery person.
2. **FILE CLAIM FOR DAMAGE IMMEDIATELY:** Regardless of the extent of the damage.



3. **CONCEALED LOSS OR DAMAGE:** if damage is unnoticed until the merchandise is unpacked, notify the transportation company or carrier immediately, and file "CONCEALED DAMAGE" claim with them. This must be done within fifteen (15) days from the date the delivery was made to you. Be sure to retain the container for inspection.

Wells Bloomfield cannot assume liability for damage or loss incurred in transit. We will, however, at your request, supply you with the necessary documents to support your claim.

TABLE OF CONTENTS

WARRANTY STATEMENT	xi	Thank You for purchasing this Wells Bloomfield appliance.
SPECIFICATIONS	1	
FEATURES & OPERATING CONTROLS	2	
PRECAUTIONS & GENERAL INFORMATION	3	Proper installation, professional operation and consistent maintenance of this appliance will ensure that it gives you the very best performance and a long, economical service life.
AGENCY LISTING INFORMATION	3	
INSTALLATION INSTRUCTIONS	4	
OPERATION	6	
CLEANING INSTRUCTIONS	7	
TROUBLESHOOTING SUGGESTIONS	8	
SERVICING INSTRUCTIONS	9	This manual contains the information needed to properly install this appliance, and to use, care for and maintain or repair the appliance in a manner which will ensure its optimum performance.
Deliming Instructions	12	
EXPLODED VIEW & PARTS LIST	13	
WIRING DIAGRAMS	16	

SPECIFICATIONS

MODEL	VOLTS 1ø 50/60Hz	WATTS	AMPS 1ø	POWER SUPPLY CORD
1222	120	1800	15	NEMA 5-15P
1222CA 	120	1500	12.8	
1225 	208	4000	19	NEMA 6-30P
1226 	240	4000	16.5	

 Meets Canadian standards

APPLICABILITY

This manual applies to the following Wells Bloomfield products:

1222	2-Gallon Hot Water Dispenser
1222CA	2-Gallon Hot Water Dispenser
1225	5-Gallon Hot Water Dispenser
1226	5-Gallon Hot Water Dispenser

FEATURES AND OPERATING CONTROLS

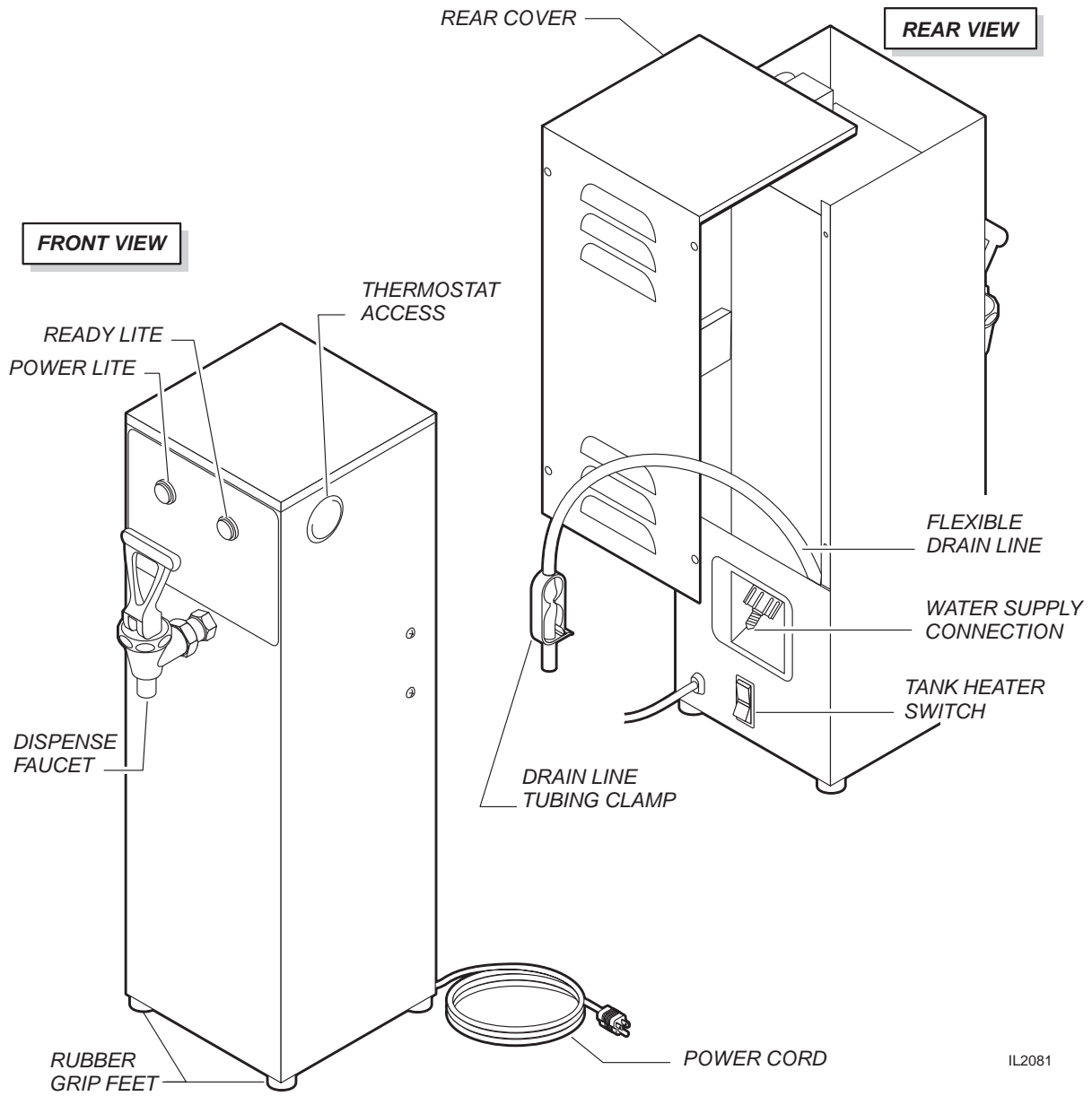

PRECAUTIONS AND GENERAL INFORMATION



WARNING: ELECTRIC SHOCK HAZARD

All servicing requiring access to non-insulated components must be performed by qualified service personnel. Do not open any access panels which require the use of tools. Failure to heed this warning can result in electrical shock.



WARNING: INJURY HAZARD

All installation procedures must be performed by qualified personnel with full knowledge of all applicable electrical and plumbing codes. Failure could result in property damage and personal injury.



WARNING: ELECTRIC SHOCK HAZARD

Hot Water Dispenser must be properly grounded to prevent possible shock hazard. DO NOT assume a plumbing line will provide such a ground. Electrical shock will cause death or serious injury.



WARNING: BURN HAZARD

This appliance dispenses very hot liquid. Serious bodily injury from scalding can occur from contact with dispensed liquids.

This appliance is intended for commercial use only.

This appliance is intended for use to dispense heated water. No other use is recommended or authorized by the manufacturer or its agents.

This appliance is intended for use in commercial establishments, where all operators are familiar with the appliance use, limitations and associated hazards. Operating instructions and warnings must be read and understood by all operators and users.

Except as noted, this piece of equipment is made in the USA and has American sizes on hardware. All metric conversions are approximate and can vary in size.

The following trouble shooting, component views and parts lists are included for general reference, and are intended for use by qualified service personnel.

This manual should be considered a permanent part of this appliance. The manual must remain with the appliance if it is sold or moved to another location.



CAUTION: EQUIPMENT DAMAGE

DO NOT plug in or energize this appliance until all *Installation Instructions* are read and followed. Damage to the dispenser will occur if these instructions are not followed.



CAUTION: BURN HAZARD

Dispensed liquid is VERY HOT and can cause burns.



CAUTION: BURN HAZARD

Exposed surfaces of the appliance may be HOT to the touch and can cause burns.

AGENCY LISTING INFORMATION

This dispenser is  and  listed under file E9253.

This dispenser meets  Standard 4 only when installed, operated and maintained in accordance with the enclosed instructions.



E9253



E9253



STANDARD 4

INSTALLATION

READ THIS CAREFULLY BEFORE STARTING THE INSTALLATION

IMPORTANT:

To enable the installer to make a quality installation and to minimize installation time, the following suggestions and tests should be done before the actual unit installation is started:



CAUTION: EQUIPMENT DAMAGE

DO NOT plug in or energize this appliance until all Installation Instructions are read and followed. Damage to the dispenser will occur if these instructions are not followed.



CAUTION: UNSTABLE EQUIPMENT HAZARD

It is very important for safety and for proper operation that the dispenser is level and stable when standing in its final operating position. Provided adjustable, non-skid legs must be installed at each corner of the unit. Failure to do so will result in movement of the dispenser which can cause personal injury and/or damage to appliance.

NOTE: Water supply inlet line must meet certain minimum criteria to insure successful operation of the dispenser. Bloomfield recommends 1/4" copper tubing for installation of less than 12 feet and 3/8" for more than 12 feet from a 1/2" water supply line.

REFER TO EXPLODED VIEWS PAGE 14 FOR COMPONENT NAMES/NUMBERS.

Unpack the unit. Inspect all components for completeness and condition. Ensure that all packing materials have been removed from the unit.

LEVELING THE UNIT

Two Gallon Dispenser is NOT provided with adjustable legs. Be sure dispenser is placed on a solid level surface with all four feet touching the surface.

Five Gallon Dispenser is provided with adjustable legs. Verify that an adjustable leg is installed at each corner of the brewer. Set Brewer in its operating location. Level the Brewer. A spirit level should be placed on the top of the unit, at the edge, as a guide when making level adjustments. Level the unit from left to right and front to back by turning the adjustable feet. Be sure all four feet touch the counter to prevent tipping.

PLUMBER'S INSTALLATION INSTRUCTIONS

Dispenser should be connected to a **POTABLE WATER, COLD WATER** line. Flush water line before connecting to appliance.

DO NOT use a saddle valve with a self-piercing tap for the water line connection. Such a tap can become restricted by waterline debris. For systems that must use a saddle tap, shut off the main water supply and drill a 3/16" (minimum) tap for the saddle connection, in order to insure an ample water supply. Remember to flush the line prior to installing the saddle.

The dispenser must be installed on a water line with average pressure between 20 PSI and 90 PSI. If your water pressure exceeds 90 PSI at anytime, a pressure regulator must be installed in the water supply line to limit the pressure to not more than 90 PSI in order to avoid damage to lines and solenoid.

A water shut-off valve should be installed on the incoming water line in a convenient location (Use a low restriction type valve, such as a 1/4-turn ball valve, to avoid loss of water flow thru the valve.

INSTALLATION (continued)

NSF requires that the unit be able to be moved for cleaning underneath. A flex line or loops of copper tubing will satisfy this requirement. See Figure 2 below.

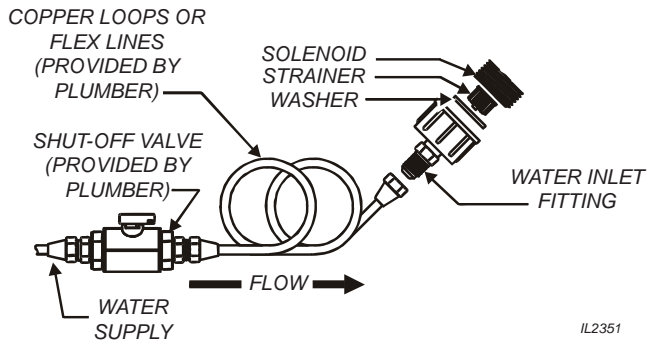

Fig. 2 Water Supply Installation

In some areas, local codes require a backflow preventer (check valve) to be installed on the inlet water line. If a backflow preventer is used, you must install a *water hammer arrester* in the incoming line, between the backflow preventer and the brewer inlet, as far away from the brewer as space will allow. This will relieve the excessive back pressures that can cause faucet leaks and solenoid malfunctions.

ELECTRICIAN'S INSTALLATION INSTRUCTIONS

REFER TO ELECTRICAL SPECIFICATIONS - Page 1
Check the nameplate to determine correct electrical service required for the dispenser to be installed.

IMPORTANT: Before connecting to electricity, make sure dispenser is connected to the water supply.

Model 1222 is equipped with a cord and plug. It requires a 115 - 125 volt 20 amp circuit (50/60 Hz, 2 wire plus ground, with NEMA 5-15R).

Model 1222CA is equipped with a cord and plug. It requires a 115 - 125 volt 15 amp circuit (50/60 Hz, 2 wire plus ground, with NEMA 5-15R).



CAUTION: EQUIPMENT DAMAGE

DO NOT connect Model 1225 to a circuit with voltage higher than 208V. Equipment damage will result.
Such damage is NOT covered by warranty.

Model 1225: is equipped with a cord and plug. It requires a 208V, 30 amp circuit (50/60 Hz, 2 wire plus ground, with NEMA 6-30R).

Model 1226: is equipped with a cord and plug. It requires a 240V, 30 amp circuit (50/60 Hz, 2 wire plus ground, with NEMA 6-30R).

NOTE: This equipment must be installed to comply with applicable federal, state and local plumbing codes and ordinances.



CAUTION: SHOCK HAZARD

Dispenser must be properly grounded to prevent possible shock hazard. DO NOT assume a plumbing line will provide such a ground. Electrical shock will cause death or serious injury.

IMPORTANT:

Supply power must match nameplate for voltage and phase. Connecting to the wrong voltage will damage the appliance or result in decreased performance. Such damage is not covered by warranty.

IMPORTANT: Do not connect dispenser to electrical power until you are ready to fill the tank.

IMPORTANT: The ground prong of the plug is part of a system designed to protect you from electrical shock in the event of internal damage. Never cut off the ground prong nor twist a blade to fit an existing receptacle. Contact a licensed electrician to install the proper circuit and receptacle.

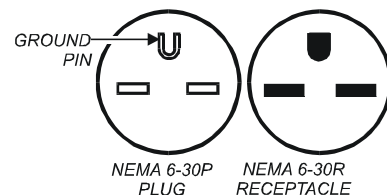
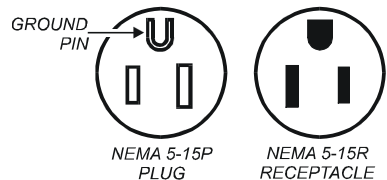

OPERATION

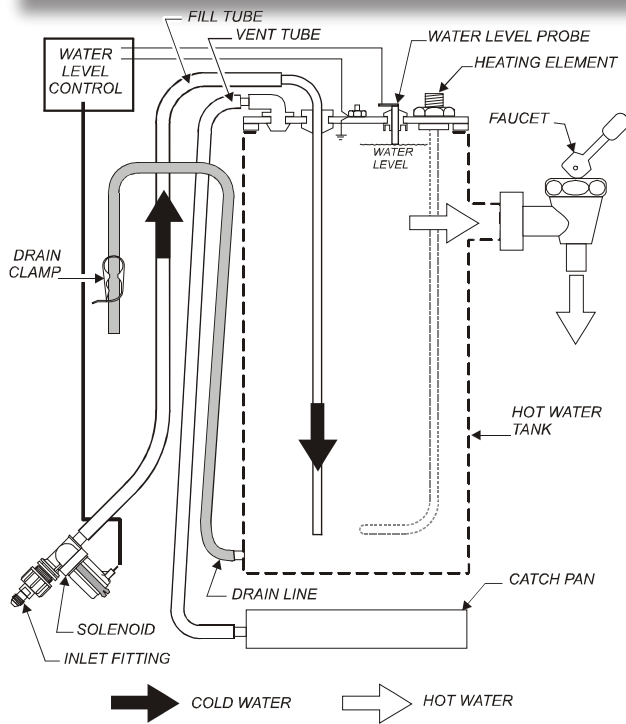

Fig. 3 Dispenser Operation Diagram

WATER HEATER

Water temperature is sensed by thermobulb inserted into the water tank. Temperature is controlled by a mechanical thermostat.

The setpoint temperature is adjustable by turning the thermostat shaft.

Excessive temperature will trip the hi-limit safety switch, disabling the heating element. The hi-limit will automatically reset when the dispenser cools.

WATER LEVEL

Water level is controlled by an electronic controller. The water level probe senses chassis ground through the water. When the water level is below the probe no ground is sensed. The controller opens the fill solenoid until the water level makes contact with the probe.

IMPORTANT:

Be sure tank is filled with water before pressing tank heater switch to **ON**.

A. START-UP

For initial start-up, or if the dispenser has not been used for an extended period of time:

- Be sure the water supply is properly connected and the water supply valve is turned **ON**.
- Be sure the **WATER TANK IS FILLED**.

IMPORTANT: Fill the water tank before energizing tank heater:

1. Be sure **TANK HEATER SWITCH** is "**OFF**", then plug unit into an appropriate receptacle. "**POWER**" light will glow any time unit is connected to electric power.
2. The fill solenoid will open and water tank will begin filling.
3. When the fill solenoid shuts off, open the faucet. Run water until the fill solenoid is energized again, then close the faucet. This will purge all air from the system. When fill solenoid shuts off, tank is filled.
4. Press tank heater switch to "**ON**". Tank heaters will energize. When the "**HOT WATER READY**" light glows, water is ready to use.

A. USE

1. Always use a container suitable for hot water.
2. Hold container under faucet. Pull faucet handle to dispense hot water. Release handle to stop dispensing.

CLEANING INSTRUCTIONS

PROCEDURE: Clean Hot Water Dispenser

PRECAUTIONS: Disconnect dispenser from electric power.
Allow dispenser to cool.

FREQUENCY: Daily

TOOLS: Mild Detergent, Clean Soft Cloth or Sponge
Bristle Brush

1. Disconnect dispenser from electric power.
Allow to cool before cleaning.
2. Wipe exterior of dispenser with a soft clean cloth or sponge moistened with mild detergent and clean water. Rinse by wiping with a soft clean cloth or sponge moistened clean water.
3. Wipe faucet nozzle to remove any mineral deposits. A bristlebrush may be used to remove stubborn mineral build-up.

Procedure is complete



CAUTION: BURN HAZARD

Dispensed water is extremely hot. Hot water will cause serious skin burns.



CAUTION: SHOCK HAZARD

Do not submerge or immerse dispenser in water.

IMPORTANT:

DO NOT use steel wool, sharp objects, or caustic, abrasive or chlorinated cleansers to clean the dispenser's stainless steel surfaces.

TROUBLESHOOTING SUGGESTIONS

SYMPTOM	POSSIBLE CAUSE	SUGGESTED REMEDY
Water won't heat	Dispenser unplugged or circuit breaker tripped	Check power supply cord Check / reset circuit breaker
	Tank heater switch "OFF"	Press switch to "ON"
	Temperature setpoint too low	Adjust thermostat for desired temperature
	Hi-Limit safety switch tripped	Allow to cool hi-limit will self-reset
	Damaged internal component or wiring	Examine wiring & connectors, controller, power board and heating element. Repair/replace as needed
No flow from hot water faucet	Water supply OFF	Turn water supply ON
	Solenoid inlet strainer plugged	Clean strainer
	Water filter (if used) plugged	Replace filter element
	Faucet plugged	Disassemble faucet, clean
Water faucet drips	Debris in faucet seat	Disassemble faucet, clean
	Faucet damaged	Examine faucet, repair or replace as needed

SERVICING INSTRUCTIONS

ACCESS PANELS

REAR PANEL:

Remove rear panel to access hot water tank, thermostat, heating elements, tubing, water level control and plumbing connections.

Rear panel is held by four screws at the back. The flanged top portion fits over the body of the dispenser.

SOLENOID DOOR:

Solenoid door may be removed to aid in solenoid replacement. This access panel is not normally removed.

Solenoid door is held by two screws and a retaining lip.

BUTTON PLUG:

Remove button plug to adjust thermostat temperature setting.



CAUTION: SHOCK HAZARD

Opening access panels on this dispenser may expose uninsulated electrical components. Disconnect dispenser from electrical power before removing any panel.

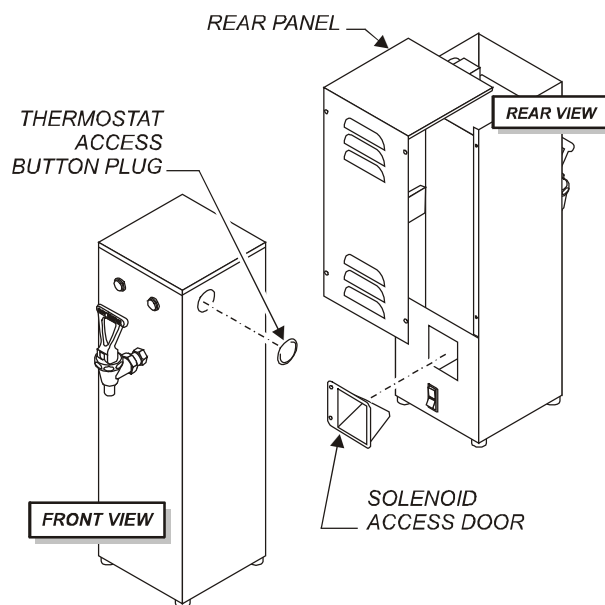
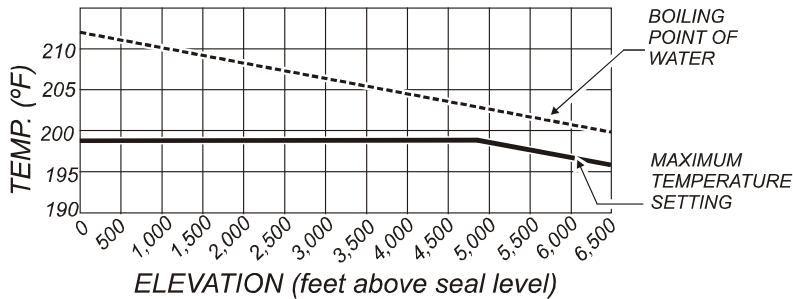

Fig. 3 Access Panels

SERVICING INSTRUCTIONS (continued)

TEMPERATURE ADJUSTMENT

Check temperature at discharge of faucet.
Remove thermostat access button plug to access thermostat.
Turn thermostat shaft clockwise to increase temperature.



REMOVE TANK LID ASSEMBLY

Unplug dispenser or turn circuit breaker *OFF*. Turn *OFF* water supply. Remove rear panel.

Disconnect fill tube and vent tube from tank lid. Disconnect wiring from hi-limit, thermostat and heating element as necessary. Remove eight lid screws. Remove lid assembly by lifting it straight up.

Reassemble in reverse order.

REPLACE THERMOSTAT

Unplug dispenser. Remove back panel.

Loosen and free jam nut from pass-thru fitting securing thermobulb. Lift out probe, jamb nut and gasket. Disconnect wiring from thermostat. Loosen screws holding thermostat to bracket. Remove thermostat.

Reassemble in reverse order.

IMPORTANT:

The thermostat will maintain temperature within $\pm 3^{\circ}\text{F}$. For high altitude locations, thermostat should be adjusted to a maximum temperature equal to the local boiling temperature minus 5° . This will prevent boiling water in the dispenser,

NOTE:

Thermostat is adjustable to a maximum of 199°F .

IMPORTANT:

Water pressure must be between 20 p.s.i and 90 p.s.i. flowing pressure. If water pressure exceeds this value, or if water pressure varies greatly, a pressure regulator must be installed in the water supply line.

IMPORTANT:

Before setting lid assembly into tank, make sure tank lid gasket is properly seated on flange of lid.

SERVICING INSTRUCTIONS (continued)

REPLACE HEATING ELEMENT

Remove tank lid assembly as detailed on page 10.

Remove two hex nuts holding element to cover. Pull element from mounting holes.

Reassemble in reverse order.

REPLACE SOLENOID

Unplug power cord. Turn *OFF* and disconnect water supply from dispenser inlet fitting.

Remove rear panel. Remove two screws holding access door in place. Remove access door and solenoid. Unscrew inlet fitting cap to release solenoid from door. Remove wiring from solenoid.

Transfer fill tube from old solenoid to new solenoid.

Reassemble in reverse order.

REPAIR HOT WATER FAUCET

Unplug power cord. Turn *OFF* water. Unscrew bonnet from faucet, then pull bonnet assembly from faucet body.

Examine the interior of the faucet body and the surface of the seat cup. Clean out any debris in the faucet body, using a stiff bristle brush if necessary.

If required, work the seat cup out of the bonnet and off of the end of the stem. Install a new seat cup, making sure the knob on the stem is fully inserted into the pocket of the seat cup, and the skirt of the seat cup is fully inserted into the bonnet

Reassemble in reverse order.

IMPORTANT:

When replacing heating element, also replace seal gaskets.

NOTE: Any abrasion or roughness on the flat end of the seat cup will require replacing the seat cup:

SERVICING INSTRUCTIONS (continued)



CAUTION: **CHEMICAL BURN** **HAZARD**

Deliming chemicals may be caustic. Wear appropriate protective gloves and goggles during this procedure. Never siphon deliming chemicals or solutions by mouth. This operation should only be performed by qualified and experienced service personnel.

IMPORTANT: DO NOT spill, splash or pour water or deliming solution into or over any internal component other than the inside of the water tank.

IMPORTANT: DO NOT allow any internal components to come into contact with the deliming solution. Take care to keep all internal components dry.

NOTE: Repeat steps 4 thru 5 as required to remove all scale and lime build-up.

NOTE: Normally, silicone hoses do not need to be delimed. Should deliming hoses become necessary, Bloomfield recommends replacing the hoses

PROCEDURE: Delime the Water Tank

PRECAUTIONS: Disconnect dispenser from electric power. Allow dispenser to cool.

FREQUENCY: As required (dispenser slow to heat)

TOOLS: Deliming Solution
Protective Gloves, Goggles & Apron
Mild Detergent, Clean Soft Cloth or Sponge
Bristle Brush, Bottle Brush
Large Sink (or other appropriate work area)

1. Unplug power cord. Turn off the water shut-off valve and disconnect the water supply line from the inlet fitting.
2. Remove the tank lid assembly as detailed on page 10.
3. Using the drain tube, drain all water from water tank. When finished, be sure drain tube clamp is secured.
4. Mix 2 gallons of deliming solution according to the manufacturer's directions. Carefully pour the deliming solution into the water tank. Lower the lid assembly back onto the tank. Allow to sit for 30 minutes, or as directed by the manufacturer.
5. At end of soaking period, remove lid assembly from tank. Thoroughly rinse internal components of lid assembly with clear water. Using a stiff bristle brush, scrub the heating element to remove lime and calcium build-up. Rinse with clean water. Store lid assembly in a safe location.
6. Drain the water tank. Using a stiff bristle brush, scrub the interior of the water tank to remove lime and calcium build-up. Rinse with clean water.
7. Reassemble the tank lid to the water tank. Make sure the gasket is properly in place. Reinstall wiring to heating element and thermostat. Reinstall fill and vent tubes.
8. Reconnect water supply. Plug in power cord.
9. Allow dispenser to fill, then drain. Repeat three times.
10. Press tank heater switch "ON". When ready light glows, dispenser is ready to use.

EXPLODED VIEWS AND PARTS LISTS

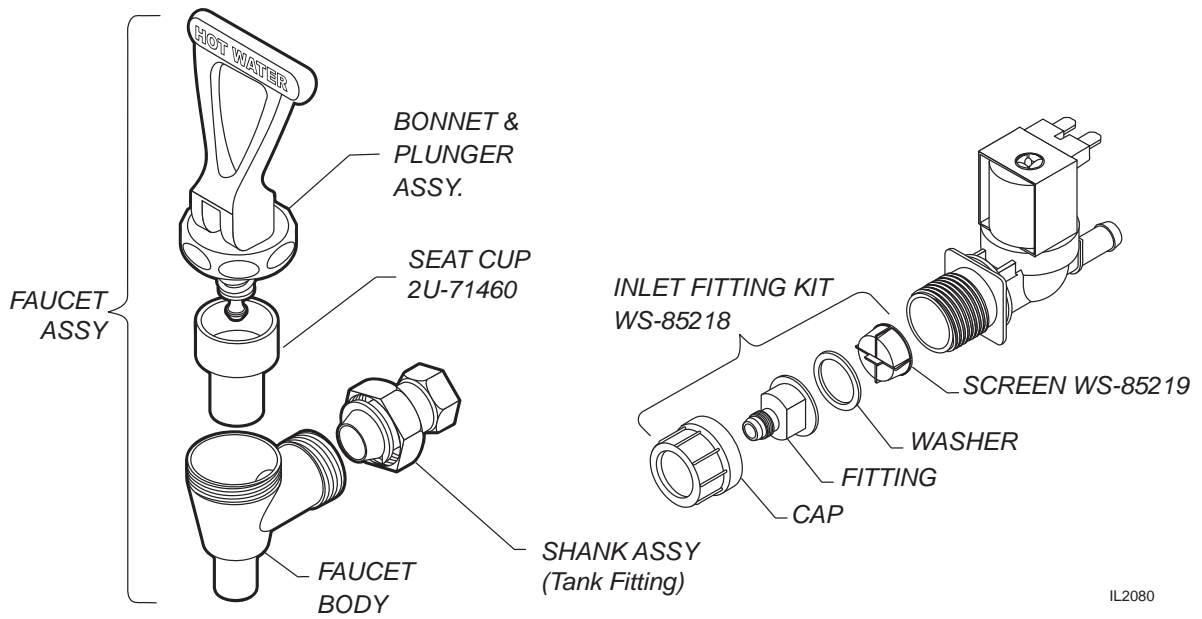

IL2080

SERVICE KITS

FAUCET REPAIR KITS

WS-86597	Faucet & Shank Complete (1222, 1222CA)
2U-71460	Seat Cup (only)
2U-84396	Shank Assy, Faucet
2U-87030	Faucet Assy Brass (1225, 1226)

SOLENOID REPAIR KITS

2E-73612	Solenoid Complete, Single 120V (1222, 1222CA)
2E-75760	Solenoid Complete, Single 240V (1225, 1226)
WS-85218	Inlet Fitting Kit (includes cap, fitting, washer & screen)
WS-85219	Inlet Strainer (only)

EXPLODED VIEW & PARTS LIST

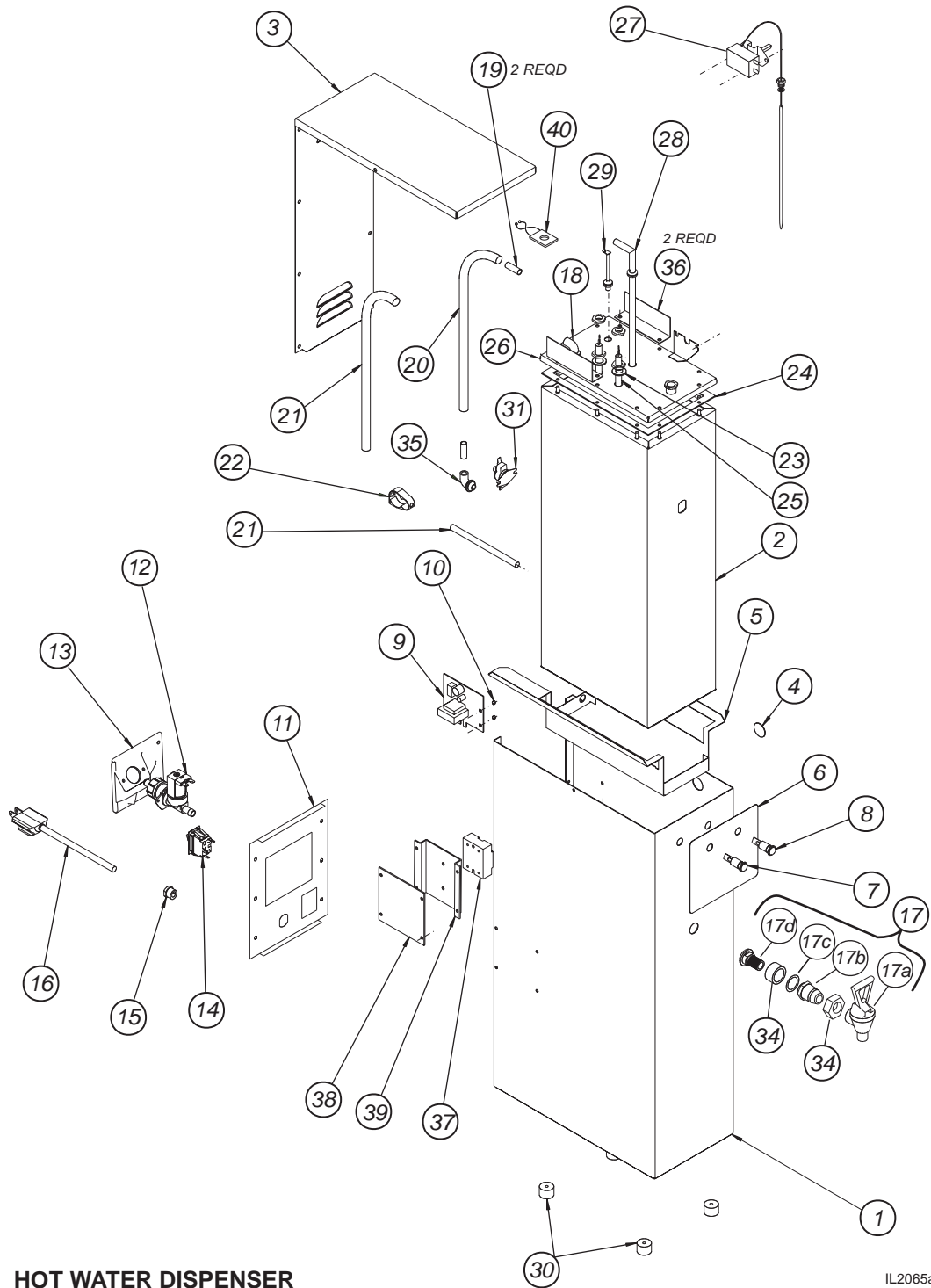

HOT WATER DISPENSER

IL2065a

NOTE: Model 1225/1226 shown. Model 1222/1222CA is similar.

EXPLODED VIEW & PARTS LIST (continued)

ITEM	DESCRIPTION	1222 P/N	1222CA P/N	1225 P/N	1226 P/N
1	WRAP, BODY	C7-76579		C7-76709	
2	TANK ASSY	C7-76578		C7-76710	
3	PANEL, TOP BACK	C7-76512		C7-76713	
4	PLUG, BUTTON 7/8"	2P-70714			
5	SUPPORT, TANK	C7-76521		C7-76712	
6	LABEL, HW DISPENSER	2M-76568			
7	LIGHT, PILOT GREEN	2J-72671		2J-35697	
8	LIGHT, PILOT AMBER	2S-41778		2J-30516	
9	CONTROL, LOW WATER, 120V	2E-46604			
	CONTROL, LOW WATER, 240V			2E-306865	
10	SPACER, NYLON	2A-43201			
11	PANEL, REAR LOWER			C7-76716	
12	SOLENOID, SINGLE 120V	2E-73612			
	SOLENOID SINGLE 240V			2E-75760	
13	DOOR, ACCESS	2Q-75089			
14	SWITCH, ROCKER 250V	2E-305295		2E-302541	
15	STRAIN RELIEF			2K-45788	
16	CORDSET			2E-35259	
17	FAUCET & SHANK ASSY PLASTIC	WS-86597		2U-84396	
				2U-87030 (BRASS)	
17a	FAUCET ASSY	2U-87038			
17b	SHANK ASSY FAUCET		2U-84396		
17c	WASHER FIBER		2C-84489		
17d	FERRULE-VALVE SHANK		2A-84488		
18	ELBOW, OUTLET		2K-70103		
19	TUBE, 3/8 x 3/4" LONG		2A-75609		
20	TUBE, SILICONE .312 DI x 25" LONG		A6-73540		
21	TUBE, BRAIDED .312 ID x 21" LONG		A6-76237		
22	CLAMP, HOSE SHUT OFF		2C-76564		
23	GASKET, HEATING ELEMENT		2I-70152		
24	GASKET, TANK	2I-76514		2I-76776	
25	HEATING ELEMENT, 120V 1800W	2N-76524UL			
	HEATING ELEMENT, 120V 1500W		2N-76571UL		
	HEATING ELEMENT 208V 4000W			2N-76721UL	
	HEATING ELEMENT 240V 4000W				2N-76720UL
26	LID ASSY	C7-76527		C7-76726	
27	THERMOSTAT, TEMPERATURE CONTROL		WS-8512-51		
28	TUBE, TANK FILL		2V-76570		
29	PROBE, LIQUID LEVEL		C7-75746		
30	FOOT, 1/2" HIGH BLACK RUBBER	2A-305148		2A-40564	
31	THERMOSTAT, HI-LIMIT SAFETY	2T-47499		2T-70716	
32	GROMMET, 3/8 ID		2I-72390		
33	SLEEVE, WATER LEVEL PROBE		2A-73532		
34	SPACER, TANK SATELLITE		2A-74316		
35	ELBOW, OUTLET		2K-70130		
36	SPACER, SIDE			C7-76781	
37	RELAY, SOLID STATE			2E-76769	
38	PLATE, HEAT SINK				
39	BRACKET, HEAT SINK				
40	CABLE TIE				
	SEAL, THERMOBULB		2C-70174		

WIRING DIAGRAM

2-GALLON MODELS 1222 and 1222CA

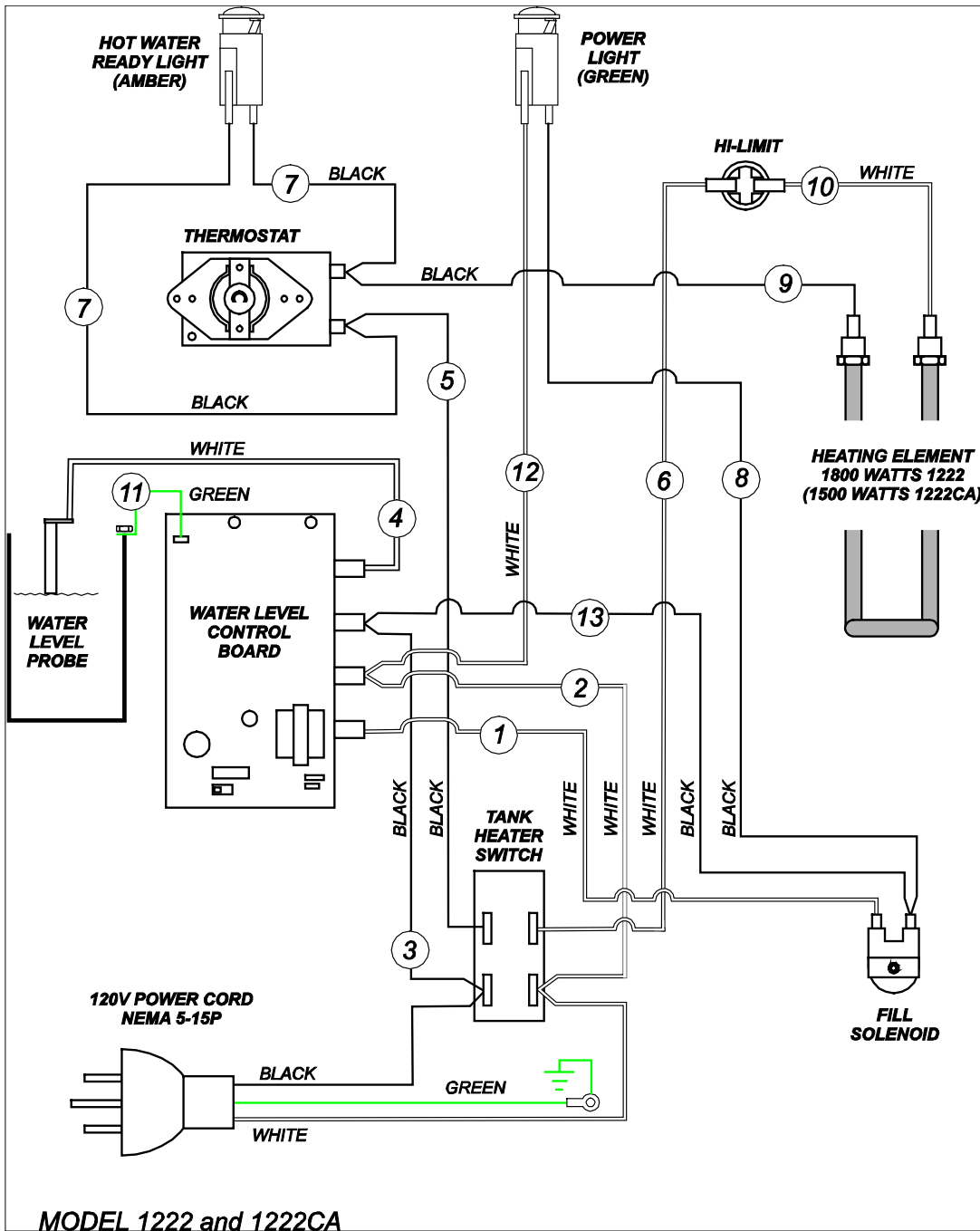

WIRING DIAGRAM (continued)

5-GALLON MODELS 1225 and 1226

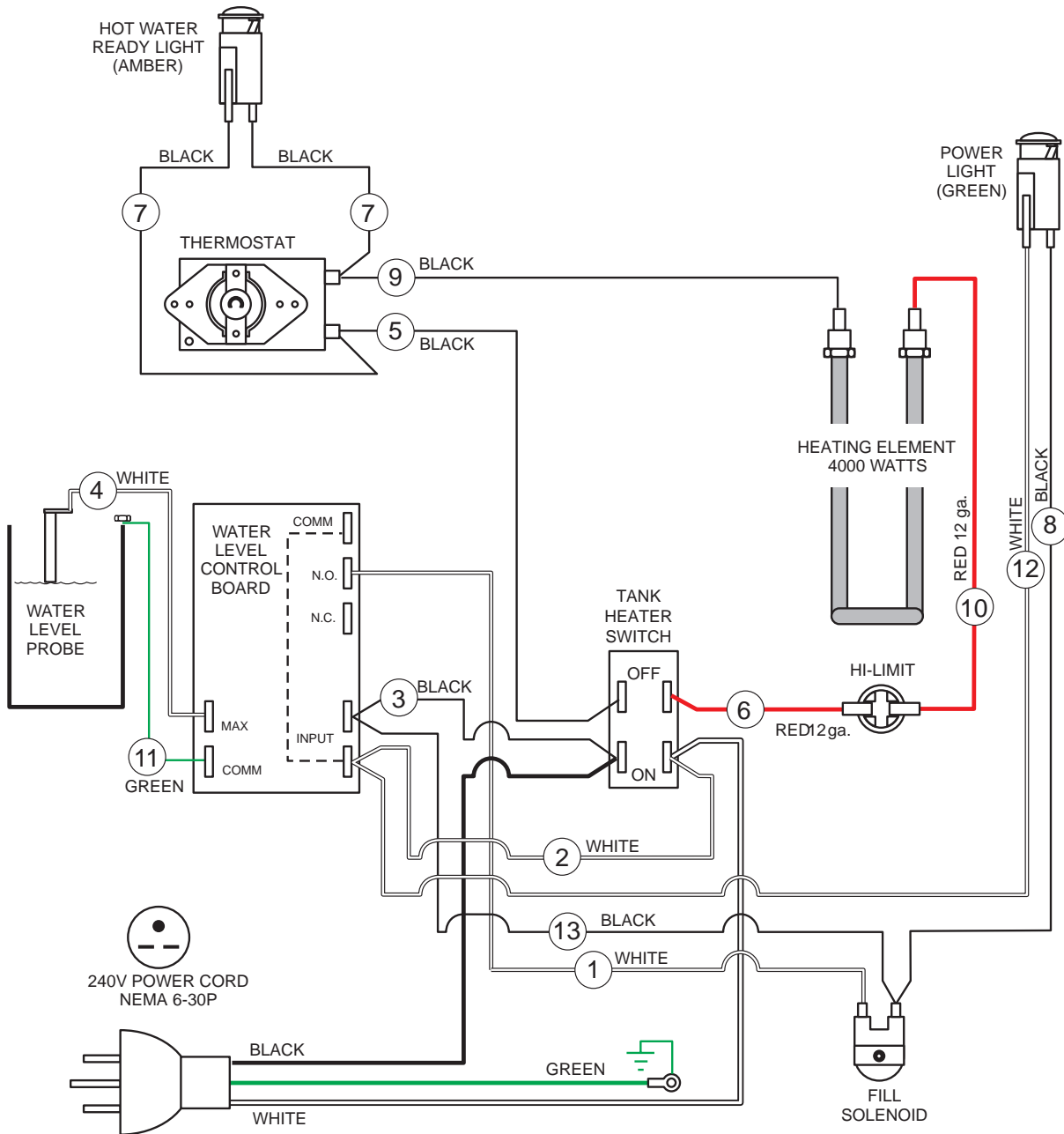

MODEL: 1225 & 1226

MODEL	VOLT	AMPS	Hz
1225	208	19	50/60
1226	240	16.5	50/60

2E-Z13318



Wells Bloomfield proudly supports CFESA
Commercial Food Equipment Service Association

SERVICE TRAINING - QUALITY SERVICE



CUSTOMER SATISFACTION

WELLS BLOOMFIELD

WELLS BLOOMFIELD, LLC

10 Sunnen Drive, St. Louis, MO 63143
telephone: 314-678-6336 fax: 314-781-2714
www.wellsbloomfield.com

Start 4/22/03
Release 5/08/03
Rev. A adds 5-Gallon models
ECN-12571 11/11/03
Rev. B changes exploded view
ECN-12602 12/09/03
Rev. C reverts to original thermostat
ECN-12858 03/29/05
Rev. D adds 14.75" thermowell
ECN-12888 06/16/05
Rev. E changes WirDiag for 1225,6
ECN-13227 02/02/07
Rev. F institutes new format
ECN-13315 07/18/07

Rev. G adds 8512-51 thermostat and
updates phone numbers.
ECN-13387 11/20/07