

Plug Configuration



NEMA 6-15P

WARING COMMERCIAL

240 Volt Toaster

Switchable bread/bagel controls,
four 1½" extra-wide slots;

WCT855

Unit Information

50/60Hz – 11.25 Amps – Watts 2700

Toasts 360 Slices per hr.

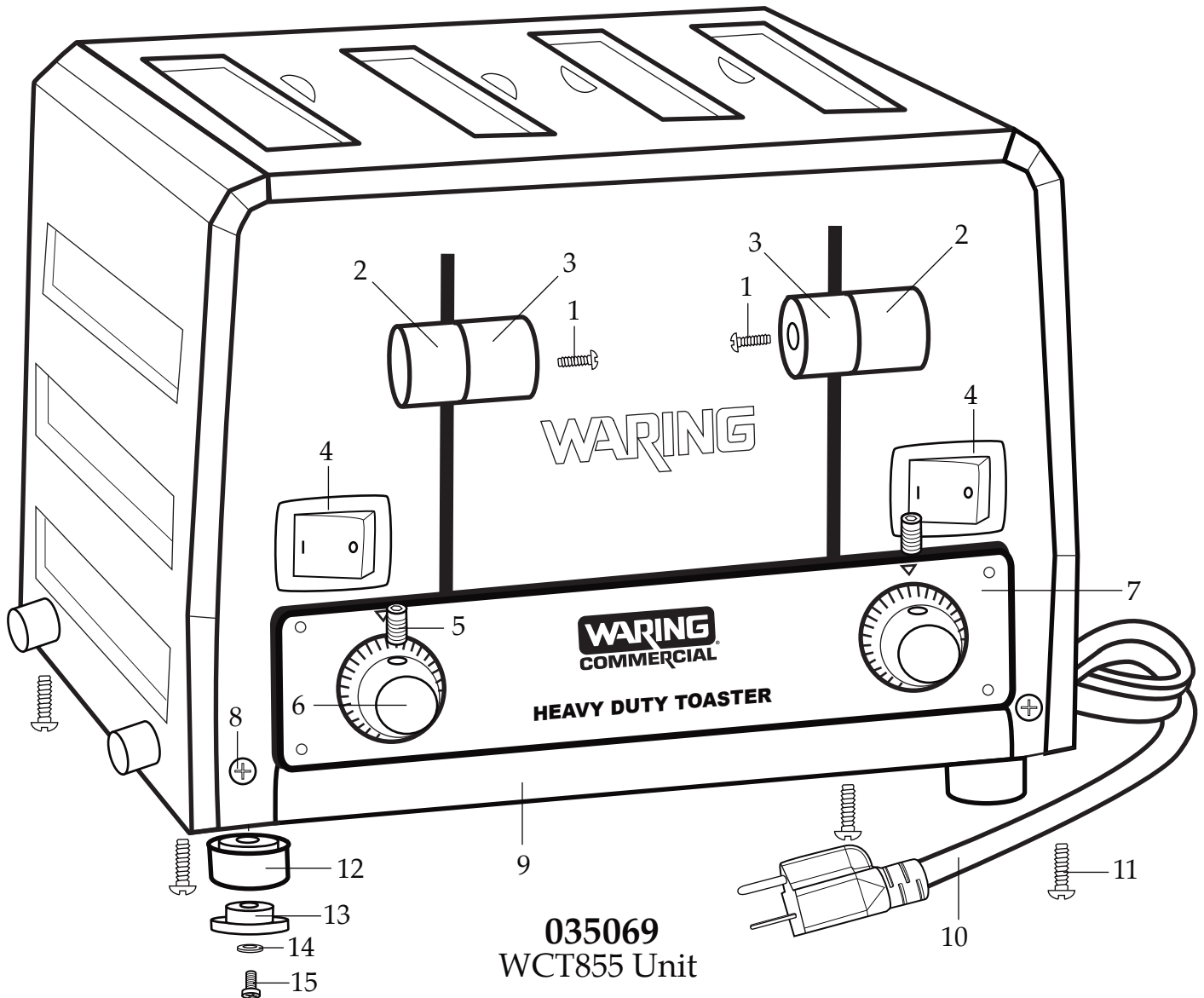

WARING COMMERCIAL

WCT855

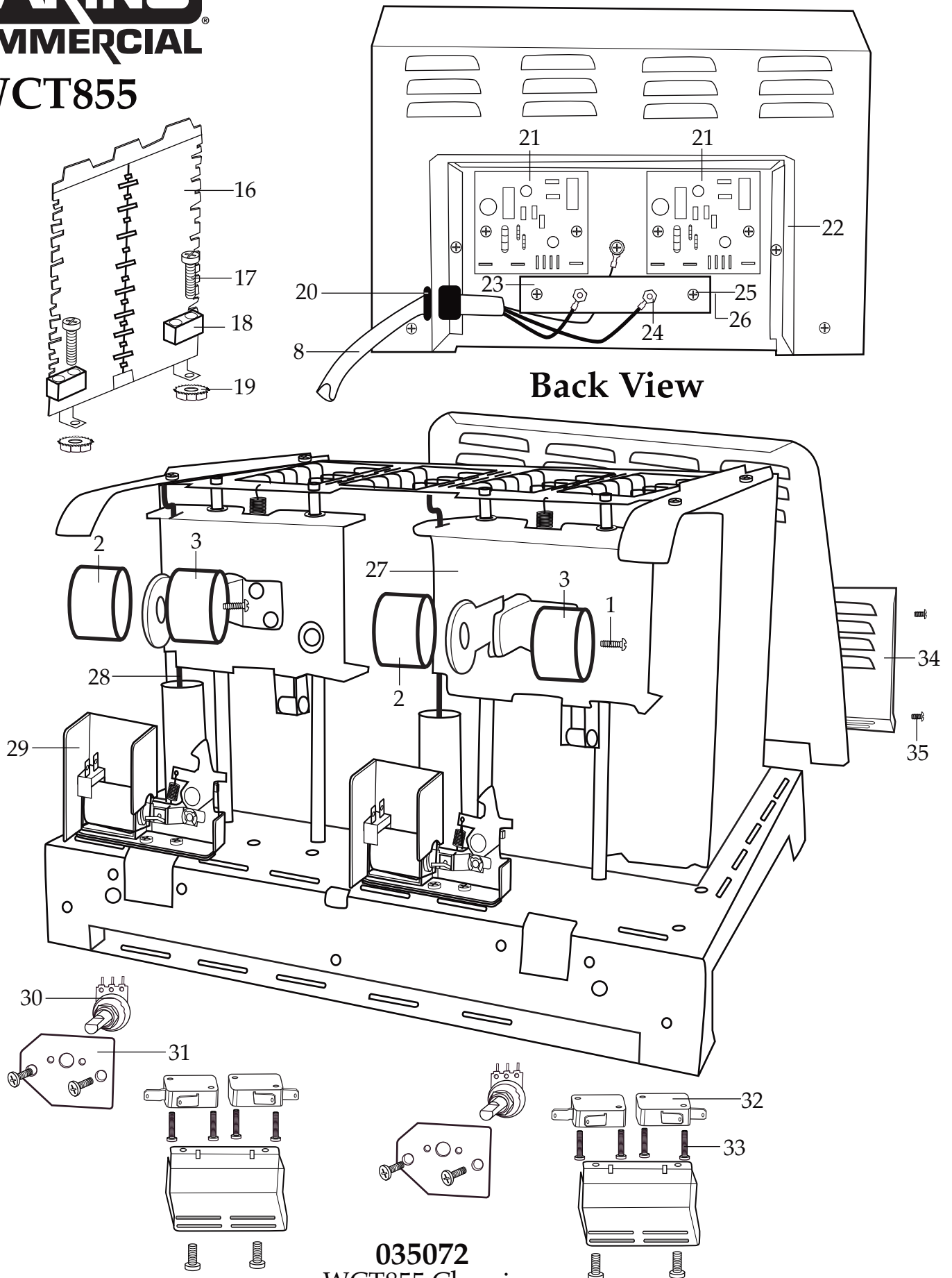

035072
WCT855 Chassis

Illustration #	Part #	Description
1	027172	Screw (2 required)
2	027170	Push Knob (flat outer center 2 required)
3	027171	Push Knob (screw hole in outer center 2 required)
4	033455	Toggle Switch (2 required)
5	027173	Set Screw (2 required)
6	027174	Browning Control Knob (2 required)
7	502939	Front Panel Assembly
8	033460	Screw (2 required)
9	033459	Crumb Tray
10	035073	Cord Set
11	027177	Screw (4 required)
12	027178	Foot (4 required)
13	027179	Rubber Foot (4 required)
14	027180	Washer (4 required)
15	027181	Screw (4 required)
16	035070 035071	Element (16-6102 4 required) Element (16-6192 2 required)
17	027202	Screw (12 required)
18	027203	Ceramic Insulator Bracket (12 required)
19	027205	Hex Nut with Lock Washer (12 required)
20	027224	Strain Relief
21	033454	PC Board (2 required)
22	027218	Power Box Body
23	027216	Power Terminal Board
24	027215	Hex Nut (4 required)
25	027213	Screw (2 required)

Illustration #	Part #	Description
26	027214	Power PCB Holder (2 required)
27	502941	Moving Bracket Assembly (2 required)
28	027191	Damper Cylinder Rod (2 required)
29	027192	Locking Mechanism (2 required)
30	027198	Rheostat (2 required)
31	027199	Insulated Bracket Plate (2 required)
32	033456	Micro Switch (4 required)
33	034769	Screw (2 required for each micro switch)
34	027184	Power Box Cover
35	033460	Screw (4 required)

Note When Changing Elements: Bad elements should be removed one at a time so there is no confusion on what element goes where because some elements are not all the same.

